



MX Series Interface Module Reference



Modified: 2016-10-12

Juniper Networks, Inc.
1133 Innovation Way
Sunnyvale, California 94089
USA
408-745-2000
www.juniper.net

Copyright © 2016, Juniper Networks, Inc. All rights reserved.

Juniper Networks, Junos, Steel-Belted Radius, NetScreen, and ScreenOS are registered trademarks of Juniper Networks, Inc. in the United States and other countries. The Juniper Networks Logo, the Junos logo, and JunosE are trademarks of Juniper Networks, Inc. All other trademarks, service marks, registered trademarks, or registered service marks are the property of their respective owners.

Juniper Networks assumes no responsibility for any inaccuracies in this document. Juniper Networks reserves the right to change, modify, transfer, or otherwise revise this publication without notice.

MX Series Interface Module Reference

Copyright © 2016, Juniper Networks, Inc.
All rights reserved.

The information in this document is current as of the date on the title page.

YEAR 2000 NOTICE

Juniper Networks hardware and software products are Year 2000 compliant. Junos OS has no known time-related limitations through the year 2038. However, the NTP application is known to have some difficulty in the year 2036.

END USER LICENSE AGREEMENT

The Juniper Networks product that is the subject of this technical documentation consists of (or is intended for use with) Juniper Networks software. Use of such software is subject to the terms and conditions of the End User License Agreement ("EULA") posted at <http://www.juniper.net/support/eula.html>. By downloading, installing or using such software, you agree to the terms and conditions of that EULA.

Table of Contents

	About the Documentation	xv
	Documentation and Release Notes	xv
	Supported Platforms	xv
	Documentation Conventions	xv
	Documentation Feedback	xvii
	Requesting Technical Support	xviii
	Self-Help Online Tools and Resources	xviii
	Opening a Case with JTAC	xviii
Part 1	Overview	
Chapter 1	Interface Module Overview	3
	MX Series Interface Module Overview	3
	Line Cards Supported on MX Series Routers	4
	FPCs and PICs	4
	DPCs	4
	Modular Port Concentrator (MPC) and Modular Interface Card (MIC) Interfaces	5
Chapter 2	DPCs Supported on MX Series	7
	MX Series DPC Overview	7
	DPCs Supported on MX240, MX480, and MX960 Routers	7
Chapter 3	MPCs Supported on MX Series	11
	MX Series MPC Overview	11
	MPCs Supported by MX240, MX480, MX960, MX2010, and MX2020 Routers	12
Chapter 4	MICs Supported on MX Series	17
	MX Series MIC Overview	17
	MICs Supported by MX Series Routers	17
	MIC/MPC Compatibility	21
Chapter 5	FPCs and PICs Supported on MX Series	29
	MX Series PIC Overview	29
	High Availability Features	30
	FPCs Supported by MX240, MX480, and MX960 Routers	30
	PICs Supported by MX240, MX480, and MX960 Routers	30

Chapter 6	Network Interface Specifications	33
	Supported Network Interface Standards by Transceiver for ACX Series, M Series, MX Series, and T Series Routers	33
	Cable Specifications for MX Series Transceivers	43
	CFP2-100G-SR10-D3	43
	Gigabit Ethernet 1000BASE Optical Interface Specifications	44
	Gigabit Ethernet 1000BASE-SX Optical Interface Specifications	44
	Gigabit Ethernet 1000BASE-LX Optical Interface Specifications	45
	Gigabit Ethernet 1000BASE-LX10 Optical Interface Specifications	46
	Gigabit Ethernet 1000BASE-EX Optical Interface Specifications	46
	Gigabit Ethernet 1000BASE-LH Optical Interface Specifications	47
	Gigabit Ethernet 1000BASE-T Copper Interface Specifications	47
	Ethernet 10BASE-T Copper Interface Specifications	48
	Fast Ethernet 100BASE-FX Optical Interface Specifications	48
	Fast Ethernet 100BASE-T Copper Interface Specifications	49
	Fast Ethernet and Gigabit Ethernet Bidirectional SFP Optical Interface Specifications	50
	Fast Ethernet 100BASE-BX Bidirectional SFP Optical Interface Specifications	50
	Gigabit Ethernet 1000BASE-BX Bidirectional SFP (U 13/14 and D 14/13) Optical Interface Specifications	51
	Gigabit Ethernet 1000BASE-BX Bidirectional SFP (U 13/15 and D 15/13) Optical Interface Specifications	52
	Gigabit Ethernet 1000BASE-BX Bidirectional SFP (40 U 13/15 and D 15/13) Optical Interface Specifications	52
	Gigabit Ethernet SFP CWDM Optical Interface Specifications	53
	10-Gigabit Ethernet 10GBASE Optical Interface Specifications	54
	10GBASE-LRM Specifications	55
	10GBASE-S Specifications	55
	10GBASE-L Specifications	56
	10GBASE-E Specifications	57
	10GBASE-Z Specifications	57
	10-Gigabit Ethernet DWDM OTN Optical Interface Specifications	59
	10-Gigabit Ethernet DWDM OTN Optical Interface Specifications	60
	10-Gigabit Ethernet DWDM OTN Supported Wavelengths	62
	PC-1XGE-DWDM-OTN Optical Signal-to-Noise Ratio (OSNR) Performance	64
	40-Gigabit Ethernet 40GBASE-R Optical Interface Specifications	64
	40GBASE-SR4 Specifications	65
	40GBASE-LX4 Specifications	65
	40GBASE-LR4 Specifications	66
	40GBASE-ER4 Specifications	67
	100-Gigabit Ethernet 100GBASE-R Optical Interface Specifications	68
	100GBASE-SR10 Specifications	68
	100GBASE-SR4 Specifications	69
	100GBASE-LR4 Specifications	69
	100GBASE-ER4 Specifications	70
	Juniper Networks Specifications for CFP-100GBASE-ZR	71
	100-Gigabit DWDM OTN CFP2-ACO Optical Interface Specifications	72

	SONET/SDH OC3/STM1 Optical Interface Specifications	76
	SONET/SDH OC3/STM1 Specifications	76
	SONET/SDH OC3/STM1 Intermediate Reach (IR-1) Specifications	77
	SONET/SDH OC3/STM1 Long Reach (LR-1) Specifications	77
	SONET/SDH OC12/STM4 Optical Interface Specifications	78
	SONET/SDH OC12/STM4 Short Reach (SR-1) Specifications	78
	SONET/SDH OC12/STM4 Intermediate Reach (IR-1) Specifications	79
	SONET/SDH OC12/STM4 Long Reach (LR-1) Specifications	79
	SONET/SDH OC12/STM4 Long Reach (LR-2) Specifications	80
	SONET/SDH OC48/STM16 Optical Interface Specifications	80
	SONET/SDH OC48/STM16 Short Reach (SR-1) Specifications	81
	SONET/SDH OC48/STM16 Intermediate Reach (IR-1) Specifications	81
	SONET/SDH OC48/STM16 Long Reach (LR-1) Specifications	82
	SONET/SDH OC48/STM16 Long Reach (LR-2) Specifications	82
	SONET/SDH OC192/STM64 Optical Interface Specifications	83
	SONET/SDH OC192/STM64 Very Short Reach (VSR)	83
	SONET/SDH OC192/STM64 Short Reach (SR-1)	84
	SONET/SDH OC192/STM64 Short Reach (SR-2)	84
	SONET/SDH OC192/STM64 Intermediate Reach (IR-2)	85
	SONET/SDH OC192/STM64 Long reach (LR-1)	85
	SONET/SDH OC192/STM64 Long reach (LR-2)	86
Part 2	DPC, MPC, MIC, and PIC Descriptions	
Chapter 7	MX Series DPC Descriptions	89
	Gigabit Ethernet DPC with SFP	90
	Gigabit Ethernet Enhanced DPC with SFP	92
	Gigabit Ethernet Enhanced Ethernet Services DPC with SFP	95
	Gigabit Ethernet Enhanced Queuing Ethernet Services DPC with SFP	98
	Gigabit Ethernet Enhanced Queuing IP Services DPCs with SFP	101
	10-Gigabit Ethernet DPC with XFP	104
	10-Gigabit Ethernet Enhanced DPCs with XFP	106
	10-Gigabit Ethernet Enhanced Ethernet Services DPC with XFP	108
	10-Gigabit Ethernet Enhanced Queuing Ethernet Services DPC with XFP	110
	10-Gigabit Ethernet Enhanced Queuing IP Services DPC with XFP	112
	Multi-Rate Ethernet Enhanced DPC with SFP and XFP	114
	Multi-Rate Ethernet Enhanced Ethernet Services DPC with SFP and XFP	118
	Multi-Rate Ethernet Enhanced Queuing IP Services DPC with SFP and XFP	122
	Multiservices DPC	126
	Tri-Rate Enhanced DPC	128
	Tri-Rate Enhanced Ethernet Services DPC	130
Chapter 8	MX Series MPC Descriptions	133
	16x10GE MPC	134
	Multiservices MPC	136
	MPC1	138
	MPC1E	139
	MPC1 Q	141
	MPC1E Q	143
	MPC2	145

MPC2E	147
MPC2 Q	149
MPC2E Q	151
MPC2 EQ	153
MPC2E EQ	155
MPC2E P	157
MPC2E NG	159
MPC2E NG Q	161
MPC3E	163
MPC3E NG	165
MPC3E NG Q	167
32x10GE MPC4E	169
2x100GE + 8x10GE MPC4E	171
6x40GE + 24x10GE MPC5E	173
6x40GE + 24x10GE MPC5EQ	175
2x100GE + 4x10GE MPC5E	177
2x100GE + 4x10GE MPC5EQ	179
MPC6E	181
MPC7E (Multi-Rate)	182
MPC7E 10G	185
MPC8E	186
MPC9E	188
Chapter 9	
MX Series MIC Descriptions	191
ATM MIC with SFP	192
DS3/E3 MIC	196
Gigabit Ethernet MIC with SFP	199
Port Numbering	201
Gigabit Ethernet MIC with SFP (E)	203
Gigabit Ethernet MIC with SFP (EH)	207
10-Gigabit Ethernet MICs with XFP	209
10-Gigabit Ethernet MIC with SFP+ (10 Ports)	211
10-Gigabit Ethernet MIC with SFP+ (24 Ports)	213
10-Gigabit Ethernet OTN MIC with SFP+ (24 Ports)	214
40-Gigabit Ethernet MIC with QSFP+	216
100-Gigabit Ethernet MIC with CFP	217
100-Gigabit Ethernet MIC with CXP	219
100-Gigabit Ethernet MIC with CXP (4 Ports)	220
100-Gigabit Ethernet MIC with CFP2	221
100-Gigabit DWDM OTN MIC with CFP2-ACO	223
Channelized SONET/SDH OC3/STM1 (Multi-Rate) MICs with SFP	232
Channelized OC3/STM1 (Multi-Rate) Circuit Emulation MIC with SFP	236
Channelized OC3/STM1 (Multi-Rate) Circuit Emulation MIC with SFP (H)	239
Channelized E1/T1 Circuit Emulation MIC	241
Channelized E1/T1 Circuit Emulation MIC (H)	244
Tri-Rate MIC	247
MIC MRATE	251
Multiservices MIC	253
SONET/SDH OC3/STM1 (Multi-Rate) MICs with SFP	254

	SONET/SDH OC192/STM64 MIC with XFP	258
Chapter 10	MX Series PIC Descriptions	261
	Channelized OC12/STM4 Enhanced IQ (IQE) PIC with SFP	262
	Channelized OC48/STM16 Enhanced IQ (IQE) PIC with SFP	267
	SONET/SDH OC3/STM1 (Multi-Rate) PIC with SFP	272
	SONET/SDH OC12/STM4 (Multi-Rate) PIC with SFP	275
	SONET/SDH OC48/STM16 Enhanced IQ (IQE) PIC with SFP	278
	SONET/SDH OC48/STM16 (Multi-Rate) PIC with SFP	282
	SONET/SDH OC48/STM16 PIC with SFP	285
	SONET/SDH OC192c/STM64 PIC	288
	SONET/SDH OC192c/STM64 PIC with XFP	291
Part 3	Protocol and Application Support	
Chapter 11	DPC Protocol and Application Support for MX240, MX480, and MX960	297
	Protocols and Applications Supported by DPCs and Enhanced DPCs (DPC and DPCE-R)	297
	Protocols and Applications Supported by Enhanced Ethernet Services DPCs (DPCE-X)	303
	Protocols and Applications Supported by Enhanced Queuing IP Services DPCs (DPCE-R-Q)	308
	Protocols and Applications Supported by Enhanced Queuing Ethernet Services DPCs (DPCE-X-Q)	312
	Protocols and Applications Supported by the Multiservices DPC (MS-DPC)	317
Chapter 12	MPC Protocol and Application Support for MX240, MX480, MX960, MX2010, and MX2020	319
	Protocols and Applications Supported by MX240, MX480, MX960, MX2010, and MX2020 MPCs	319
	Protocols and Applications Supported by MX240, MX480, MX960, MX2010, and MX2020 MPC1Es	328
	Protocols and Applications Supported by MX240, MX480, MX960, MX2010, and MX2020 MPC2E	334
	Protocols and Applications Supported by the MX240, MX480, MX960, MX2010, and MX2020 MPC3E	343
	Protocols and Applications Supported by the MX240, MX480, MX960, MX2010, and MX2020 MPC4Es	351
	Protocols and Applications Supported by the MX240, MX480, MX960, MX2010, and MX2020 MPC5Es	358
	Protocols and Applications Supported by the MX2010 and MX2020 MPC6E	365
	Protocols and Applications Supported by the MX240, MX480, MX960, MX2010, and MX2020 MPC7Es	372
	Protocols and Applications Supported by MPC8E and MPC9E on the MX2010 and MX2020 Routers	381
	Protocols and Applications Supported by the MS-MIC and MS-MPC	387

List of Figures

Part 1	Overview	
Chapter 6	Network Interface Specifications	33
	Figure 1: MPO Optical Lane Assignments for the CFP2-100G-SR10-D3	44
Part 2	DPC, MPC, MIC, and PIC Descriptions	
Chapter 7	MX Series DPC Descriptions	89
	Figure 2: 20-Port Gigabit Ethernet Enhanced Queuing IP Services DPC with SFP	101
	Figure 3: 40-Port Gigabit Ethernet Enhanced Queuing IP Services DPC with SFP	101
	Figure 4: 2-Port 10-Gigabit Ethernet Enhanced DPC with XFP	106
	Figure 5: 4-Port 10-Gigabit Ethernet Enhanced DPC with XFP	106
Chapter 8	MX Series MPC Descriptions	133
	Figure 6: Multiservices MPC	136
Chapter 9	MX Series MIC Descriptions	191
	Figure 7: 8-Port ATM MIC with SFP	192
	Figure 8: DS3/E3 MIC	196
	Figure 9: 20-Port Gigabit Ethernet MIC with SFP	199
	Figure 10: Port Numbering for the Gigabit Ethernet MIC with SFP (MX960)	201
	Figure 11: Port Numbering for the Gigabit Ethernet MIC with SFP (MX480)	202
	Figure 12: Port Numbering for Gigabit Ethernet MIC with SFP (MX240)	202
	Figure 13: 20-Port Gigabit Ethernet MIC with SFP (E)	203
	Figure 14: Port Numbering for the MIC-3D-20GE-SFP-E (MX960)	205
	Figure 15: Port Numbering for the MIC-3D-20GE-SFP-E (MX480)	206
	Figure 16: Port Numbering for the MIC-3D-20GE-SFP-E (MX240)	206
	Figure 17: 20-Port Gigabit Ethernet MIC with SFP (EH)	207
	Figure 18: 2-Port 10-Gigabit Ethernet MIC with XFP	209
	Figure 19: 4-Port 10-Gigabit Ethernet MIC with XFP	209
	Figure 20: 10-Gigabit Ethernet MIC with SFP+	211
	Figure 21: 40-Gigabit Ethernet MIC with QSFP+	216
	Figure 22: 1-Port 100 Gigabit Ethernet MIC with CFP	217
	Figure 23: 100-Gigabit Ethernet MIC with CXP	219
	Figure 24: 4-Port Channelized SONET/SDH OC3/STM1 (Multi-Rate) MIC with SFP	232
	Figure 25: 8-Port Channelized SONET/SDH OC3/STM1 (Multi-Rate) MIC with SFP	232
	Figure 26: Channelized OC3/STM1 (Multi-Rate) Circuit Emulation MIC with SFP	236

Figure 27: Channelized OC3/STM1 (Multi-Rate) Circuit Emulation MIC with SFP (H)	239
Figure 28: Channelized E1/T1 Circuit Emulation MIC	241
Figure 29: Channelized E1/T1 Circuit Emulation MIC (H)	244
Figure 30: 40-Port Tri-Rate MIC	247
Figure 31: Port Numbering for the Tri-Rate MIC (MX960)	249
Figure 32: Port Numbering for the Tri-Rate MIC (MX480)	250
Figure 33: Port Numbering for the Tri-Rate MIC (MX240)	250
Figure 34: 12-Port Multi-Rate MIC with QSFP+	251
Figure 35: MS-MIC-16G	253
Figure 36: 4-Port SONET/SDH OC3/STM1 (Multi-Rate) MIC with SFP	254
Figure 37: 8-Port SONET/SDH OC3/STM1 (Multi-Rate) MIC with SFP	254
Figure 38: SONET/SDH OC192/STM64 MIC with XFP	258

List of Tables

	About the Documentation	xv
	Table 1: Notice Icons	xvi
	Table 2: Text and Syntax Conventions	xvi
Part 1	Overview	
Chapter 2	DPCs Supported on MX Series	7
	Table 3: DPCs Supported in MX240, MX480, and MX960 Routers	8
Chapter 3	MPCs Supported on MX Series	11
	Table 4: MPCs Supported by MX240, MX480, MX960, MX2010, and MX2020 Routers	12
Chapter 4	MICs Supported on MX Series	17
	Table 5: MICs Supported by MX240, MX480, MX960, MX2010, and MX2020 Routers	18
	Table 6: MICs Supported by MX5, MX10, MX40, MX80, and MX104 Routers	20
	Table 7: MIC/MPC1 Compatibility	21
	Table 8: MIC/MPC2 Compatibility	23
	Table 9: MIC/MPC3 Compatibility	25
	Table 10: MIC/MPC6 Compatibility	27
	Table 11: MIC/MPC8 Compatibility	27
	Table 12: MIC/MPC9 Compatibility	27
Chapter 5	FPCs and PICs Supported on MX Series	29
	Table 13: FPCs Supported by MX Series Routers	30
	Table 14: PICs Supported by MX240, MX480, and MX960 Routers	31
Chapter 6	Network Interface Specifications	33
	Table 15: Supported Ethernet Standards	34
	Table 16: Supported SONET Standards	41
	Table 17: Gigabit Ethernet 1000BASE-SX Optical Interface Specifications	45
	Table 18: Gigabit Ethernet 1000BASE-LX Optical Interface Specifications	45
	Table 19: Gigabit Ethernet 1000BASE-LX10 Optical Interface Specifications	46
	Table 20: Gigabit Ethernet 1000BASE-EX Optical Interface Specifications	46
	Table 21: Gigabit Ethernet 1000BASE-LH Optical Interface Specifications	47
	Table 22: 1000BASE-T Copper Interface Specifications	47
	Table 23: 10BASE-T Copper Interface Specifications	48
	Table 24: Fast Ethernet 100BASE-FX Optical Interface Specifications	48
	Table 25: Ethernet 100BASE-T Copper Interface Specifications	49
	Table 26: Fast Ethernet 100BASE-BX Bidirectional SFP Optical Interface Specifications	50

Table 27: Gigabit Ethernet 1000BASE-BX Bidirectional SFP (U13/14 and D14/13) Optical Interface Specifications	51
Table 28: Gigabit Ethernet 1000BASE-BX Bidirectional SFP (U13/15 and D15/13) Optical Interface Specifications	52
Table 29: Gigabit Ethernet 1000BASE-BX Bidirectional SFP (40 U13/15 and D15/13) Optical Interface Specifications	52
Table 30: Gigabit Ethernet SFP CWDM Optical Interface Specifications	54
Table 31: 10GBASE-LRM Optical Interface Specifications	55
Table 32: 10GBASE-S (10GBASE-SR and 10GBASE-SW) Optical Interface Specifications	56
Table 33: 10GBASE-L (10GBASE-LR and 10GBASE-LW) Optical Interface Specifications	56
Table 34: 10GBASE-E (10GBASE-ER and 10GBASE-EW) Optical Interface Specifications	57
Table 35: 10GBASE-Z (10GBASE-ZR and 10GBASE-ZW) Optical Interface Specifications	58
Table 36: 10-Gigabit Ethernet DWDM OTN Optical Interface Specifications	60
Table 37: 10-Gigabit Ethernet DWDM OTN Supported Wavelengths	63
Table 38: PC-1XGE-DWDM-OTN Optical Signal-to-Noise Ratio (OSNR) Performance	64
Table 39: 40GBASE-SR4 Optical Interface Specifications	65
Table 40: 40GBASE-LX4 Optical Interface Specifications	65
Table 41: 40GBASE-LR4 Optical Interface Specifications	67
Table 42: 40GBASE-ER4 Optical Interface Specifications	67
Table 43: 100GBASE-SR10 Optical Interface Specifications	68
Table 44: 100GBASE-SR4 Optical Interface Specifications	69
Table 45: 100GBASE-LR4 Optical Interface Specifications	69
Table 46: 100GBASE-ER4 Optical Interface Specifications	70
Table 47: Juniper Networks Optical Interface Specifications for CFP-100GBASE-ZR	71
Table 48: 100-Gigabit DWDM OTN CFP2-ACO Optical Interface Specifications	72
Table 49: 100-Gigabit DWDM OTN CFP2-ACO Supported Wavelengths	74
Table 50: SONET/SDH OC3/STM1 Multimode Optical Interface Specifications	77
Table 51: SONET/SDH OC3/STM1 Intermediate Reach Optical Interface Specifications	77
Table 52: SONET/SDH OC3/STM1 Long Reach -1 Optical Interface Specifications	78
Table 53: SONET/SDH OC12/STM4 Short Reach (SR-1) Optical Interface Specifications	79
Table 54: SONET/SDH OC12/STM4 Intermediate Reach (IR-1) Optical Interface Specifications	79
Table 55: SONET/SDH OC12/STM4 Long Reach (LR-1) Optical Interface Specifications	80
Table 56: SONET/SDH OC12/STM4 Long Reach (LR-2) Optical Interface Specifications	80
Table 57: SONET/SDH OC48/STM16 Short Reach (SR-1) Optical Interface Specifications	81

	Table 58: SONET/SDH OC48/STM16 Intermediate Reach (IR-1) Optical Interface Specifications	81
	Table 59: SONET/SDH OC48/STM16 Long Reach (LR-1) Optical Interface Specifications	82
	Table 60: SONET/SDH OC48/STM16 Long Reach (LR-2) Optical Interface Specifications	82
	Table 61: SONET/SDH OC192/STM64 Very Short Reach (VSR1) Optical Interface Specifications	83
	Table 62: SONET/SDH OC192/STM64 Short Reach (SR-1) Optical Interface Specifications	84
	Table 63: SONET/SDH OC192/STM64 Short Reach (SR-2) Optical Interface Specifications	84
	Table 64: SONET/SDH OC192/STM64 Intermediate Reach (IR-2) Optical Interface Specifications	85
	Table 65: SONET/SDH OC192/STM64 Long Reach (LR-1) Optical Interface Specifications	86
	Table 66: SONET/SDH OC192/STM64 Long Reach (LR-2) Optical Interface Specifications	86
Part 2	DPC, MPC, MIC, and PIC Descriptions	
Chapter 9	MX Series MIC Descriptions	191
	Table 67: OTN Alarms and Defects	230
Part 3	Protocol and Application Support	
Chapter 11	DPC Protocol and Application Support for MX240, MX480, and MX960	297
	Table 68: Protocols and Applications Supported by the DPCs and Enhanced DPCs (DPC and DPCE-R)	297
	Table 69: Protocols and Applications Supported by the Enhanced Ethernet Services DPCs (DPCE-X)	304
	Table 70: Protocols and Applications Supported by the Enhanced Queuing IP Services DPCs (DPCE-R-Q)	308
	Table 71: Protocols and Applications Supported by the Enhanced Queuing Ethernet Services DPCs (DPCE-X-Q)	313
	Table 72: Protocols and Applications Supported by the Multiservices DPC (MS-DPC)	317
Chapter 12	MPC Protocol and Application Support for MX240, MX480, MX960, MX2010, and MX2020	319
	Table 73: Protocols and Applications Supported by the MX240, MX480, MX960, MX2010, and MX2020 MPCs	320
	Table 74: Protocols and Applications Supported by the MX240, MX480, MX960, MX2010, and MX2020 Enhanced MPCs (MPC1Es)	328
	Table 75: Protocols and Applications Supported by the MX240, MX480, MX960, MX2010, and MX2020 MPC2E	334
	Table 76: Protocols and Applications Supported by the MX240, MX480, MX960, MX2010, and MX2020 MPC3E	343
	Table 77: Protocols and Applications Supported by the MX Series MPC4E	352

Table 78: Protocols and Applications Supported by the MX240, MX480, MX960, MX2010, and MX2020 MPC5E	358
Table 79: Protocols and Applications Supported by the MX2010 and MX2020 MPC6E	365
Table 80: Protocols and Applications Supported by MPC7Es in the MX240, MX480, MX960, MX2010, and MX2020 Routers	372
Table 81: Protocols and Applications Supported by MPC8E and MPC9E on the MX2010 and MX2020 Routers	381
Table 82: Protocols and Applications Supported by the MS-MIC and MS-MPC	388

About the Documentation

- Documentation and Release Notes on page xv
- Supported Platforms on page xv
- Documentation Conventions on page xv
- Documentation Feedback on page xvii
- Requesting Technical Support on page xviii

Documentation and Release Notes

To obtain the most current version of all Juniper Networks[®] technical documentation, see the product documentation page on the Juniper Networks website at <http://www.juniper.net/techpubs/>.

If the information in the latest release notes differs from the information in the documentation, follow the product Release Notes.

Juniper Networks Books publishes books by Juniper Networks engineers and subject matter experts. These books go beyond the technical documentation to explore the nuances of network architecture, deployment, and administration. The current list can be viewed at <http://www.juniper.net/books>.

Supported Platforms

For the features described in this document, the following platforms are supported:

- MX Series

Documentation Conventions

Table 1 on page xvi defines notice icons used in this guide.

Table 1: Notice Icons







Icon	Meaning	Description
	Informational note	Indicates important features or instructions.
	Caution	Indicates a situation that might result in loss of data or hardware damage.
	Warning	Alerts you to the risk of personal injury or death.
	Laser warning	Alerts you to the risk of personal injury from a laser.
	Tip	Indicates helpful information.
	Best practice	Alerts you to a recommended use or implementation.

Table 2 on page xvi defines the text and syntax conventions used in this guide.

Table 2: Text and Syntax Conventions

Convention	Description	Examples
Bold text like this	Represents text that you type.	To enter configuration mode, type the configure command: user@host> configure
Fixed-width text like this	Represents output that appears on the terminal screen.	user@host> show chassis alarms No alarms currently active
<i>Italic text like this</i>	<ul style="list-style-type: none"> Introduces or emphasizes important new terms. Identifies guide names. Identifies RFC and Internet draft titles. 	<ul style="list-style-type: none"> A policy <i>term</i> is a named structure that defines match conditions and actions. <i>Junos OS CLI User Guide</i> RFC 1997, <i>BGP Communities Attribute</i>
<i>Italic text like this</i>	Represents variables (options for which you substitute a value) in commands or configuration statements.	Configure the machine's domain name: [edit] root@# set system domain-name <i>domain-name</i>

Table 2: Text and Syntax Conventions (*continued*)

Convention	Description	Examples
Text like this	Represents names of configuration statements, commands, files, and directories; configuration hierarchy levels; or labels on routing platform components.	<ul style="list-style-type: none"> To configure a stub area, include the stub statement at the [edit protocols ospf area area-id] hierarchy level. The console port is labeled CONSOLE.
< > (angle brackets)	Encloses optional keywords or variables.	stub <default-metric <i>metric</i> >;
(pipe symbol)	Indicates a choice between the mutually exclusive keywords or variables on either side of the symbol. The set of choices is often enclosed in parentheses for clarity.	broadcast multicast (string1 string2 string3)
# (pound sign)	Indicates a comment specified on the same line as the configuration statement to which it applies.	rsvp { # Required for dynamic MPLS only
[] (square brackets)	Encloses a variable for which you can substitute one or more values.	community name members [community-ids]
Indentation and braces ({ })	Identifies a level in the configuration hierarchy.	[edit] routing-options { static { route default { nexthop <i>address</i> ; retain; } } }
;(semicolon)	Identifies a leaf statement at a configuration hierarchy level.	
GUI Conventions		
Bold text like this	Represents graphical user interface (GUI) items you click or select.	<ul style="list-style-type: none"> In the Logical Interfaces box, select All Interfaces. To cancel the configuration, click Cancel.
> (bold right angle bracket)	Separates levels in a hierarchy of menu selections.	In the configuration editor hierarchy, select Protocols>Ospf .

Documentation Feedback

We encourage you to provide feedback, comments, and suggestions so that we can improve the documentation. You can provide feedback by using either of the following methods:

- Online feedback rating system—On any page of the Juniper Networks TechLibrary site at <http://www.juniper.net/techpubs/index.html>, simply click the stars to rate the content, and use the pop-up form to provide us with information about your experience. Alternately, you can use the online feedback form at <http://www.juniper.net/techpubs/feedback/>.

- E-mail—Send your comments to techpubs-comments@juniper.net. Include the document or topic name, URL or page number, and software version (if applicable).

Requesting Technical Support

Technical product support is available through the Juniper Networks Technical Assistance Center (JTAC). If you are a customer with an active J-Care or Partner Support Service support contract, or are covered under warranty, and need post-sales technical support, you can access our tools and resources online or open a case with JTAC.

- JTAC policies—For a complete understanding of our JTAC procedures and policies, review the *JTAC User Guide* located at <http://www.juniper.net/us/en/local/pdf/resource-guides/7100059-en.pdf>.
- Product warranties—For product warranty information, visit <http://www.juniper.net/support/warranty/>.
- JTAC hours of operation—The JTAC centers have resources available 24 hours a day, 7 days a week, 365 days a year.

Self-Help Online Tools and Resources

For quick and easy problem resolution, Juniper Networks has designed an online self-service portal called the Customer Support Center (CSC) that provides you with the following features:

- Find CSC offerings: <http://www.juniper.net/customers/support/>
- Search for known bugs: <http://www2.juniper.net/kb/>
- Find product documentation: <http://www.juniper.net/techpubs/>
- Find solutions and answer questions using our Knowledge Base: <http://kb.juniper.net/>
- Download the latest versions of software and review release notes: <http://www.juniper.net/customers/csc/software/>
- Search technical bulletins for relevant hardware and software notifications: <http://kb.juniper.net/InfoCenter/>
- Join and participate in the Juniper Networks Community Forum: <http://www.juniper.net/company/communities/>
- Open a case online in the CSC Case Management tool: <http://www.juniper.net/cm/>

To verify service entitlement by product serial number, use our Serial Number Entitlement (SNE) Tool: <https://tools.juniper.net/SerialNumberEntitlementSearch/>

Opening a Case with JTAC

You can open a case with JTAC on the Web or by telephone.

- Use the Case Management tool in the CSC at <http://www.juniper.net/cm/>.
- Call 1-888-314-JTAC (1-888-314-5822 toll-free in the USA, Canada, and Mexico).

For international or direct-dial options in countries without toll-free numbers, see <http://www.juniper.net/support/requesting-support.html>.

PART 1

Overview

- [Interface Module Overview on page 3](#)
- [DPCs Supported on MX Series on page 7](#)
- [MPCs Supported on MX Series on page 11](#)
- [MICs Supported on MX Series on page 17](#)
- [FPCs and PICs Supported on MX Series on page 29](#)
- [Network Interface Specifications on page 33](#)

CHAPTER 1

Interface Module Overview

- [MX Series Interface Module Overview on page 3](#)
- [Line Cards Supported on MX Series Routers on page 4](#)

MX Series Interface Module Overview

The MX Series 3D Universal Edge Routers support different types of interface modules (which are also known as line cards), including:

- Dense Port Concentrators (DPCs)—A DPC provides multiple physical interfaces and Packet Forwarding Engines on a single board that installs into a slot within the MX240, MX480, and MX960 routers. See the following topics for more information about DPCs:
 - [MX Series DPC Overview on page 7](#)
 - [DPCs Supported on MX240, MX480, and MX960 Routers on page 7](#)
- Modular Interface Cards (MICs), which install into Modular Port Concentrators (MPCs)—MICs provide physical interfaces for the router, and install into the MPCs, which provide packet forwarding services. MPCs are inserted into a slot in an MX240, MX480, MX960, MX2010, or MX2020 router. On MX5, MX10, MX40, MX80, and MX104 routers, MICs install directly into the router chassis. There are also fixed-configuration MPCs, with built-in network ports or services functionality, which do not accept MICs. See the following topics for more information about MICs and MPCs:
 - [“MX Series MIC Overview” on page 17 and MX Series MPC Overview on page 11](#)
 - [“MICs Supported by MX Series Routers” on page 17 and MPCs Supported by MX240, MX480, MX960, MX2010, and MX2020 Routers on page 12](#)
 - [MIC/MPC Compatibility on page 21](#)
- Physical Interface Cards (PICs), which install into Flexible PIC Concentrators (FPCs)—PICs and FPCs function similarly to MICs and MPCs. PICs provide physical interfaces for the router, and install into the FPCs, which provide packet forwarding services. FPCs are installed into a slot in an MX240, MX480, or MX960 router. See the following topics for more information about PICs and FPCs:
 - [MX Series PIC Overview on page 29](#)
 - [“PICs Supported by MX240, MX480, and MX960 Routers” on page 30 and FPCs Supported by MX240, MX480, and MX960 Routers on page 30](#)

- Related Documentation**
- [Supported Network Interface Standards by Transceiver for ACX Series, M Series, MX Series, and T Series Routers on page 33](#)

Line Cards Supported on MX Series Routers

Juniper Networks MX Series 3D Universal Edge Routers process incoming and outgoing packets on several different types of line cards, including Dense Port Concentrators (DPCs), Flexible Port Concentrators (FPCs) with associated Physical Interface Cards (PICs), Trio Modular Port Concentrators (MPCs) with associated Modular Interface Cards (MICs). FPCs are populated with PICs for various interface types. DPCs and MPCs combine the functions of FPCs and the PICs, and with associated physical interfaces support a variety of interface types. The configuration syntax for each type of line card is the same: ***type-fpc/pic/port***.

- [FPCs and PICs on page 4](#)
- [DPCs on page 4](#)
- [Modular Port Concentrator \(MPC\) and Modular Interface Card \(MIC\) Interfaces on page 5](#)

FPCs and PICs

An FPC occupies two slots when installed in an MX Series router. The maximum number of supported FPCs varies per router:

- MX960 router—6 FPCs
- MX480 router—3 FPCs
- MX240 router—1 FPC

PICs provide the physical connection to various network media types. The PICs are inserted into a slot in a router. You can install PICs of different media types on the same router as long as the router supports those PICs.

MX Series 3D Universal Edge Routers support 2 PICs per Flexible PIC Concentrator (FPC). The maximum number of supported PICs varies per router:

- MX960 router—12 PICs
- MX480 router—6 PICs
- MX240 router—2 PICs

DPCs

A DPC provides multiple physical interfaces and Packet Forwarding Engines on a single board that installs into a slot within the MX Series 3D Universal Edge Routers. The maximum number of supported DPCs varies per router:

- MX960 router—12 DPC slots
- MX480 router—6 DPC slots

- MX240 router—3 DPC slots



NOTE: In the Junos OS CLI, you use the FPC syntax to configure or display information about DPCs, and you use the PIC syntax to configure or display information about Packet Forwarding Engines on the DPCs.

In addition to Layer 3 routing capabilities, the DPCs also have many Layer 2 functions that allow MX Series routers to be used for many virtual LAN (VLAN) and other Layer 2 network applications.

Modular Port Concentrator (MPC) and Modular Interface Card (MIC) Interfaces

A Modular Port Concentrator supports two Modular Interface Card (MIC) interfaces. The maximum number of supported MPCs varies per router:

- MX960 router—12 MPC slots
- MX480 router—6 MPC slots
- MX240 router—3 MPC slots
- MX80 router—One fixed 10-Gigabit Ethernet MIC with four ports for uplink connections.



NOTE: The MX80 router is available as a modular (MX80) or fixed (MX80-48T) chassis. Both chassis have a fixed Modular Interface Card (MIC) that has 3 10-Gigabit Ethernet ports. The fixed MX80 router has an additional 48 10/100/1000Base-T RJ45 ports. The modular chassis has two dedicated slots for MICs.

Related Documentation

- *MX Series Router Architecture*
- *MX Series Router Packet Forwarding and Data Flow*
- *Ethernet Frame Counts and Statistics on MX Series Routers*

CHAPTER 2

DPCs Supported on MX Series

- [MX Series DPC Overview on page 7](#)
- [DPCs Supported on MX240, MX480, and MX960 Routers on page 7](#)

MX Series DPC Overview

A DPC provides multiple physical interfaces and Packet Forwarding Engines on a single board that installs into a slot within the MX240, MX480, and MX960 3D Universal Edge Routers. A DPC receives incoming packets from the network and sends outgoing packets to the network. The Packet Forwarding Engines on a DPC are equipped with purpose-built ASICs that perform packet processing and forwarding.

When a slot is not occupied by a DPC, you must insert a blank DPC to fill the empty slot and ensure proper cooling of the system. For complete information about installing and handling DPCs, see the hardware guide for your router.

Related Documentation

- [DPCs Supported on MX240, MX480, and MX960 Routers on page 7](#)
- [Protocols and Applications Supported by DPCs and Enhanced DPCs \(DPC and DPCE-R\) on page 297](#)
- [Protocols and Applications Supported by Enhanced Ethernet Services DPCs \(DPCE-X\) on page 303](#)
- [Protocols and Applications Supported by Enhanced Queuing IP Services DPCs \(DPCE-R-Q\) on page 308](#)
- [Protocols and Applications Supported by Enhanced Queuing Ethernet Services DPCs \(DPCE-X-Q\) on page 312](#)
- [Protocols and Applications Supported by the Multiservices DPC \(MS-DPC\) on page 317](#)

DPCs Supported on MX240, MX480, and MX960 Routers

[Table 3 on page 8](#) lists the DPCs supported by the MX240, MX480, and MX960 routers.

Table 3: DPCs Supported in MX240, MX480, and MX960 Routers

DPC Name	DPC Model Number	Ports	Maximum Throughput per DPC	First Junos OS Release
Gigabit Ethernet				
"Gigabit Ethernet DPC with SFP" on page 90	DPC-R-40GE-SFP EOL (see PSN-2009-06-400)	40	40 Gbps	8.2
"Gigabit Ethernet Enhanced DPC with SFP" on page 92	DPCE-R-40GE-SFP	40	40 Gbps	8.4
"Gigabit Ethernet Enhanced Ethernet Services DPC with SFP" on page 95	DPCE-X-40GE-SFP	40	40 Gbps	8.4
"Gigabit Ethernet Enhanced Queuing Ethernet Services DPC with SFP" on page 98	DPCE-X-Q-40GE-SFP	40	40 Gbps	8.5
"Gigabit Ethernet Enhanced Queuing IP Services DPCs with SFP" on page 101	DPCE-R-Q-20GE-SFP	20	20 Gbps	9.1
"Gigabit Ethernet Enhanced Queuing IP Services DPCs with SFP" on page 101	DPCE-R-Q-40GE-SFP EOL (see PSN-2011-07-314)	40	40 Gbps	8.5
"10-Gigabit Ethernet DPC with XFP" on page 104	DPC-R-4XGE-XFP EOL (see PSN-2009-06-400)	4	40 Gbps	8.2
10-Gigabit Ethernet				
"10-Gigabit Ethernet Enhanced DPCs with XFP" on page 106	DPCE-R-2XGE-XFP EOL (see PSN-2011-02-314)	2	20 Gbps	9.1
"10-Gigabit Ethernet Enhanced DPCs with XFP" on page 106	DPCE-R-4XGE-XFP	4	40 Gbps	8.4
"10-Gigabit Ethernet Enhanced Ethernet Services DPC with XFP" on page 108	DPCE-X-4XGE-XFP	4	40 Gbps	8.4
"10-Gigabit Ethernet Enhanced Queuing Ethernet Services DPC with XFP" on page 110	DPCE-X-Q-4XGE-XFP	4	40 Gbps	8.5
"10-Gigabit Ethernet Enhanced Queuing IP Services DPC with XFP" on page 112	DPCE-R-Q-4XGE-XFP EOL (see PSN-2011-02-314)	4	40 Gbps	8.5
Multirate Ethernet				

Table 3: DPCs Supported in MX240, MX480, and MX960 Routers (*continued*)

DPC Name	DPC Model Number	Ports	Maximum Throughput per DPC	First Junos OS Release
"Multi-Rate Ethernet Enhanced DPC with SFP and XFP" on page 114	DPCE-R-20GE-2XGE	22	40 Gbps	9.2
"Multi-Rate Ethernet Enhanced Ethernet Services DPC with SFP and XFP" on page 118	DPCE-X-20GE-2XGE EOL (see PSN-2011-02-314)	22	40 Gbps	9.2
"Multi-Rate Ethernet Enhanced Queuing IP Services DPC with SFP and XFP" on page 122	DPCE-R-Q-20GE-2XGE	22	40 Gbps	9.3
Tri-Rate Ethernet				
"Tri-Rate Enhanced DPC" on page 128	DPCE-R-40GE-TX	40	40 Gbps	9.1
"Tri-Rate Enhanced Ethernet Services DPC" on page 130	DPCE-X-40GE-TX EOL (see PSN-2011-07-315.)	40	40 Gbps	9.1
Services				
"Multiservices DPC" on page 126	MS-DPC	2 (Not supported)	–	9.3

Related Documentation

- [MX Series DPC Overview on page 7](#)
- [Protocols and Applications Supported by DPCs and Enhanced DPCs \(DPC and DPCE-R\) on page 297](#)
- [Protocols and Applications Supported by Enhanced Ethernet Services DPCs \(DPCE-X\) on page 303](#)
- [Protocols and Applications Supported by Enhanced Queuing IP Services DPCs \(DPCE-R-Q\) on page 308](#)
- [Protocols and Applications Supported by Enhanced Queuing Ethernet Services DPCs \(DPCE-X-Q\) on page 312](#)
- [Protocols and Applications Supported by the Multiservices DPC \(MS-DPC\) on page 317](#)

CHAPTER 3

MPCs Supported on MX Series

- [MX Series MPC Overview on page 11](#)
- [MPCs Supported by MX240, MX480, MX960, MX2010, and MX2020 Routers on page 12](#)

MX Series MPC Overview

Modular Port Concentrators (MPCs) provide packet forwarding services. The MPCs are inserted into a slot in an MX240, MX480, MX960, MX2010, or MX2020 router. Modular Interface Cards (MICs) provide the physical interfaces and install into the MPCs. You can install up to two MICs of different media types in the same MPC as long as the MPC supports those MICs.

A specialized fixed configuration MPC provides higher port density over MICs and combines packet forwarding and Ethernet interfaces onto a single line card. The fixed configuration MPC is inserted into a slot in a router and contains no slots for MICs.

MICs receive incoming packets from the network and transmit outgoing packets to the network. During this process, each MIC performs framing and high-speed signaling for its media type. Before transmitting outgoing data packets through the MIC interfaces, the MPCs encapsulate the packets received. Each MPC is equipped with up to four Junos Trio chipsets, which perform control functions tailored to the MPC's media type.

You must install a high-capacity fan tray to use an MPC. The maximum number of supported MPCs varies per router and hardware configuration:

- MX2020 router—Up to 20 MPCs (For power requirements, see *Calculating AC Power Requirements for MX2020 Routers* and *Calculating DC Power Requirements for MX2020 Routers*.)
- MX2010 router—Up to 10 MPCs (For power requirements, see *Calculating AC Power Requirements for MX2010 Routers* and *Calculating DC Power Requirements for MX2010 Routers*.)
- MX960 router—Up to 12 MPCs (For power requirements, see *Calculating Power Requirements for MX960 Routers*.)
- MX480 router—Up to 6 MPCs (For power requirements, see *Calculating Power Requirements for MX480 Routers*.)
- MX240 router—Up to 3 MPCs (For power requirements, see *Calculating Power Requirements for MX240 Routers*.)

When a slot is not occupied by an MPC, you must insert a blank DPC to fill the empty slot and ensure proper cooling of the system. For complete information about installing and handling MPCs, see the hardware guide for your router.

Related Documentation

- [MPCs Supported by MX240, MX480, MX960, MX2010, and MX2020 Routers on page 12](#)
- [Protocols and Applications Supported by MX240, MX480, MX960, MX2010, and MX2020 MPCs on page 319](#)
- [Protocols and Applications Supported by the MX240, MX480, MX960, MX2010, and MX2020 MPC3E on page 343](#)
- [Protocols and Applications Supported by the MX240, MX480, MX960, MX2010, and MX2020 MPC4Es on page 351](#)
- [Protocols and Applications Supported by the MX240, MX480, MX960, MX2010, and MX2020 MPC5Es on page 358](#)
- [Protocols and Applications Supported by the MX2010 and MX2020 MPC6E on page 365](#)
- [MX Series MIC Overview on page 17](#)
- [MICs Supported by MX Series Routers on page 17](#)

MPCs Supported by MX240, MX480, MX960, MX2010, and MX2020 Routers

Table 4 on page 12 lists the MPCs and their first supported Junos OS release on MX240, MX480, MX960, MX2010, and MX2020 routers.

Table 4: MPCs Supported by MX240, MX480, MX960, MX2010, and MX2020 Routers

MPC Name	MPC Model Number	First Junos OS Release on MX240, MX480, and MX960 Routers	First Junos OS Release on MX2010 Routers	First Junos OS Release on MX2020 Routers
Fixed Configuration MPCs				
"16x10GE MPC" on page 134	MPC-3D-16XGE-SFP	10.0R2	12.3	12.3
"Multiservices MPC" on page 136	MS-MPC	13.2R4	15.1	15.1
"32x10GE MPC4E" on page 169	MPC4E-3D-32XGE-SFPP	12.3R2	12.3R2	12.3R2
"2x100GE + 8x10GE MPC4E" on page 171	MPC4E-3D-2CGE-8XGE	12.3R2	12.3R2	12.3R2
"6x40GE + 24x10GE MPC5E" on page 173	MPC5E-40G10G	13.3R2	13.3R2	13.3R2
"6x40GE + 24x10GE MPC5EQ" on page 175	MPC5EQ-40G10G	13.3R2	13.3R2	13.3R2

Table 4: MPCs Supported by MX240, MX480, MX960, MX2010, and MX2020 Routers (continued)

MPC Name	MPC Model Number	First Junos OS Release on MX240, MX480, and MX960 Routers	First Junos OS Release on MX2010 Routers	First Junos OS Release on MX2020 Routers
"2x100GE + 4x10GE MPC5E" on page 177	MPC5E-100G10G	13.3R3	13.3R3	13.3R3
"2x100GE + 4x10GE MPC5EQ" on page 179	MPC5EQ-100G10G	13.3R3	13.3R3	13.3R3
"MPC7E (Multi-Rate)" on page 182	MPC7E-MRATE	<ul style="list-style-type: none"> • 15.1F4 with Junos Continuity • 16.1R1 and later 	<ul style="list-style-type: none"> • 15.1F4 with Junos Continuity • 16.1R1 and later 	<ul style="list-style-type: none"> • 15.1F4 with Junos Continuity • 16.1R1 and later
"MPC7E 10G" on page 185	MPC7E-10G	<ul style="list-style-type: none"> • 15.1F5 with Junos Continuity • 16.1R1 and later 	<ul style="list-style-type: none"> • 15.1F5 with Junos Continuity • 16.1R1 and later 	<ul style="list-style-type: none"> • 15.1F5 with Junos Continuity • 16.1R1 and later
MPCs				
"MPC1" on page 138	MX-MPC1-3D	10.2	12.3	12.3
"MPC1E" on page 139	MX-MPC1E-3D	11.2R4	12.3	12.3
"MPC1 Q" on page 141	MX-MPC1-3D-Q	10.2	12.3	12.3
"MPC1E Q" on page 143	MX-MPC1E-3D-Q	11.2R4	12.3	12.3
"MPC2" on page 145	MX-MPC2-3D	10.1	12.3	12.3
"MPC2E" on page 147	MX-MPC2E-3D	11.2R4	12.3	12.3
"MPC2 Q" on page 149	MX-MPC2-3D-Q	10.1	12.3	12.3
"MPC2E Q" on page 151	MX-MPC2E-3D-Q	11.2R4	12.3	12.3
"MPC2 EQ" on page 153	MX-MPC2-3D-EQ	10.1	12.3	12.3
"MPC2E EQ" on page 155	MX-MPC2E-3D-EQ	11.2R4	12.3	12.3
"MPC2E P" on page 157	MX-MPC2E-3D-P	12.2	12.3	12.3

Table 4: MPCs Supported by MX240, MX480, MX960, MX2010, and MX2020 Routers (continued)

MPC Name	MPC Model Number	First Junos OS Release on MX240, MX480, and MX960 Routers	First Junos OS Release on MX2010 Routers	First Junos OS Release on MX2020 Routers
“MPC2E NG” on page 159	MX-MPC2E-3D-NG	14.1R4, 14.2R3 and Junos Continuity 15.1	14.1R4, 14.2R3 and Junos Continuity 15.1	14.1R4, 14.2R3 and Junos Continuity 15.1
“MPC2E NG Q” on page 161	MX-MPC2E-3D-NG-Q	14.1R4, 14.2R3 and Junos Continuity 15.1	14.1R4, 14.2R3 and Junos Continuity 15.1	14.1R4, 14.2R3 and Junos Continuity 15.1
“MPC3E” on page 163	MX-MPC3E-3D	12.1	12.3	12.3
“MPC3E NG” on page 165	MX-MPC3E-3D-NG	14.1R4, 14.2R3 and Junos Continuity 15.1	14.1R4, 14.2R3 and Junos Continuity 15.1	14.1R4, 14.2R3 and Junos Continuity 15.1
“MPC3E NG Q” on page 167	MX-MPC3E-3D-NG-Q	14.1R4, 14.2R3 and Junos Continuity 15.1	14.1R4, 14.2R3 and Junos Continuity 15.1	14.1R4, 14.2R3 and Junos Continuity 15.1
“MPC6E” on page 181	MX2K-MPC6E	–	13.3R2	13.3R2
“MPC8E” on page 186	MX2K-MPC8E	–	<ul style="list-style-type: none"> • 15.1F5 with Junos Continuity • 16.1R1 and later 	<ul style="list-style-type: none"> • 15.1F5 with Junos Continuity • 16.1R1 and later
“MPC9E” on page 188	MX2K-MPC9E	–	<ul style="list-style-type: none"> • 15.1F5 with Junos Continuity • 16.1R1 and later 	<ul style="list-style-type: none"> • 15.1F5 with Junos Continuity • 16.1R1 and later

Related Documentation

- [MX Series MPC Overview on page 11](#)
- [Protocols and Applications Supported by MX240, MX480, MX960, MX2010, and MX2020 MPCs on page 319](#)
- [Protocols and Applications Supported by the MX240, MX480, MX960, MX2010, and MX2020 MPC3E on page 343](#)

- [Protocols and Applications Supported by the MX240, MX480, MX960, MX2010, and MX2020 MPC4Es on page 351](#)
- [Protocols and Applications Supported by the MX240, MX480, MX960, MX2010, and MX2020 MPC5Es on page 358](#)
- [Protocols and Applications Supported by the MX2010 and MX2020 MPC6E on page 365](#)
- [Protocols and Applications Supported by the MX240, MX480, MX960, MX2010, and MX2020 MPC7Es on page 372](#)
- [MIC/MPC Compatibility on page 21](#)
- [MX Series MIC Overview on page 17](#)
- [MICs Supported by MX Series Routers on page 17](#)
- [Junos Continuity Software \(Junos OS Release 14.1R4 and Later Releases\)](#)

CHAPTER 4

MICs Supported on MX Series

- [MX Series MIC Overview on page 17](#)
- [MICs Supported by MX Series Routers on page 17](#)
- [MIC/MPC Compatibility on page 21](#)

MX Series MIC Overview

On MX240, MX480, MX960, MX2010, and MX2020 routers, Modular Interface Cards (MICs) install into Modular Port Concentrators (MPCs). On MX5, MX10, MX40, MX80, and MX104 routers, MICs install into built-in MPCs that are part of the router chassis.

MICs provide the physical connections to various network media types. MICs allow different physical interfaces to be supported on a single line card. You can install MICs of different media types on the same router as long as the router supports those MICs.

MICs receive incoming packets from the network and transmit outgoing packets to the network. During this process, each MIC performs framing and high-speed signaling for its media type. Before transmitting outgoing data packets through the MIC interfaces, the MPCs encapsulate the packets received.

MICs are hot-removable and hot-insertable. You can install up to two MICs in the slots in each MPC.

Related Documentation

- [MICs Supported by MX Series Routers on page 17](#)

MICs Supported by MX Series Routers

The following tables list the first supported Junos OS release for the MX Series.

- [Table 5 on page 18](#) lists the first supported Junos OS release for MICs on MX240, MX480, MX960, MX2010, and MX2020 routers.
- [Table 6 on page 20](#) lists the first supported Junos OS release for MICs on MX5, MX10, MX40, MX80, and MX104 routers.

Table 5: MICs Supported by MX240, MX480, MX960, MX2010, and MX2020 Routers

MIC Name	MIC Model Number	Ports	MX240, MX480, and MX960 Routers	MX2010 Routers	MX2020 Routers
ATM					
"ATM MIC with SFP" on page 192	MIC-3D-8OC3-2OC12-ATM	8	12.1	12.3	12.3
DS3/E3					
"DS3/E3 MIC" on page 196	MIC-3D-8DS3-E3, MIC-3D-8CHDS3-E3-B	8	11.4	12.3	12.3
Circuit Emulation					
"Channelized E1/T1 Circuit Emulation MIC" on page 241	MIC-3D-16CHE1-T1-CE	16	12.3	–	–
Gigabit Ethernet					
"Gigabit Ethernet MIC with SFP" on page 199	MIC-3D-20GE-SFP	20	10.1	12.3	12.3
"Gigabit Ethernet MIC with SFP (E)" on page 203	MIC-3D-20GE-SFP-E	20	13.3	13.3	13.3
10-Gigabit Ethernet					
"10-Gigabit Ethernet MICs with XFP" on page 209	MIC-3D-2XGE-XFP	2	10.2	12.3	12.3
"10-Gigabit Ethernet MICs with XFP" on page 209	MIC-3D-4XGE-XFP	4	10.1	12.3	12.3
"10-Gigabit Ethernet MIC with SFP+ (10 Ports)" on page 211	MIC3-3D-10XGE-SFPP	10	12.3	12.3	12.3
"10-Gigabit Ethernet MIC with SFP+ (24 Ports)" on page 213	MIC6-10G	24	-	13.3R2	13.3R2
"10-Gigabit Ethernet OTN MIC with SFP+ (24 Ports)" on page 214	MIC6-10G-OTN	24	-	13.3R3	13.3R3
40-Gigabit Ethernet					
"40-Gigabit Ethernet MIC with QSFP+" on page 216	MIC3-3D-2X40GE-QSFPP	2	12.2	12.3	12.3
100-Gigabit Ethernet					
"100-Gigabit Ethernet MIC with CFP" on page 217	MIC3-3D-1X100GE-CFP	1	12.1	12.3	12.3

Table 5: MICs Supported by MX240, MX480, MX960, MX2010, and MX2020 Routers (*continued*)

MIC Name	MIC Model Number	Ports	MX240, MX480, and MX960 Routers	MX2010 Routers	MX2020 Routers
"100-Gigabit Ethernet MIC with CXP" on page 219	MIC3-3D-1X100GE-CXP	1	12.2	12.3	12.3
"100-Gigabit Ethernet MIC with CXP (4 Ports)" on page 220	MIC6-100G-CXP	4	-	13.3R2	13.3R2
"100-Gigabit Ethernet MIC with CFP2" on page 221	MIC6-100G-CFP2	2	-	13.3R3	13.3R3
100-Gigabit DWDM OTN					
"100-Gigabit DWDM OTN MIC with CFP2-ACO" on page 223	MIC3-100G-DWDM	1	15.1F5	15.1F5	15.1F5
Multi-Rate					
"SONET/SDH OC3/STM1 (Multi-Rate) MICs with SFP" on page 254	MIC-3D-4OC3OC12-1OC48	4	11.2	12.3	12.3
"SONET/SDH OC3/STM1 (Multi-Rate) MICs with SFP" on page 254	MIC-3D-8OC3OC12-4OC48	8	11.2	12.3	12.3
"Channelized SONET/SDH OC3/STM1 (Multi-Rate) MICs with SFP" on page 232	MIC-3D-4CHOC3-2CHOC12	4	11.4	12.3	12.3
"Channelized SONET/SDH OC3/STM1 (Multi-Rate) MICs with SFP" on page 232	MIC-3D-8CHOC3-4CHOC12	8	11.4	12.3	12.3
"Channelized OC3/STM1 (Multi-Rate) Circuit Emulation MIC with SFP" on page 236	MIC-3D-4COC3-1COC12-CE	4	12.2	12.3	12.3
Tri-Rate					
"Tri-Rate MIC" on page 247	MIC-3D-40GE-TX	40	10.2	12.3	12.3
Services					
"Multiservices MIC" on page 253	MS-MIC-16G	0	13.2	13.2	13.2
SONET/SDH					
"SONET/SDH OC192/STM64 MIC with XFP" on page 258	MIC-3D-1OC192-XFP	1	12.2	12.3	12.3

Table 6: MICs Supported by MX5, MX10, MX40, MX80, and MX104 Routers

MIC Name	MIC Model Number	Ports	MX5	MX10	MX40	MX80	MX104
ATM							
"ATM MIC with SFP" on page 192	MIC-3D-8OC3-2OC12-ATM	8	12.1	12.1	12.1	12.1	13.3
DS3/E3							
"DS3/E3 MIC" on page 196	MIC-3D-8DS3-E3, MIC-3D-8CHDS3-E3-B	8	11.4	11.4	11.4	11.4	13.3
Circuit Emulation							
"Channelized E1/T1 Circuit Emulation MIC" on page 241	MIC-3D-16CHE1-T1-CE	16	13.2R2	13.2R2	13.2R2	13.2R2	13.2R2
"Channelized E1/T1 Circuit Emulation MIC (H)" on page 244	MIC-3D-16CHE1-T1-CE-H	16	–	–	–	–	13.2R2
Gigabit Ethernet							
"Gigabit Ethernet MIC with SFP" on page 199	MIC-3D-20GE-SFP	20	11.2R4	11.2R4	11.2R4	10.2	13.2R2
"Gigabit Ethernet MIC with SFP (E)" on page 203	MIC-3D-20GE-SFP-E	20	13.2R2	13.2R2	13.2R2	13.2R2	13.2R2
"Gigabit Ethernet MIC with SFP (EH)" on page 207	MIC-3D-20GE-SFP-EH	20	–	–	–	–	13.2R2
10-Gigabit Ethernet							
"10-Gigabit Ethernet MICs with XFP" on page 209	MIC-3D-2XGE-XFP	2	11.2R4	11.2R4	11.2R4	10.2	13.2R2
Multi-Rate							
"SONET/SDH OC3/STM1 (Multi-Rate) MICs with SFP" on page 254	MIC-3D-4OC3OC12-1OC48	4	11.2R4	11.2R4	11.2R4	11.2	13.3
"SONET/SDH OC3/STM1 (Multi-Rate) MICs with SFP" on page 254	MIC-3D-8OC3OC12-4OC48	8	11.2R4	11.2R4	11.2R4	11.2	13.3
"Channelized SONET/SDH OC3/STM1 (Multi-Rate) MICs with SFP" on page 232	MIC-3D-4CHOC3-2CHOC12	4	11.4	11.4	11.4	11.4	13.3
"Channelized SONET/SDH OC3/STM1 (Multi-Rate) MICs with SFP" on page 232	MIC-3D-8CHOC3-4CHOC12	8	11.4	11.4	11.4	11.4	13.3

Table 6: MICs Supported by MX5, MX10, MX40, MX80, and MX104 Routers (*continued*)

MIC Name	MIC Model Number	Ports	MX5	MX10	MX40	MX80	MX104
"Channelized OC3/STM1 (Multi-Rate) Circuit Emulation MIC with SFP" on page 236	MIC-3D-4COC3-1COC12-CE	4	12.2	12.2	12.2	12.2	13.3
"Channelized OC3/STM1 (Multi-Rate) Circuit Emulation MIC with SFP (H)" on page 239	MIC-4COC3-1COC12-CE-H	-	-	-	-	-	13.3
Tri-Rate							
"Tri-Rate MIC" on page 247	MIC-3D-40GE-TX	40	-	11.2R4	11.2R4	10.2	13.3
Services							
"Multiservices MIC" on page 253	MS-MIC-16G	0	13.2	13.2	13.2	13.2	13.3
			Rear slot only.	Rear slot only.	Rear slot only.	Rear slot only.	
SONET/SDH							
"SONET/SDH OC192/STM64 MIC with XFP" on page 258	MIC-3D-1OC192-XFP	1	12.2	12.2	12.2	12.2	13.3

- Related Documentation**
- [MX Series MIC Overview on page 17](#)
 - [MIC/MPC Compatibility on page 21](#)

MIC/MPC Compatibility

Table 7 on page 21, Table 8 on page 23, Table 9 on page 25, Table 10 on page 27, Table 11 on page 27, and Table 12 on page 27 provide a compatibility matrix for the MICs currently supported by MPC1, MPC2, MPC3, MPC6, MPC8, and MPC9 on MX240, MX480, MX960, MX2010, and MX2020 routers. The table lists the first Junos OS release in which the MPC supports the MIC. For example, Junos OS Release 10.2 is the first release in which the MX-MPC1-3D supports the Gigabit Ethernet MIC with SFP. An en dash indicates that the MIC is not supported.

Table 7: MIC/MPC1 Compatibility

MIC Name	MPC1	MPC1E	MPC1 Q	MPC1E Q
MIC-3D-8OC3-2OC12-ATM (“ATM MIC with SFP” on page 192)	-	-	12.1	12.1R4
MIC-3D-20GE-SFP (“Gigabit Ethernet MIC with SFP” on page 199)	10.2	11.2R4	10.2	11.2R4

Table 7: MIC/MPC1 Compatibility (*continued*)

MIC Name	MPC1	MPC1E	MPC1 Q	MPC1E Q
MIC-3D-20GE-SFP-E (“Gigabit Ethernet MIC with SFP (E)” on page 203)	13.2R2	13.2R2	13.2R2	13.2R2
MIC-3D-2XGE-XFP (“10-Gigabit Ethernet MICs with XFP” on page 209)	10.2	11.2R4	10.2	11.2R4
MIC-3D-4XGE-XFP (“10-Gigabit Ethernet MICs with XFP” on page 209)	—	—	—	—
MIC-3D-40GE-TX (“Tri-Rate MIC” on page 247)	10.2	11.2R4	10.2	11.2R4
MIC-3D-4OC3OC12-1OC48, MIC-3D-8OC3OC12-4OC48 (“SONET/SDH OC3/STM1 (Multi-Rate) MICs with SFP” on page 254)	11.2	11.2R4	11.2	11.2R4
MIC-3D-4COC3-1COC12-CE (“Channelized OC3/STM1 (Multi-Rate) Circuit Emulation MIC with SFP” on page 236)	—	—	12.2	12.2
MIC-3D-1OC192-XFP (“SONET/SDH OC192/STM64 MIC with XFP” on page 258)	12.2	12.2	12.2	12.2
MIC-3D-4CHOC3-2CHOC12, MIC-3D-8CHOC3-4CHOC12 (“Channelized SONET/SDH OC3/STM1 (Multi-Rate) MICs with SFP” on page 232)	—	—	11.4	11.4
MIC-3D-16CHE1-T1-CE (“Channelized E1/T1 Circuit Emulation MIC” on page 241)	13.2	13.2	12.3	12.3
MIC-3D-8DS3-E3, MIC-3D-8CHDS3-E3-B (“DS3/E3 MIC” on page 196) NOTE: You cannot run Channelized DS3 (MIC-3D-8CHDS3-E3) on non-Q MPCs. Channelized DS3 is supported only on Q and EQ-based MPCs.	11.4	11.4	11.4	11.4
MS-MIC-16G (“Multiservices MIC” on page 253)	13.2	13.2	13.2	13.2

Table 8: MIC/MPC2 Compatibility

MIC Name	MPC2	MPC2E	MPC2E NG	MPC2 Q	MPC2E Q	MPC2 EQ	MPC2E EQ	MPC2E P	MPC2E NG Q
MIC-3D-8OC3-2OC12-ATM (“ATM MIC with SFP” on page 192)	—	—	14.1R4, 14.2R3 with Junos Continuity 15.1	12.1	12.1R4	12.1	12.1R4	—	14.1R4, 14.2R3 with Junos Continuity 15.1
MIC-3D-20GE-SFP (“Gigabit Ethernet MIC with SFP” on page 199)	10.1	11.2R4	14.1R4, 14.2R3 with Junos Continuity 15.1	10.1	11.2R4	10.1	11.2R4	12.2	14.1R4, 14.2R3 with Junos Continuity 15.1
MIC-3D-20GE-SFP-E (“Gigabit Ethernet MIC with SFP (E)” on page 203)	13.2R2	13.2R2	14.1R4, 14.2R3 with Junos Continuity 15.1	13.2R2	13.2R2	13.2R2	13.2R2	13.2R2	14.1R4, 14.2R3 with Junos Continuity 15.1
MIC-3D-2XGE-XFP (“10-Gigabit Ethernet MIC with XFP” on page 209)	10.2	11.2R4	14.1R4, 14.2R3 with Junos Continuity 15.1	10.2	11.2R4	10.2	11.2R4	12.2	14.1R4, 14.2R3 with Junos Continuity 15.1
MIC-3D-4XGE-XFP (“10-Gigabit Ethernet MICs with XFP” on page 209)	10.1	11.2R4	14.1R4, 14.2R3 with Junos Continuity 15.1	10.1	11.2R4	10.1	11.2R4	12.2	14.1R4, 14.2R3 with Junos Continuity 15.1
MIC-3D-40GE-TX (“Tri-Rate MIC” on page 247)	10.2	11.2R4	14.1R4, 14.2R3 with Junos Continuity 15.1	10.2	11.2R4	10.2	11.2R4	12.2	14.1R4, 14.2R3 with Junos Continuity 15.1
MIC-3D-4OC3OC12-1OC48, MIC-3D-8OC3OC12-4OC48 (“SONET/SDH OC3/STM1 (Multi-Rate) MICs with SFP” on page 254)	11.4	11.4	14.1R4, 14.2R3 with Junos Continuity 15.1	11.4	11.4	11.4	11.4	-	14.1R4, 14.2R3 with Junos Continuity 15.1

Table 8: MIC/MPC2 Compatibility (*continued*)

MIC Name	MPC2	MPC2E	MPC2E NG	MPC2 Q	MPC2E Q	MPC2 EQ	MPC2E EQ	MPC2E P	MPC2E NG Q
MIC-3D-4COC3-1COC12-CE (“Channelized OC3/STM1 (Multi-Rate) Circuit Emulation MIC with SFP” on page 236)	—	—	15.1 with flexible queuing option	12.2	12.2	12.2	12.2	12.2	14.1R4, 14.2R3 with Junos Continuity 15.1
MIC-3D-1OC192-XFP (“SONET/SDH OC192/STM64 MIC with XFP” on page 258)	12.2	12.2	14.1R4, 14.2R3 with Junos Continuity 15.1	12.2	12.2	12.2	12.2	12.2	14.1R4, 14.2R3 with Junos Continuity 15.1
MIC-3D-4CHOC3-2CHOC12, MIC-3D-8CHOC3-4CHOC12 (“Channelized SONET/SDH OC3/STM1 (Multi-Rate) MICs with SFP” on page 232)	—	—	15.1 with flexible queuing option	11.4	11.4	11.4	11.4	—	15.1 14.1R4, 14.2R3 with Junos Continuity
MIC-3D-16CHE1-T1-CE (“Channelized E1/T1 Circuit Emulation MIC” on page 241)	13.2	13.2	15.1 with flexible queuing option	12.3	12.3	12.3	12.3	—	14.1R4, 14.2R3 with Junos Continuity 15.1
MIC-3D-8DS3-E3, MIC-3D-8CHDS3-E3-B (“DS3/E3 MIC” on page 196) NOTE: You cannot run Channelized DS3 (MIC-3D-8CHDS3-E3) on non-Q MPCs. Channelized DS3 is supported only on Q and EQ-based MPCs.	11.4	11.4	14.1R4, 14.2R3 with Junos Continuity 15.1	11.4	11.4	11.4	11.4	12.2	14.1R4, 14.2R3 with Junos Continuity 15.1
MS-MIC-16G (“Multiservices MIC” on page 253) NOTE: Only one MS-MIC-16G can be installed into any MPC.	13.2	13.2	14.1R4, 14.2R3 with Junos Continuity 15.1	13.2	13.2	13.2	13.2	13.2	14.1R4, 14.2R3 with Junos Continuity 15.1

Table 9: MIC/MPC3 Compatibility

MIC Name	MPC3E	MPC3E NG	MPC3E NG Q
MIC-3D-8OC3-2OC12-ATM (“ATM MIC with SFP” on page 192)	—	14.1R4, 14.2R3 with Junos Continuity 15.1	14.1R4, 14.2R3 with Junos Continuity 15.1
MIC-3D-20GE-SFP (“Gigabit Ethernet MIC with SFP” on page 199)	12.1	14.1R4, 14.2R3 with Junos Continuity 15.1	14.1R4, 14.2R3 with Junos Continuity 15.1
MIC-3D-20GE-SFP-E (“Gigabit Ethernet MIC with SFP (E)” on page 203)	13.2R2	14.1R4, 14.2R3 with Junos Continuity 15.1	14.1R4, 14.2R3 with Junos Continuity 15.1
MIC3-3D-1X100GE-CFP (“100-Gigabit Ethernet MIC with CFP” on page 217)	12.1	14.1R4, 14.2R3 with Junos Continuity 15.1	14.1R4, 14.2R3 with Junos Continuity 15.1
MIC-3D-2XGE-XFP (“10-Gigabit Ethernet MICs with XFP” on page 209)	12.2	14.1R4, 14.2R3 with Junos Continuity 15.1	14.1R4, 14.2R3 with Junos Continuity 15.1
MIC-3D-4XGE-XFP (“10-Gigabit Ethernet MICs with XFP” on page 209)	—	14.1R4, 14.2R3 with Junos Continuity 15.1	14.1R4, 14.2R3 with Junos Continuity 15.1
MIC3-3D-10XGE-SFPP (“10-Gigabit Ethernet MIC with SFP+ (10 Ports)” on page 211)	12.3	14.1R4, 14.2 R3 and Junos Continuity 15.1	14.1R4, 14.2R3 with Junos Continuity 15.1
MIC3-3D-2X40GE-QSFPP (“40-Gigabit Ethernet MIC with QSFP+” on page 216)	12.2	14.1R4, 14.2R3 with Junos Continuity 15.1	14.1R4, 14.2R3 with Junos Continuity 15.1
MIC3-3D-1X100GE-CXP (“100-Gigabit Ethernet MIC with CXP” on page 219)	12.2	14.1R4, 14.2R3 with Junos Continuity 15.1	14.1R4, 14.2R3 with Junos Continuity 15.1
MIC3-100G-DWDM (“100-Gigabit DWDM OTN MIC with CFP2-ACO” on page 223)	15.1F5	15.1F5	15.1F5

Table 9: MIC/MPC3 Compatibility (continued)

MIC Name	MPC3E	MPC3E NG	MPC3E NG Q
MIC-3D-4OC3OC12-1OC48	13.3	14.1R4, 14.2R3 with Junos Continuity	14.1R4, 14.2R3 with Junos Continuity
MIC-3D-8OC3OC12-4OC48 ("SONET/SDH OC3/STM1 (Multi-Rate) MICs with SFP" on page 254)		15.1	15.1
MIC-3D-1OC192-XFP	13.3	14.1R4, 14.2R3 with Junos Continuity	14.1R4, 14.2R3 with Junos Continuity
("SONET/SDH OC192/STM64 MIC with XFP" on page 258)		15.1	15.1
MIC-3D-4COC3-1COC12-CE	—	15.1 with flexible queuing option	14.1R4, 14.2R3 with Junos Continuity
("Channelized OC3/STM1 (Multi-Rate) Circuit Emulation MIC with SFP" on page 236)			15.1
MS-MIC-16G	13.2R2	14.1R4, 14.2R3 with Junos Continuity	14.1R4, 14.2R3 with Junos Continuity
("Multiservices MIC" on page 253)		15.1	15.1
NOTE: On MPC3E, the installation of the Multiservices MIC (MS-MIC-16G) with MIC3-3D-2X40GE-QSFPP, MIC3-3D-10XGE-SFPP, or MIC3-3D-1X100GE-CFP does not meet the NEBS criteria.			
NOTE: Only one MS-MIC-16G can be installed into any MPC.			
MIC-3D-40GE-TX "Tri-Rate MIC" on page 247	—	14.1R4, 14.2R3 with Junos Continuity	14.1R4, 14.2R3 with Junos Continuity
		15.1	15.1
MIC-3D-4OC3OC12-1OC48, MIC-3D-8OC3OC12-4OC48 "SONET/SDH OC3/STM1 (Multi-Rate) MICs with SFP" on page 254	12.1	14.1R4, 14.2R3 with Junos Continuity	14.1R4, 14.2R3 with Junos Continuity
		15.1	15.1
MIC-3D-4CHOC3-2CHOC12, MIC-3D-8CHOC3-4CHOC12 "Channelized SONET/SDH OC3/STM1 (Multi-Rate) MICs with SFP" on page 232	12.1	14.1R4, 14.2R3 with Junos Continuity	14.1R4, 14.2R3 with Junos Continuity
		15.1	15.1

Table 9: MIC/MPC3 Compatibility (continued)

MIC Name	MPC3E	MPC3E NG	MPC3E NG Q
MIC-3D-8DS3-E3, MIC-3D-8CHDS3-E3-B "DS3/E3 MIC" on page 196	12.1	14.1R4, 14.2R3 with Junos Continuity 15.1	14.1R4, 14.2R3 with Junos Continuity 15.1
NOTE: You cannot run Channelized DS3 (MIC-3D-8CHDS3-E3) on non-Q MPCs. Channelized DS3 is supported only on Q and EQ-based MPCs.			

Table 10: MIC/MPC6 Compatibility

MIC Name	MPC6E
MIC6-10G "10-Gigabit Ethernet MIC with SFP+ (24 Ports)" on page 213	13.3R2
MIC6-10G-OTN "10-Gigabit Ethernet OTN MIC with SFP+ (24 Ports)" on page 214	13.3R3
MIC6-100G-CXP "100-Gigabit Ethernet MIC with CXP (4 Ports)" on page 220	13.3R2
MIC6-100G-CFP2 "100-Gigabit Ethernet MIC with CFP2" on page 221	13.3R3

Table 11: MIC/MPC8 Compatibility

MIC Name	MPC8E
MIC-MRATE "MIC MRATE" on page 251	<ul style="list-style-type: none"> 15.1F5 with Junos Continuity 16.1R1 and later

Table 12: MIC/MPC9 Compatibility

MIC Name	MPC9E
MIC-MRATE "MIC MRATE" on page 251	<ul style="list-style-type: none"> 15.1F5 with Junos Continuity 16.1R1 and later

- Related Documentation**
- [MICs Supported by MX Series Routers on page 17](#)
 - [Junos Continuity Software \(Junos OS Release 14.1R4 and Later Releases\)](#)

CHAPTER 5

FPCs and PICs Supported on MX Series

- [MX Series PIC Overview on page 29](#)
- [High Availability Features on page 30](#)
- [FPCs Supported by MX240, MX480, and MX960 Routers on page 30](#)
- [PICs Supported by MX240, MX480, and MX960 Routers on page 30](#)

MX Series PIC Overview

PICs provide the physical connection to various network media types. The PICs are inserted into a slot in a router. You can install PICs of different media types on the same router as long as the router supports those PICs.

PICs receive incoming packets from the network and transmit outgoing packets to the network. During this process, each PIC performs framing and high-speed signaling for its media type. Before transmitting outgoing data packets, the PICs encapsulate the packets received. Each PIC is equipped with a media-specific ASIC that performs control functions tailored to the PIC's media type.

Blank PICs resemble other PICs but do not provide any physical connection or activity. When a slot is not occupied by a PIC, you must insert a blank PIC to fill the empty slot and ensure proper cooling of the system.

MX240, MX480, and MX960 3D Universal Edge Routers support 2 PICs per Flexible PIC Concentrator (FPC). The maximum number of supported PICs varies per router:

- MX960 router—12 PICs
- MX480 router—6 PICs
- MX240 router—2 PICs

Related Documentation

- [High Availability Features on page 30](#)
- [FPCs Supported by MX240, MX480, and MX960 Routers on page 30](#)
- [PICs Supported by MX240, MX480, and MX960 Routers on page 30](#)

High Availability Features

High availability features include Routing Engine redundancy, graceful Routing Engine switchover (GRES), nonstop bridging, nonstop active routing, graceful restart for routing protocols, Virtual Router Redundancy Protocol (VRRP), and unified in-service software upgrade (ISSU). Some high availability features are not supported by all platforms and all PICs. For more information, see the *Unified ISSU System Requirements in the Junos OS High Availability Library for Routing Devices*.

Related Documentation

- [MX Series PIC Overview on page 29](#)
- [FPCs Supported by MX240, MX480, and MX960 Routers on page 30](#)
- [PICs Supported by MX240, MX480, and MX960 Routers on page 30](#)

FPCs Supported by MX240, MX480, and MX960 Routers

An FPC occupies two slots when installed in an MX240, MX480, or MX960 router. The maximum number of supported FPCs varies per router:

- MX960 router—6 FPCs
- MX480 router—3 FPCs
- MX240 router—1 FPC

Table 13 on page 30 lists FPCs supported by MX Series routers.

Table 13: FPCs Supported by MX Series Routers

FPC Type	FPC Name	FPC Model Number	Maximum Number of PICs Supported	Maximum Throughput per FPC (Full-duplex)	First Junos OS Release
3	FPC3	MX-FPC3	2	20 Gbps	9.4
2	FPC2	MX-FPC2	2	10 Gbps	9.5

Related Documentation

- [MX Series PIC Overview on page 29](#)
- [PICs Supported by MX240, MX480, and MX960 Routers on page 30](#)
- [High Availability Features on page 30](#)

PICs Supported by MX240, MX480, and MX960 Routers

Table 14 on page 31 lists the PICs supported by MX240, MX480, and MX960 routers.

Table 14: PICs Supported by MX240, MX480, and MX960 Routers

PIC Name	PIC Model Number	Ports	Type	First Junos OS Release
Channelized IQ PICs				
"Channelized OC12/STM4 Enhanced IQ (IQE) PIC with SFP" on page 262	PB-4CHOC12-STM4-IQE-SFP	4	2	9.5
"Channelized OC48/STM16 Enhanced IQ (IQE) PIC with SFP" on page 267	PB-1CHOC48-STM16-IQE	1	2	9.5
SONET/SDH PICs				
"SONET/SDH OC3/STM1 (Multi-Rate) PIC with SFP" on page 272	PB-4OC3-1OC12-SON2-SFP	4	2	9.5
"SONET/SDH OC12/STM4 (Multi-Rate) PIC with SFP" on page 275	PB-4OC3-4OC12-SON-SFP	4	2	9.5
"SONET/SDH OC48/STM16 Enhanced IQ (IQE) PIC with SFP" on page 278	PC-4OC48-STM16-IQE-SFP	4	3	10.4R2
"SONET/SDH OC48/STM16 (Multi-Rate) PIC with SFP" on page 282	PB-1OC48-SON-B-SFP	1	2	9.5
"SONET/SDH OC48/STM16 PIC with SFP" on page 285	PC-4OC48-SON-SFP	4	3	9.4
"SONET/SDH OC192c/STM64 PIC" on page 288	PC-1OC192-SON-VSR	1	3	9.4
"SONET/SDH OC192c/STM64 PIC with XFP" on page 291	PC-1OC192-SON-XFP	1	3	9.4

- Related Documentation**
- [MX Series PIC Overview on page 29](#)
 - [FPCs Supported by MX240, MX480, and MX960 Routers on page 30](#)
 - [High Availability Features on page 30](#)

CHAPTER 6

Network Interface Specifications

- Supported Network Interface Standards by Transceiver for ACX Series, M Series, MX Series, and T Series Routers on page 33
- Cable Specifications for MX Series Transceivers on page 43
- Gigabit Ethernet 1000BASE Optical Interface Specifications on page 44
- Gigabit Ethernet 1000BASE-T Copper Interface Specifications on page 47
- Ethernet 10BASE-T Copper Interface Specifications on page 48
- Fast Ethernet 100BASE-FX Optical Interface Specifications on page 48
- Fast Ethernet 100BASE-T Copper Interface Specifications on page 49
- Fast Ethernet and Gigabit Ethernet Bidirectional SFP Optical Interface Specifications on page 50
- Gigabit Ethernet SFP CWDM Optical Interface Specifications on page 53
- 10-Gigabit Ethernet 10GBASE Optical Interface Specifications on page 54
- 10-Gigabit Ethernet DWDM OTN Optical Interface Specifications on page 59
- 40-Gigabit Ethernet 40GBASE-R Optical Interface Specifications on page 64
- 100-Gigabit Ethernet 100GBASE-R Optical Interface Specifications on page 68
- 100-Gigabit DWDM OTN CFP2-ACO Optical Interface Specifications on page 72
- SONET/SDH OC3/STM1 Optical Interface Specifications on page 76
- SONET/SDH OC12/STM4 Optical Interface Specifications on page 78
- SONET/SDH OC48/STM16 Optical Interface Specifications on page 80
- SONET/SDH OC192/STM64 Optical Interface Specifications on page 83

Supported Network Interface Standards by Transceiver for ACX Series, M Series, MX Series, and T Series Routers

Table 15 on page 34 and Table 16 on page 41 list the transceivers supported by ACX, M, MX, and T Series devices.



NOTE: Not all transceivers are supported on all devices. To determine which transceivers are supported in a particular device, see the “Cables and Connectors” section for each PIC, MIC, or line card in the *Interface Module Reference* for your device, or see the [Hardware Compatibility Tool](#).

- [Table 15 on page 34](#) lists the supported Ethernet standards for each transceiver.
- [Table 16 on page 41](#) lists the supported SONET standards for each transceiver.

Some transceivers support monitoring by using the operational mode CLI command **show interfaces diagnostics optics**. To determine which transceivers support monitoring, refer to the “Monitoring Available” column in [Table 15 on page 34](#) and [Table 16 on page 41](#). For a description of the monitoring fields displayed by the transceiver, see *show interfaces diagnostics optics (Gigabit Ethernet, 10-Gigabit Ethernet, 40-Gigabit Ethernet, 100-Gigabit Ethernet, and Virtual Chassis Port)* or *show interfaces diagnostics optics (SONET)*.



CAUTION: If you face a problem running a Juniper Networks device that uses a third-party optic or cable, the Juniper Networks Technical Assistance Center (JTAC) can help you diagnose the source of the problem. Your JTAC engineer might recommend that you check the third-party optic or cable and potentially replace it with an equivalent Juniper Networks optic or cable that is qualified for the device.



NOTE: For XFP transceivers that can support either the 10-Gigabit Ethernet or SONET OC192/STM64 specifications, check the standard supported for the device into which the transceiver is installed. For example, the XFP-10G-E-OC192-IR2 transceiver installed in a 10-Gigabit Ethernet PIC supports the 10GBASE-E standard. However, the XFP-10G-E-OC192-IR2 transceiver installed in a SONET OC192/STM64 PIC supports the SONET OC192/STM64 IR2 standard.

[Table 15 on page 34](#) is organized by transmission speed and then alphabetically by model number.

Table 15: Supported Ethernet Standards

Model Number	Transceiver Type	Connector	Monitoring Available	Standard	Specifications
Ethernet 10BASE, Fast Ethernet 100BASE, and Gigabit Ethernet 1000BASE Specifications					
SFP-1FE-FX	SFP	LC	No	100BASE-FX	<ul style="list-style-type: none"> • Fast Ethernet 100BASE-FX Optical Interface Specifications on page 48

Table 15: Supported Ethernet Standards (*continued*)

Model Number	Transceiver Type	Connector	Monitoring Available	Standard	Specifications
SFP-1GE-FE-E-T	SFP	RJ-45	No	10/100/1000 BASE-T	<ul style="list-style-type: none"> Ethernet 10BASE-T Copper Interface Specifications on page 48 Fast Ethernet 100BASE-T Copper Interface Specifications on page 49 Gigabit Ethernet 1000BASE-T Copper Interface Specifications on page 47
SFP-1GE-LH	SFP	LC	Yes	1000BASE-LH	<ul style="list-style-type: none"> Gigabit Ethernet 1000BASE Optical Interface Specifications on page 44
SFP-1GE-LX	SFP	LC	Yes	1000BASE-LX 1000BASE-LX10	<ul style="list-style-type: none"> Gigabit Ethernet 1000BASE Optical Interface Specifications on page 44
SFP-1GE-SX	SFP	LC	Yes	1000BASE-SX	<ul style="list-style-type: none"> Gigabit Ethernet 1000BASE Optical Interface Specifications on page 44
SFP-1GE-T	SFP	RJ-45	No	1000BASE-T	<ul style="list-style-type: none"> Gigabit Ethernet 1000BASE-T Copper Interface Specifications on page 47
SFP-FE20KT13R15	SFP	LC	No	100BASE-BX	<ul style="list-style-type: none"> Fast Ethernet and Gigabit Ethernet Bidirectional SFP Optical Interface Specifications on page 50
SFP-FE20KT15R13	SFP	LC	No	100BASE-BX	<ul style="list-style-type: none"> Fast Ethernet and Gigabit Ethernet Bidirectional SFP Optical Interface Specifications on page 50
SFP-GE10KT13R14	SFP	LC	Yes	1000BASE-BX	<ul style="list-style-type: none"> Fast Ethernet and Gigabit Ethernet Bidirectional SFP Optical Interface Specifications on page 50

Table 15: Supported Ethernet Standards (continued)

Model Number	Transceiver Type	Connector	Monitoring Available	Standard	Specifications
SFP-GE10KT13R15	SFP	LC	Yes	1000BASE-BX	<ul style="list-style-type: none"> Fast Ethernet and Gigabit Ethernet Bidirectional SFP Optical Interface Specifications on page 50
SFP-GE10KT14R13	SFP	LC	Yes	1000BASE-BX	<ul style="list-style-type: none"> Fast Ethernet and Gigabit Ethernet Bidirectional SFP Optical Interface Specifications on page 50
SFP-GE10KT15R13	SFP	LC	Yes	1000BASE-BX	<ul style="list-style-type: none"> Fast Ethernet and Gigabit Ethernet Bidirectional SFP Optical Interface Specifications on page 50
SFP-GE40KM	SFP	LC	Yes	1000BASE-EX	<ul style="list-style-type: none"> Gigabit Ethernet 1000BASE Optical Interface Specifications on page 44
SFP-GE40KT13R15	SFP	LC	Yes	1000BASE-BX	<ul style="list-style-type: none"> Fast Ethernet and Gigabit Ethernet Bidirectional SFP Optical Interface Specifications on page 50
SFP-GE40KT15R13	SFP	LC	Yes	1000BASE-BX	<ul style="list-style-type: none"> Fast Ethernet and Gigabit Ethernet Bidirectional SFP Optical Interface Specifications on page 50
SFP-GE80KCW1470-ET	SFP	LC	Yes	NA	<ul style="list-style-type: none"> Gigabit Ethernet SFP CWDM Optical Interface Specifications on page 53
SFP-GE80KCW1490-ET	SFP	LC	Yes	NA	<ul style="list-style-type: none"> Gigabit Ethernet SFP CWDM Optical Interface Specifications on page 53
SFP-GE80KCW1510-ET	SFP	LC	Yes	NA	<ul style="list-style-type: none"> Gigabit Ethernet SFP CWDM Optical Interface Specifications on page 53

Table 15: Supported Ethernet Standards (*continued*)

Model Number	Transceiver Type	Connector	Monitoring Available	Standard	Specifications
SFP-GE80KCW1530-ET	SFP	LC	Yes	NA	<ul style="list-style-type: none"> Gigabit Ethernet SFP CWDM Optical Interface Specifications on page 53
SFP-GE80KCW1550-ET	SFP	LC	Yes	NA	<ul style="list-style-type: none"> Gigabit Ethernet SFP CWDM Optical Interface Specifications on page 53
SFP-GE80KCW1570-ET	SFP	LC	Yes	NA	<ul style="list-style-type: none"> Gigabit Ethernet SFP CWDM Optical Interface Specifications on page 53
SFP-GE80KCW1590-ET	SFP	LC	Yes	NA	<ul style="list-style-type: none"> Gigabit Ethernet SFP CWDM Optical Interface Specifications on page 53
SFP-GE80KCW1610-ET	SFP	LC	Yes	NA	<ul style="list-style-type: none"> Gigabit Ethernet SFP CWDM Optical Interface Specifications on page 53
10-Gigabit Ethernet 10GBASE Specifications					
PC-1XGE-DWDM-CBAND	Fixed	SC	Yes	10-Gigabit Ethernet dense wavelength-division multiplexing (DWDM)	<ul style="list-style-type: none"> 10-Gigabit Ethernet DWDM Optical Interface Specifications 10-Gigabit Ethernet 10GBASE Optical Interface Specifications on page 54
PC-1XGE-DWDM-OTN	Fixed	SC	Yes	10-Gigabit Ethernet dense wavelength-division multiplexing (DWDM) OTN	<ul style="list-style-type: none"> 10-Gigabit Ethernet DWDM OTN Optical Interface Specifications on page 59 10-Gigabit Ethernet 10GBASE Optical Interface Specifications on page 54
SFPP-10G-CT50-ZR	SFP+	LC	Yes	10GBASE-Z	<ul style="list-style-type: none"> 10-Gigabit Ethernet 10GBASE Optical Interface Specifications on page 54
SFPP-10G-DT-ZRC2	SFP+	LC	Yes	10BASE-Z	<ul style="list-style-type: none"> 10-Gigabit Ethernet 10GBASE Optical Interface Specifications on page 54

Table 15: Supported Ethernet Standards (continued)

Model Number	Transceiver Type	Connector	Monitoring Available	Standard	Specifications
SFPP-10G-ER-OTN	SFP+	LC	Yes	10GBASE-ER	<ul style="list-style-type: none"> 10-Gigabit Ethernet 10GBASE Optical Interface Specifications on page 54
SFPP-10G-LR-OTN	SFP+	LC	Yes	10GBASE-LR	<ul style="list-style-type: none"> 10-Gigabit Ethernet 10GBASE Optical Interface Specifications on page 54
SFPP-10G-ZR-OTN-XT	SFP+	LC	Yes	10GBASE-Z	<ul style="list-style-type: none"> 10-Gigabit Ethernet 10GBASE Optical Interface Specifications on page 54
SFPP-10GE-ER	SFP+	LC	Yes	10GBASE-ER	<ul style="list-style-type: none"> 10-Gigabit Ethernet 10GBASE Optical Interface Specifications on page 54
SFPP-10GE-LR	SFP+	LC	Yes	10GBASE-LR	<ul style="list-style-type: none"> 10-Gigabit Ethernet 10GBASE Optical Interface Specifications on page 54
SFPP-10GE-LRM	SFP+	LC	Yes	10GBASE-LRM	<ul style="list-style-type: none"> 10-Gigabit Ethernet 10GBASE Optical Interface Specifications on page 54
SFPP-10GE-SR	SFP+	LC	Yes	10GBASE-SR	<ul style="list-style-type: none"> 10-Gigabit Ethernet 10GBASE Optical Interface Specifications on page 54
SFPP-10GE-ZR	SFP+	LC	Yes	10GBASE-Z	<ul style="list-style-type: none"> 10-Gigabit Ethernet 10GBASE Optical Interface Specifications on page 54
XENPAK-1XGE-ER	XENPAK	SC	Yes	10GBASE-ER	<ul style="list-style-type: none"> 10-Gigabit Ethernet 10GBASE Optical Interface Specifications on page 54
XENPAK-1XGE-LR	XENPAK	SC	Yes	10GBASE-LR	<ul style="list-style-type: none"> 10-Gigabit Ethernet 10GBASE Optical Interface Specifications on page 54

Table 15: Supported Ethernet Standards (*continued*)

Model Number	Transceiver Type	Connector	Monitoring Available	Standard	Specifications
XENPAK-1XGE-SR	XENPAK	SC	Yes	10GBASE-SR	<ul style="list-style-type: none"> 10-Gigabit Ethernet 10GBASE Optical Interface Specifications on page 54
XENPAK-1XGE-ZR EOL (see PSN-2010-02-649)	XENPAK	SC	Yes	10GBASE-Z	<ul style="list-style-type: none"> 10-Gigabit Ethernet 10GBASE Optical Interface Specifications on page 54
XFP-10G-CBAND-T50-ZR	XFP	LC	Yes	10GBASE-Z 10-Gigabit Ethernet dense wavelength-division multiplexing (DWDM)	<ul style="list-style-type: none"> 10-Gigabit Ethernet 10GBASE Optical Interface Specifications on page 54
XFP-10G-E-OC192-IR2	XFP	LC	Yes	10GBASE-E	<ul style="list-style-type: none"> 10-Gigabit Ethernet 10GBASE Optical Interface Specifications on page 54
XFP-10G-L-OC192-SR1	XFP	LC	Yes	10GBASE-L	<ul style="list-style-type: none"> 10-Gigabit Ethernet 10GBASE Optical Interface Specifications on page 54
XFP-10G-S	XFP	LC	Yes	10GBASE-S	<ul style="list-style-type: none"> 10-Gigabit Ethernet 10GBASE Optical Interface Specifications on page 54
XFP-10G-Z-OC192-LR2	XFP	LC	Yes	10GBASE-Z	<ul style="list-style-type: none"> 10-Gigabit Ethernet 10GBASE Optical Interface Specifications on page 54
40-Gigabit Ethernet 40GBASE Specifications					
CFP-40GBASE-LR4	CFP	SC	Yes	40GBASE-LR4	<ul style="list-style-type: none"> 40-Gigabit Ethernet 40GBASE-R Optical Interface Specifications on page 64
QSFP-40G-LX4	QSFP+	LC	Yes	40GBASE-LX4	<ul style="list-style-type: none"> 40-Gigabit Ethernet 40GBASE-R Optical Interface Specifications on page 64
QSFP-40GE-LX4	QSFP+	LC	Yes	40GBASE-LX4	<ul style="list-style-type: none"> 40-Gigabit Ethernet 40GBASE-R Optical Interface Specifications on page 64

Table 15: Supported Ethernet Standards (continued)

Model Number	Transceiver Type	Connector	Monitoring Available	Standard	Specifications
QSFP-40GBASE-ER4	QSFP+	LC	Yes	40GBASE-ER4	<ul style="list-style-type: none"> 40-Gigabit Ethernet 40GBASE-R Optical Interface Specifications on page 64
QSFP-40GBASE-LR4	QSFP+	LC	Yes	40GBASE-LR4	<ul style="list-style-type: none"> 40-Gigabit Ethernet 40GBASE-R Optical Interface Specifications on page 64
QSFP-40GBASE-SR4	QSFP+	12-fiber MPO	Yes	40GBASE-SR4	<ul style="list-style-type: none"> 40-Gigabit Ethernet 40GBASE-R Optical Interface Specifications on page 64
100-Gigabit Ethernet 100GBASE-R Specifications					
CFP-100GBASE-ER4	CFP	LC	Yes	100GBASE-ER4	<ul style="list-style-type: none"> 100-Gigabit Ethernet 100GBASE-R Optical Interface Specifications on page 68
CFP-GEN2-CGE-ER4	CFP	LC	Yes	100GBASE-ER4	<ul style="list-style-type: none"> 100-Gigabit Ethernet 100GBASE-R Optical Interface Specifications on page 68
CFP-100GBASE-LR4	CFP	SC	Yes	100GBASE-LR4	<ul style="list-style-type: none"> 100-Gigabit Ethernet 100GBASE-R Optical Interface Specifications on page 68
CFP-GEN2-100GBASE-LR4	CFP	LC	Yes	100GBASE-LR4	<ul style="list-style-type: none"> 100-Gigabit Ethernet 100GBASE-R Optical Interface Specifications on page 68
CFP-100GBASE-SR10	CFP	24-fiber MPO	Yes NOTE: Optical power monitoring is not supported.	100GBASE-SR10	<ul style="list-style-type: none"> 100-Gigabit Ethernet 100GBASE-R Optical Interface Specifications on page 68
CFP-100GBASE-ZR	CFP	LC	Yes	None	<ul style="list-style-type: none"> See the Juniper Networks specification in the "100-Gigabit Ethernet 100GBASE-R Optical Interface Specifications" on page 68.

Table 15: Supported Ethernet Standards (continued)

Model Number	Transceiver Type	Connector	Monitoring Available	Standard	Specifications
CFP2-100GBASE-LR4	CFP2	LC	Yes	100GBASE-LR4	<ul style="list-style-type: none"> See the Juniper Networks specification in the “100-Gigabit Ethernet 100GBASE-R Optical Interface Specifications” on page 68.
CFP2-100G-ER4-D	CFP2	LC	Yes	100GBASE-ER4	<ul style="list-style-type: none"> See the Juniper Networks specification in the “100-Gigabit Ethernet 100GBASE-R Optical Interface Specifications” on page 68.
CFP2-100G-SR10-D3	CFP2	24-fiber MPO	Yes	100GBASE-SR10	<ul style="list-style-type: none"> See the Juniper Networks specification in the “100-Gigabit Ethernet 100GBASE-R Optical Interface Specifications” on page 68.
CXP-100GBASE-SR10	CXP	24-fiber MPO	Yes	100GBASE-SR10	<ul style="list-style-type: none"> 100-Gigabit Ethernet 100GBASE-R Optical Interface Specifications on page 68
QSFP28-100G-SR4	QSFP28	12-fiber MPO	Yes	100G-SR4	<ul style="list-style-type: none"> 100-Gigabit Ethernet 100GBASE-R Optical Interface Specifications on page 68
QSFP28-100G-LR4	QSFP28	LC	Yes	100G-LR4	<ul style="list-style-type: none"> 100-Gigabit Ethernet 100GBASE-R Optical Interface Specifications on page 68
TCFP2-100G-C	CFP2-ACO	LC/UPC	Yes	100-Gigabit DWDM OTN	<ul style="list-style-type: none"> 100-Gigabit DWDM OTN CFP2-ACO Optical Interface Specifications on page 72

Table 16 on page 41 is organized by transmission speed and then alphabetically by model number.

Table 16: Supported SONET Standards

Model Number	Transceiver Type	Connector	Monitoring Available	Standard	Specifications
--------------	------------------	-----------	----------------------	----------	----------------

SONET OC3/STM1 Specifications

Table 16: Supported SONET Standards (continued)

Model Number	Transceiver Type	Connector	Monitoring Available	Standard	Specifications
SFP-OC3-IR	SFP	LC	Yes	SONET/SDH OC3/STM1 Intermediate Reach	<ul style="list-style-type: none"> SONET/SDH OC3/STM1 Optical Interface Specifications on page 76
SFP-OC3-LR	SFP	LC	Yes	SONET/SDH OC3/STM1 Long Reach	<ul style="list-style-type: none"> SONET/SDH OC3/STM1 Optical Interface Specifications on page 76
SFP-OC3-SR	SFP	LC	Yes	SONET/SDH OC3/STM1 Multimode	<ul style="list-style-type: none"> SONET/SDH OC3/STM1 Optical Interface Specifications on page 76
SONET OC12/STM4 Specifications					
SFP-OC12-IR	SFP	LC	Yes	SONET/SDH OC12/STM4 Intermediate Reach (IR-1)	<ul style="list-style-type: none"> SONET/SDH OC12/STM4 Optical Interface Specifications on page 78
SFP-OC12-LR	SFP	LC	Yes	SONET/SDH OC12/STM4 Long Reach (LR-1)	<ul style="list-style-type: none"> SONET/SDH OC12/STM4 Optical Interface Specifications on page 78
SFP-OC12-LR2	SFP	LC	Yes	SONET/SDH OC12/STM4 Long Reach (LR-2)	<ul style="list-style-type: none"> SONET/SDH OC12/STM4 Optical Interface Specifications on page 78
SFP-OC12-SR	SFP	LC	Yes	SONET/SDH OC12/STM4 Short Reach (SR-1)	<ul style="list-style-type: none"> SONET/SDH OC12/STM4 Optical Interface Specifications on page 78
SONET OC48/STM16 Specifications					
SFP-1OC48-IR	SFP	LC	No	SONET/SDH OC48/STM16 Intermediate Reach (IR-1)	<ul style="list-style-type: none"> SONET/SDH OC48/STM16 Optical Interface Specifications on page 80
SFP-1OC48-LR	SFP	LC	Yes	SONET/SDH OC48/STM16 Long Reach (LR-2)	<ul style="list-style-type: none"> SONET/SDH OC48/STM16 Optical Interface Specifications on page 80
SFP-1OC48-SR	SFP	LC	No	SONET/SDH OC48/STM16 Short Reach (SR-1)	<ul style="list-style-type: none"> SONET/SDH OC48/STM16 Optical Interface Specifications on page 80
SONET OC192/STM64 Specifications					

Table 16: Supported SONET Standards (continued)

Model Number	Transceiver Type	Connector	Monitoring Available	Standard	Specifications
XFP-10G-E-OC192-IR2	XFP	LC	Yes	SONET/SDH OC192/STM64 Intermediate Reach (IR-2)	<ul style="list-style-type: none"> SONET/SDH OC192/STM64 Optical Interface Specifications on page 83
XFP-10G-L-OC192-SR1	XFP	LC	Yes	SONET/SDH OC192/STM64 Short Reach (SR-1)	<ul style="list-style-type: none"> SONET/SDH OC192/STM64 Optical Interface Specifications on page 83
XFP-10G-Z-OC192-LR2	XFP	LC	Yes	SONET/SDH OC192/STM64 Long Reach (LR-2)	<ul style="list-style-type: none"> SONET/SDH OC192/STM64 Optical Interface Specifications on page 83
SONET OC768/STM256 Specifications					
PD-10C768-SON-SR	Fixed	SC	Yes	SONET/SDH OC768/STM256 Short Reach (SR)	<ul style="list-style-type: none"> SONET/SDH OC768/STM256 Optical Interface Specifications

Related Documentation • [Supported Network Interface Standards by Transceiver for PTX Series Routers](#)

Cable Specifications for MX Series Transceivers

Cable specifications for the CFP2-100G-SR10-D3 MX Series transceiver are described here.



CAUTION: To maintain agency approvals, use only a properly constructed, shielded cable.



TIP: Ensure that you order cables with the correct polarity. Vendors refer to these crossover cables as *key up to key up*, *latch up to latch up*, *Type B*, or *Method B*. If you are using patch panels between two transceivers, ensure that the proper polarity is maintained through the cable plant.

- [CFP2-100G-SR10-D3 on page 43](#)

CFP2-100G-SR10-D3

The MTP optical connector for the CFP2-100G-SR10-D3 is defined in Section 5.6 of the CFP2 Hardware Specification and Section 88.10.3 of IEEE STD 802.3-2012. These specifications include the following requirements:

- Recommended Option A in IEEE STD 802.3-2012 is required.
- Male receptacle. A patchcord with female connector is required to mate with the module.
- Ferrule finish shall be flat polished interface that is compliant with IEC 61754-7.
- Alignment key is key up.

Optical interface shall meet the requirement FT-1435-CORE in *Generic Requirements for Multi-Fiber Optical Connectors*. The module must pass wiggle test defined by IEC 62150-3.

Figure 1 on page 44 shows the MPO optical lane assignments.

Figure 1: MPO Optical Lane Assignments for the CFP2-100G-SR10-D3

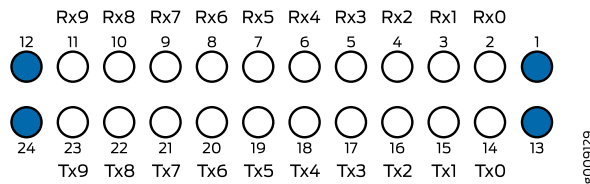

Related Documentation

- [100-Gigabit Ethernet 100GBASE-R Optical Interface Specifications on page 68](#)

Gigabit Ethernet 1000BASE Optical Interface Specifications

The Gigabit Ethernet 1000BASE standards are supported on M Series, MX Series, PTX Series, and T Series routers.

To determine which transceivers support each Gigabit Ethernet 1000BASE standard, see “[Supported Network Interface Standards by Transceiver for ACX Series, M Series, MX Series, and T Series Routers](#)” on page 33 and *Supported Network Interface Standards by Transceiver for PTX Series Routers*. The “Cables and connectors” section in the description for each DPC, MIC, or PIC lists which standards and transceivers are supported.

The standards are organized by distance supported.

- [Gigabit Ethernet 1000BASE-SX Optical Interface Specifications on page 44](#)
- [Gigabit Ethernet 1000BASE-LX Optical Interface Specifications on page 45](#)
- [Gigabit Ethernet 1000BASE-LX10 Optical Interface Specifications on page 46](#)
- [Gigabit Ethernet 1000BASE-EX Optical Interface Specifications on page 46](#)
- [Gigabit Ethernet 1000BASE-LH Optical Interface Specifications on page 47](#)

Gigabit Ethernet 1000BASE-SX Optical Interface Specifications

Table 17 on page 45 shows the optical interface specifications for the 1000BASE-SX standard.

Table 17: Gigabit Ethernet 1000BASE-SX Optical Interface Specifications

Parameter	1000BASE-SX
Rate	1000 Mbps
Optical interface	Multimode
Maximum distance	62.5/125 MMF cable: 656 ft (200 m) 50/125 MMF cable: 1640 ft (500 m)
Transmitter wavelength	770 through 860 nm
Average launch power	-9.5 through 0 dBm
Average receive power	-17 through 0 dBm
Receiver saturation	0 dBm
Receiver sensitivity	-17 dBm

Gigabit Ethernet 1000BASE-LX Optical Interface Specifications

Table 18 on page 45 shows the optical interface specifications for the 1000BASE-LX standard.

Table 18: Gigabit Ethernet 1000BASE-LX Optical Interface Specifications

Parameter	1000BASE-LX
Rate	1000 Mbps
Optical interface	Multimode and single-mode
Maximum distance	62.5/125 and 50/125 MMF cable: 1804.5 ft (550 m) 9/125 SMF cable: 6.2 miles (10 km)
Transmitter wavelength	1270 through 1355 nm
Average launch power	-11.5 through -3 dBm
Average receive power	-19 through -3 dBm
Receiver saturation	-3 dBm
Receiver sensitivity	-19 dBm

Gigabit Ethernet 1000BASE-LX10 Optical Interface Specifications

Table 19 on page 46 shows the optical interface specifications for the 1000BASE-LX10 standard.

Table 19: Gigabit Ethernet 1000BASE-LX10 Optical Interface Specifications

Parameter	1000BASE-LX10
Rate	1000 Mbps
Optical interface	Single-mode
Maximum distance	9/125 SMF cable: 6.2 miles (10 km)
Transmitter wavelength	1270 through 1355 nm
Average launch power	-11.5 through -3 dBm
Average receive power	-19 through -3 dBm
Receiver saturation	-3 dBm
Receiver sensitivity	-19 dBm

Gigabit Ethernet 1000BASE-EX Optical Interface Specifications

Table 19 on page 46 shows the optical interface specifications for the 1000BASE-EX standard.

Table 20: Gigabit Ethernet 1000BASE-EX Optical Interface Specifications

Parameter	1000BASE-EX
Rate	1000 Mbps
Optical interface	Single-mode
Maximum distance	9/125 SMF cable: 24.85 miles (40 km)
Transmitter wavelength	1260 through 1360 nm
Average launch power	-4.5 through 0 dBm
Average receive power	-22.5 through -3 dBm
Receiver saturation	-3 dBm
Receiver sensitivity	-22.5 dBm

Gigabit Ethernet 1000BASE-LH Optical Interface Specifications

Table 21: Gigabit Ethernet 1000BASE-LH Optical Interface Specifications

Parameter	1000BASE-LH
Rate	1000 Mbps
Optical interface	Single-mode
Maximum distance	9/125 SMF cable: 43.5 miles (70 km)
Transmitter wavelength	1460 through 1580 nm
Average launch power	-3 through +3 dBm
Average receive power	-20 through -3 dBm
Receiver saturation	-3 dBm
Receiver sensitivity	-20 dBm

Related Documentation

- [Supported Network Interface Standards by Transceiver for ACX Series, M Series, MX Series, and T Series Routers on page 33](#)
- [Supported Network Interface Standards by Transceiver for PTX Series Routers](#)

Gigabit Ethernet 1000BASE-T Copper Interface Specifications

The 1000BASE-T copper standard is supported on M Series, MX Series, and T Series routers.

To determine which transceivers support the 1000BASE-T copper standard, see “Supported Network Interface Standards by Transceiver for ACX Series, M Series, MX Series, and T Series Routers” on page 33. The “Cables and connectors” section in the description for each MIC or PIC lists which standards and transceivers are supported for that device.

Table 22 on page 47 shows the copper interface specifications for the 1000BASE-T standard.

Table 22: 1000BASE-T Copper Interface Specifications

Parameter	1000BASE-T
Rate	1000 Mbps autosensing
Distance	328 ft (100 m)

Table 22: 1000BASE-T Copper Interface Specifications (*continued*)

Parameter	1000BASE-T
Cable	Four-pair, Category 5 shielded twisted-pair

Related Documentation

- [Supported Network Interface Standards by Transceiver for ACX Series, M Series, MX Series, and T Series Routers on page 33](#)

Ethernet 10BASE-T Copper Interface Specifications

The 10BASE-T copper standard is supported on M Series, MX Series, and T Series routers.

To determine which transceivers support the 10BASE-T copper standard, see “[Supported Network Interface Standards by Transceiver for ACX Series, M Series, MX Series, and T Series Routers](#)” on page 33. The “Cables and connectors” section in the description for each MIC or PIC lists which standards and transceivers are supported for that device.

[Table 23 on page 48](#) shows the copper interface specifications for the 10BASE-T standard.

Table 23: 10BASE-T Copper Interface Specifications

Parameter	10BASE-T
Rate	10 Mbps
Distance	328 ft (100 m)
Cable	Four-pair, Category 5 shielded twisted-pair

Related Documentation

- [Supported Network Interface Standards by Transceiver for ACX Series, M Series, MX Series, and T Series Routers on page 33](#)

Fast Ethernet 100BASE-FX Optical Interface Specifications

The 100BASE-FX standard is supported on M Series, MX Series, and T Series routers.

To determine which transceivers support the 100BASE-FX standard, see “[Supported Network Interface Standards by Transceiver for ACX Series, M Series, MX Series, and T Series Routers](#)” on page 33. The “Cables and connectors” section in the description for each MIC or PIC lists which standards and transceivers are supported for that device.

[Table 24 on page 48](#) shows the optical interface specifications for the 100BASE-FX standard.

Table 24: Fast Ethernet 100BASE-FX Optical Interface Specifications

Parameter	100BASE-FX
Rate	100 Mbps

Table 24: Fast Ethernet 100BASE-FX Optical Interface Specifications (*continued*)

Parameter	100BASE-FX
Optical interface	Multimode
Maximum distance	50/125 MMF cable: 1640 ft (500 m) 62.5/125 MMF cable: 6562 ft (2 km)
Transmitter wavelength	1270 through 1380 nm
Average launch power	-19 through -14 dBm
Average receive power	-31 through -14 dBm
Receiver saturation	-14 dBm
Receiver sensitivity	-31 dBm

- Related Documentation**
- [Supported Network Interface Standards by Transceiver for ACX Series, M Series, MX Series, and T Series Routers on page 33](#)

Fast Ethernet 100BASE-T Copper Interface Specifications

The 100BASE-T copper standard is supported on M Series, MX Series, and T Series routers.

To determine which transceivers support the 100BASE-T copper standard, see “[Supported Network Interface Standards by Transceiver for ACX Series, M Series, MX Series, and T Series Routers](#)” on page 33. The “Cables and Connectors” section in the description for each MIC or PIC lists which standards and transceivers are supported for that device.

[Table 25 on page 49](#) shows the copper interface specifications for the 100BASE-T standard.

Table 25: Ethernet 100BASE-T Copper Interface Specifications

Parameter	100BASE-T
Rate	100 Mbps
Distance	328 ft (100 m)
Cable	Four-pair, Category 5 shielded twisted-pair

- Related Documentation**
- [Supported Network Interface Standards by Transceiver for ACX Series, M Series, MX Series, and T Series Routers on page 33](#)

Fast Ethernet and Gigabit Ethernet Bidirectional SFP Optical Interface Specifications

The bidirectional SFP standards are supported on M Series, MX Series, and T Series routers.

To determine which transceivers support each bidirectional SFP standard, see “Supported Network Interface Standards by Transceiver for ACX Series, M Series, MX Series, and T Series Routers” on page 33. The “Cables and connectors” section in the description for each MIC or PIC lists which standards and transceivers are supported for that device.

The standards are organized by distance supported.

- [Fast Ethernet 100BASE-BX Bidirectional SFP Optical Interface Specifications on page 50](#)
- [Gigabit Ethernet 1000BASE-BX Bidirectional SFP \(U 13/14 and D 14/13\) Optical Interface Specifications on page 51](#)
- [Gigabit Ethernet 1000BASE-BX Bidirectional SFP \(U 13/15 and D 15/13\) Optical Interface Specifications on page 52](#)
- [Gigabit Ethernet 1000BASE-BX Bidirectional SFP \(40 U 13/15 and D 15/13\) Optical Interface Specifications on page 52](#)

Fast Ethernet 100BASE-BX Bidirectional SFP Optical Interface Specifications

Table 26 on page 50 shows the optical specifications for 100BASE-BX bidirectional SFPs. 100BASE-BX bidirectional interfaces are supported in Junos OS Release 9.6 and later and must be used in pairs.

Table 26: Fast Ethernet 100BASE-BX Bidirectional SFP Optical Interface Specifications

Parameter	100BASE-BX-U	100BASE-BX-D
Pairs with	100BASE-BX-D	100BASE-BX-U
Transceiver model number	SFP-FE20KT13R15	SFP-FE20KT15R13
Rate	100 Mbps	100 Mbps
Optical interface	Single-mode	Single-mode
Transceiver type	SFP	SFP
Standard	100BASE-BX IEEE 802.3-2005	100BASE-BX IEEE 802.3-2005
Maximum distance	9/125 SMF cable: 12.4 miles (20 km)	9/125 SMF cable: 12.4 miles (20 km)
Transmitter wavelength	1260 through 1360 nm	1480 through 1580 nm
Average launch power	-14 through -8 dBm	-14 through -8 dBm

Table 26: Fast Ethernet 100BASE-BX Bidirectional SFP Optical Interface Specifications (continued)

Parameter	100BASE-BX-U	100BASE-BX-D
Average receive power	-45 through -8 dBm	-45 through -8 dBm
Receiver saturation	-8 dBm	-8 dBm
Receiver sensitivity	-45 dBm	-45 dBm

Gigabit Ethernet 1000BASE-BX Bidirectional SFP (U 13/14 and D 14/13) Optical Interface Specifications

Table 27 on page 51 shows the optical specifications for 1000BASE-BX bidirectional SFPs. 1000BASE-BX bidirectional interfaces are supported in Junos OS Release 9.0 and later and must be used in pairs.

Table 27: Gigabit Ethernet 1000BASE-BX Bidirectional SFP (U 13/14 and D 14/13) Optical Interface Specifications

Parameter	1000BASE-BX10-U 13/14	1000BASE-BX10-D 14/13
Pairs with	1000BASE-BX10-D 14/13	1000BASE-BX10-U 13/14
Transceiver model number	SFP-GE10KT13R14	SFP-GE10KT14R13
Rate	1000 Mbps	1000 Mbps
Optical interface	Single-mode	Single-mode
Transceiver type	SFP	SFP
Standard	IEEE 802.3-2005	IEEE 802.3-2005
Maximum distance	9/125 SMF cable: 6.2 miles (10 km)	9/125 SMF cable: 6.2 miles (10 km)
Transmitter wavelength	1260 through 1360 nm	1480 through 1500 nm
Average launch power	-9 through -3 dBm	-9 through -3 dBm
Average receive power	-19.5 through -3 dBm	-19.5 through -3 dBm
Receiver saturation	-3 dBm	-3 dBm
Receiver sensitivity	-19.5 dBm	-19.5 dBm

Gigabit Ethernet 1000BASE-BX Bidirectional SFP (U 13/15 and D 15/13) Optical Interface Specifications

Table 29 on page 52 shows the optical specifications for 1000BASE-BX bidirectional SFPs. 1000BASE-BX bidirectional interfaces are supported in Junos OS Release 9.0 and later and must be used in pairs.

Table 28: Gigabit Ethernet 1000BASE-BX Bidirectional SFP (U 13/15 and D 15/13) Optical Interface Specifications

Parameter	1000BASE-BX10-U 13/15	1000BASE-BX10-D 15/13
Pairs with	1000BASE-BX10-D 15/13	1000BASE-BX10-U 13/15
Transceiver model number	SFP-GE10KT13R15	SFP-GE10KT15R13
Rate	1000 Mbps	1000 Mbps
Optical interface	Single-mode	Single-mode
Transceiver type	SFP	SFP
Standard	Multivendor agreement	Multivendor agreement
Maximum distance	9/125 SMF cable: 6.2 miles (10 km)	9/125 SMF cable: 6.2 miles (10 km)
Transmitter wavelength	1270 through 1360 nm	1530 through 1570 nm
Average launch power	-9 through -3 dBm	-9 through -3 dBm
Average receive power	-20 through -3 dBm	-20 through -3 dBm
Receiver saturation	-3 dBm	-3 dBm
Receiver sensitivity	-20 dBm	-20 dBm

Gigabit Ethernet 1000BASE-BX Bidirectional SFP (40 U 13/15 and D 15/13) Optical Interface Specifications

Table 28 on page 52 shows the optical specifications for 1000BASE-BX bidirectional SFPs. 1000BASE-BX bidirectional interfaces are supported in JUNOS 9.0 and later and must be used in pairs.

Table 29: Gigabit Ethernet 1000BASE-BX Bidirectional SFP (40 U 13/15 and D 15/13) Optical Interface Specifications

Parameter	1000BASE-BX40-U 13/15	1000BASE-BX40-D 15/13
Pairs with	1000BASE-BX40-D 15/13	1000BASE-BX40-U 13/15

Table 29: Gigabit Ethernet 1000BASE-BX Bidirectional SFP (40 U 13/15 and D 15/13) Optical Interface Specifications (continued)

Parameter	1000BASE-BX40-U 13/15	1000BASE-BX40-D 15/13
Transceiver model number	SFP-GE40KT13R15	SFP-GE40KT15R13
Rate	1000 Mbps	1000 Mbps
Optical interface	Single-mode	Single-mode
Transceiver type	SFP	SFP
Standard	Multivendor agreement	Multivendor agreement
Maximum distance	9/125 SMF cable: 24.9 miles (40 km)	9/125 SMF cable: 24.9 miles (40 km)
Transmitter wavelength	1260 through 1360 nm	1530 through 1570 nm
Average launch power	-3 through 2 dBm	-7 through 2 dBm
Average receive power	-23 through -3 dBm	-23 through -3 dBm
Receiver saturation	-3 dBm	-3 dBm
Receiver sensitivity	-23 dBm	-23 dBm

Related Documentation • [Supported Network Interface Standards by Transceiver for ACX Series, M Series, MX Series, and T Series Routers on page 33](#)

Gigabit Ethernet SFP CWDM Optical Interface Specifications

These transceivers are supported on MX Series routers. For more information about transceivers, see [“Supported Network Interface Standards by Transceiver for ACX Series, M Series, MX Series, and T Series Routers” on page 33](#). The “Cables and connectors” section in the description for each DPC, MIC, or PIC lists which standards and transceivers are supported.

[Table 30 on page 54](#) shows the SFP CWDM optical interface specifications for the following transceivers. These transceivers support CWDM (Coarse Wavelength Division Multiplexing) applications:

- SFP-GE80KCW1470-ET
- SFP-GE80KCW1490-ET
- SFP-GE80KCW1510-ET
- SFP-GE80KCW1530-ET
- SFP-GE80KCW1550-ET

- SFP-GE80KCW1570-ET
- SFP-GE80KCW1590-ET
- SFP-GE80KCW1610-ET

Table 30: Gigabit Ethernet SFP CWDM Optical Interface Specifications

Rate	Rate transparent Supports speeds of 125 through 1250 Mbps
Optical interface	Single-mode
Maximum distance	9/125 SMF cable: 49.7 miles (80 km)
Transmitter wavelengths	SFP-GE80KCW1470-ET: 1471 nm SFP-GE80KCW1490-ET: 1491 nm SFP-GE80KCW1510-ET: 1511 nm SFP-GE80KCW1530-ET: 1531 nm SFP-GE80KCW1550-ET: 1551 nm SFP-GE80KCW1570-ET: 1571 nm SFP-GE80KCW1590-ET: 1591 nm SFP-GE80KCW1610-ET: 1611 nm
Average launch power	0 through 5 dBm
Average receive power	-24 through -3 dBm
Receiver saturation	-3 dBm
Receiver sensitivity	-24 dBm

Related Documentation

- [Supported Network Interface Standards by Transceiver for ACX Series, M Series, MX Series, and T Series Routers on page 33](#)

10-Gigabit Ethernet 10GBASE Optical Interface Specifications

The 10-Gigabit Ethernet optical interface standards are supported on M120 routers, M320 routers, MX Series routers, T Series routers, and PTX Series routers.

To determine which transceivers support each 10GBASE standard, see [“Supported Network Interface Standards by Transceiver for ACX Series, M Series, MX Series, and T Series Routers” on page 33](#) and [Supported Network Interface Standards by Transceiver for PTX Series Routers](#). The “Cables and Connectors” section in the description for each MIC or PIC lists which standards and transceivers are supported for that device.



NOTE: Some XFP transceivers can support either the 10-Gigabit Ethernet or SONET/SDH OC192/STM64 specifications. Check the standard supported for the device in which the transceiver is installed. For example, the XFP-10G-E-OC192-IR2 transceiver installed in a 10-Gigabit Ethernet PIC supports the 10GBASE-E standard. However, the XFP-10G-E-OC192-IR2 transceiver installed in a SONET/SDH OC192/STM64 PIC supports the SONET/SDH OC192/STM64 IR2 standard.

The specifications are organized by distance supported.

- [10GBASE-LRM Specifications on page 55](#)
- [10GBASE-S Specifications on page 55](#)
- [10GBASE-L Specifications on page 56](#)
- [10GBASE-E Specifications on page 57](#)
- [10GBASE-Z Specifications on page 57](#)

10GBASE-LRM Specifications

[Table 31 on page 55](#) shows the optical interface specifications for the 10GBASE-LRM standard.

Table 31: 10GBASE-LRM Optical Interface Specifications

Parameter	10GBASE-LRM
Optical interface	Multimode
Standard	IEEE 802.3aq–2006
Maximum distance	62.5/125 MMF cable, 500 MHz-km: 220 m (722 ft) 50/125 MMF cable, 500 MHz-km: 220 m (722 ft)
Transmitter wavelength	1260 through 1355 nm
Average launch power	–6.5 through +0.5 dBm
Average receive power	–6.5 through +1.5 dBm
Receiver saturation	+1.5 dBm
Receiver sensitivity	–6.5 dBm

10GBASE-S Specifications

[Table 32 on page 56](#) shows the optical interface specifications for the 10GBASE-SR and 10GBASE-SW standards.



NOTE: The XFP-10G-L-OC192-SR1 transceiver supports single-mode fiber and the 10GBASE-L optical interface specifications.

Table 32: 10GBASE-S (10GBASE-SR and 10GBASE-SW) Optical Interface Specifications

Parameter	10GBASE-S
Optical interface	Multimode
Standard	IEEE 802.3ae–2002
Maximum distance	50/125 MMF cable, 2000 MHz-km: 300 m (948 ft) 50/125 MMF cable, 500 MHz-km: 80 m (269 ft) 50/125 MMF cable, 400 MHz-km: 66 m (217 ft) 62.5/125 MMF cable, 200 MHz-km: 33 m (108 ft) 62.5/125 MMF cable, 160 MHz-km: 26 m (85 ft)
Transmitter wavelength	840 through 860 nm
Average launch power	–4.5 through –1.0 dBm
Average receive power	–9.9 through –1.0 dBm
Receiver saturation	–1.0 dBm
Receiver sensitivity	–9.9 dBm

10GBASE-L Specifications

Table 33 on page 56 shows the optical interface specifications for the 10GBASE-LR and 10GBASE-LW standards.

Table 33: 10GBASE-L (10GBASE-LR and 10GBASE-LW) Optical Interface Specifications

Parameter	10GBASE-L
Optical interface	Single-mode
Standard	IEEE 802.3ae–2002
Maximum distance	9/125 SMF cable: 10 km (6.2 miles)
Transmitter wavelength	1260 through 1355 nm
Average launch power	–8.2 through 0.5 dBm

Table 33: 10GBASE-L (10GBASE-LR and 10GBASE-LW) Optical Interface Specifications (continued)

Parameter	10GBASE-L
Average receive power	-14.4 through 0.5 dBm
Receiver saturation	0.5 dBm
Receiver sensitivity	-14.4 dBm

10GBASE-E Specifications

Table 34 on page 57 shows the optical interface specifications for the 10GBASE-ER and 10GBASE-EW standards.

Table 34: 10GBASE-E (10GBASE-ER and 10GBASE-EW) Optical Interface Specifications

Parameter	10GBASE-E
Optical interface	Single-mode
Standard	IEEE 802.3ae-2002
Maximum distance	9/125 SMF cable: 40 km (24.8 miles); distances greater than 30 km (18.6 miles) are considered to be engineered links. NOTE: Any distance greater than 30 km requires engineered links that must be field-tested to verify the conformance of the 11 dB channel insertion loss specification. EANSI/TIA/EIA-526-7/Method A1 describes the insertion loss measurement of installed fiber-optic cables.
Transmitter wavelength	1530 through 1565 nm
Average launch power	-4.7 through 4.0 dBm
Average receive power	-15.8 through -1.0 dBm
Receiver saturation	-1.0 dBm
Receiver sensitivity	-15.8 dBm

10GBASE-Z Specifications

Table 35 on page 58 shows the optical interface specifications for the 10GBASE-ZR and 10GBASE-ZW transceiver.

Table 35: 10GBASE-Z (10GBASE-ZR and 10GBASE-ZW) Optical Interface Specifications

Parameter	10GBASE-Z
Optical interface	Single-mode
Standard	Multivendor
Maximum distance	9/125 SMF cable: 80 km (49.6 miles)
Transmitter wavelength	<p>1530 through 1565 nm</p> <p>1528.38 through 1568.77 nm (tunable) for XFP-10G-CBAND-T50-ZR</p> <p>1528.38 through 1568.77 nm (tunable) for SFPP-10G-CT50-ZR</p> <p>1528.38 through 1568.77 nm (tunable) for SFPP-10G-DT-ZRC2</p>
Average launch power	<p>0 through 4.0 dBm for XENPAK-1XGE-ZR, XFP-10G-CBAND-T50-ZR, XFP-10G-Z-OC192-LR2, and SFPP-10G-ZR-OTN-XT</p> <p>0 through 5.0 dBm for SFPP-10GE-ZR</p> <p>-1.0 through +3.0 dBm for SFPP-10G-CT50-ZR and SFPP-10G-DT-ZRC2</p>
Average receive power	<p>-25.0 through -7.0 dBm for XENPAK-1XGE-ZR</p> <p>-23.0 through -7.0 dBm for XFP-10G-CBAND-T50-ZR</p> <p>-24.0 through -7.0 dBm for XFP-10G-Z-OC192-LR2</p> <p>-23.0 through -8.0 dBm for SFPP-10GE-ZR</p> <p>-24.0 through -8.0 dBm for SFPP-10G-CT50-ZR</p> <p>-24.0 through -7.0 dBm (9.95, 10.312, and 10.709 Gbps) for SFPP-10G-DT-ZRC2</p> <p>-24.0 through -8.0 dBm for SFPP-10G-ZR-OTN-XT</p>
Receiver saturation	<p>-7.0 dBm for XENPAK-1XGE-ZR, XFP-10G-CBAND-T50-ZR, XFP-10G-Z-OC192-LR2, SFPP-10G-CT50-ZR, SFPP-10G-DT-ZRC2, and SFPP-10G-ZR-OTN-XT</p> <p>-8.0 dBm for SFPP-10GE-ZR</p>

Table 35: 10GBASE-Z (10GBASE-ZR and 10GBASE-ZW) Optical Interface Specifications (continued)

Parameter	10GBASE-Z
Receiver sensitivity	<p>–25.0 dBm for XENPAK-1XGE-ZR</p> <p>–23.0 dBm for XFP-10G-CBAND-T50-ZR</p> <p>–24.0 dBm for XFP-10G-Z-OC192-LR2</p> <p>–23.0 dBm for SFPP-10GE-ZR</p> <p>–23.0 dBm for SFPP-10G-CT50-ZR</p> <p>For SFPP-10G-DT-ZRC2:</p> <ul style="list-style-type: none"> –24.0 dBm (9.95, 10.312, and 10.709 Gbps, BER < 1×10^{-12}, no FEC) –25.0 dBm (11.049 and 11.095 Gbps, BER < 1×10^{-6}, pre-FEC) <p>NOTE: When you use SFPP-10G-DT-ZRC2 in OTU1e (11.049 Gbps) or OTU2e (11.095 Gbps) applications, you must enable forward error correction (FEC) to achieve target receiver sensitivity. To enable FEC mode, use the fec command at the [edit interfaces <i>interface-name</i> otn-options] hierarchy level (see <i>fec</i>).</p> <p>–23.0 dBm for SFPP-10G-ZR-OTN-XT</p>

Related Documentation

- [Supported Network Interface Standards by Transceiver for ACX Series, M Series, MX Series, and T Series Routers on page 33](#)
- [Supported Network Interface Standards by Transceiver for PTX Series Routers](#)

10-Gigabit Ethernet DWDM OTN Optical Interface Specifications

The 10-Gigabit Ethernet DWDM OTN PIC is supported on M120 routers and T Series routers.

To determine which transceivers support each 10GBASE standard, see “[Supported Network Interface Standards by Transceiver for ACX Series, M Series, MX Series, and T Series Routers](#)” on page 33. The “Cables and connectors” section in the description for each MIC or PIC lists which standards and transceivers are supported for that device.

- [10-Gigabit Ethernet DWDM OTN Optical Interface Specifications on page 60](#)
- [10-Gigabit Ethernet DWDM OTN Supported Wavelengths on page 62](#)
- [PC-1XGE-DWDM-OTN Optical Signal-to-Noise Ratio \(OSNR\) Performance on page 64](#)

10-Gigabit Ethernet DWDM OTN Optical Interface Specifications

Table 36 on page 60 shows the optical interface specifications for the 10-Gigabit Ethernet DWDM OTN PIC transceiver.

Table 36: 10-Gigabit Ethernet DWDM OTN Optical Interface Specifications

Model number	<ul style="list-style-type: none"> PIC model number: PC-1XGE-DWDM-OTN
Features	<ul style="list-style-type: none"> 10-Gigabit digital wrapper with over-clocked G.709 framing Generic Reed-Solomon forward error correction (GFEC) and enhanced forward error correction (EFEC) to transport 10GBASE-R (10-Gigabit Ethernet LAN PHY) Reduced cost of deploying and maintaining the network due to: <ul style="list-style-type: none"> Fewer optical-electrical-optical (OEO) conversions Fewer optical amplifiers and regenerators 89 tunable wavelengths (channels) supported per DWDM-OTN module Link fault switchover
Transceiver type	<ul style="list-style-type: none"> Dense wavelength division multiplexing (DWDM) module
Standards	<ul style="list-style-type: none"> ITU-T G.709—Interfaces for the Optical Transport Network (OTN). The PC-1XGE-DWDM-OTN PIC supports two OTN extended mappings: <ul style="list-style-type: none"> Supplement 43, section 7.1, optical channel payload unit 2e (OPU2e). This mapping inserts the original 10GE LAN PHY signal into a “digital wrapper” with overclocked G.709 framing that results in a line rate of 11.1 Gbps instead of the standard 10.7 Gbps. Supplement 43, section 7.2, optical channel payload unit 1e (OPU1e). This mapping inserts the original 10GE LAN PHY signal into a “digital wrapper” with overclocked G.709 framing, but without the use of fixed stuff bytes, that results in a line rate of 11.05 Gbps instead of the standard 10.7 Gbps. <p>See <i>ITU-T Series G Supplement 43, ver 02/2008</i> for more information about OPU2e and OPU1e extended mappings.</p> ITU-T G.975—GFEC ITU-T G.975.1—Enhanced FEC ITU-T G.694.1—Spectral grids for WDM applications: DWDM frequency grid Series G: Transmission Systems and Media, Digital Systems and Networks Transmission media characteristics-Characteristics of optical components and subsystems IEEE 802.3ae—2005 RFC 3591—Definitions of Managed Objects for the Optical Interface Type
Optical interface	<ul style="list-style-type: none"> Single-mode optical fiber
Line interface	<ul style="list-style-type: none"> Line rate: <ul style="list-style-type: none"> 10GE LAN PHY: 10.3125 Gbps (pass-through) G.709 LAN PHY without fixed stuff bytes: 11.049 Gbps G.709 LAN PHY with fixed stuff bytes: 11.0957 Gbps Transmit line rate deviation: G.709 LAN PHY modes: +/-20 ppm Dispersion window: +/-1200 ps/nm or +/-1600 ps/nm (maximum) FEC type (software selectable): Generic Reed-Solomon RS (255, 239) code computed as specified in Annex A/G. 709 (GFEC) or enhanced (EFEC)

Table 36: 10-Gigabit Ethernet DWDM OTN Optical Interface Specifications (*continued*)

Optical transmitter	<ul style="list-style-type: none"> • Transmitter type: LiNbO₃ MZI (Lithium Niobate Mach-Zehnder Interferometer) • Modulation format: Nonreturn-to-zero (NRZ) • Channel-plan wavelength range: 1528.77 through 1563.86 nm • Channel-plan frequency range: 191.7 through 196.1 THz • Channel spacing: 50 GHz • Channel tunability: 89 channels—see Table 37 on page 63 • Output power (on): +3 to +7 dBm • Output power (off): ≤ -40 dBm • Output power stability: -1.5 to +1.0 dB • Wavelength accuracy: +/-25 pm, +/-3.125 GHz • Tuning time: Warm tune – 10 seconds; cold start – 40 seconds • Extinction ratio: ≥ 11 dB • Crossing ratio: 45 to 55 percent • Side-mode suppression ratio: ≥ 30 dB • Optical spectral width: ≤ 25 GHz (informational, not a specification) • Average relative intensity noise (RIN): <ul style="list-style-type: none"> • 10 MHz to 1 GHz: -110 dB/Hz • 1 GHz to 10 GHz: -145 dB/Hz • Output OSNR: <ul style="list-style-type: none"> • Minimum: 50 dB (0.1 nm resolution bandwidth) • Typical: 55 dB (0.1 nm resolution bandwidth) • Polarization extinction ratio: 20 dB • Eye mask compliance: 802.3—2005 • Jitter generation compliance: GR-253/G.8251
Optical receiver	<ul style="list-style-type: none"> • Receiver type: Avalanche photodiode (APD) • Average receive power (input power range): see Input Power Range in Table 38 on page 64 • Jitter tolerance compliance: GR-253/G.8251/802.3ae (LAN PHY) • Rx DTV setting: <ul style="list-style-type: none"> • No FEC (pass-through): Static (factory optimized value) • GFEC: Managed by electronic dispersion compensation (EDC) • EFEC: Managed by EDC • Rx wavelength range: 1527 to 1567 nm • Overload (receiver saturation): -5 dBm (high OSNR), -8 dBm (low OSNR) • Damage input power: +5 dBm • Optical return loss: ≥ 27 dB

Table 36: 10-Gigabit Ethernet DWDM OTN Optical Interface Specifications (continued)

Optical performance	<p>Optical Applications—Power-Limited Receiver (High OSNR):</p> <ul style="list-style-type: none"> • Sensitivity: <ul style="list-style-type: none"> • No FEC: -5 to -24 dBm (>33 dB/0.1 nm OSNR, 0 ps/nm CD) at 10^{-12} BER (10.3 Gbps) • GFEC: -5 to -28 dBm at 8×10^{-5} pre-FEC BER (>33 dB/0.1 nm OSNR, 0 ps/nm CD) (10^{-15} post-FEC BER) (11.05 and 11.1 Gbps) • EFEC: -5 to -28 dBm at 1×10^{-3} pre-FEC BER (>33 dB/0.1 nm OSNR, 0 ps/nm CD) (10^{-15} post-FEC BER) (11.05 and 11.1 Gbps) • Chromatic dispersion (CD) power penalty: <ul style="list-style-type: none"> • No FEC: 3 dB (typical penalty at +/-1200 ps/nm without EDC) • GFEC or EFEC: 3 dB (typical penalty at +/-1600 ps/nm with EDC) <p>Optical Applications—Noise-Limited Receiver (Low OSNR):</p> <ul style="list-style-type: none"> • Required OSNR: <ul style="list-style-type: none"> • No FEC (10.3 Gbps): <ul style="list-style-type: none"> • 26 dB/0.1 nm (-8 to -20 dBm Rx input power range, 0 ps/nm CD, at 10^{-12} BER) • 26 dB/0.1 nm (-8 to -20 dBm Rx input power range, +/-1000 ps/nm without EDC, at 10^{-12} BER) • 30 dB/0.1 nm (-8 to -20 dBm Rx input power range, +/-1200 ps/nm without EDC, at 10^{-12} BER) • GFEC (11.05 and 11.1 Gbps): <ul style="list-style-type: none"> • 15.5 dB/0.1 nm (-8 to -20 dBm Rx input power range, 0 ps/nm, at $\leq 10^{-5}$ pre-FEC BER, $\leq 10^{-15}$ post-FEC BER) • 17 dB/0.1 nm (-8 to -20 dBm Rx input power range, +/-1200 ps/nm with EDC, at $\leq 10^{-5}$ pre-FEC BER, $\leq 10^{-15}$ post-FEC BER) • EFEC (11.05 and 11.1 Gbps): <ul style="list-style-type: none"> • 12 dB/0.1 nm (-8 to -20 dBm Rx input power range, 0 ps/nm, at $\leq 10^{-4}$ pre-FEC BER, $\leq 10^{-15}$ post-FEC BER) • 14 dB/0.1 nm (-8 to -20 dBm Rx input power range, +/-1200 ps/nm with EDC, at $\leq 10^{-4}$ pre-FEC BER, $\leq 10^{-15}$ post-FEC BER) • 16 dB/0.1 nm (-8 to -20 dBm Rx input power range, 0 ps/nm CD, 10^{-15} post-FEC BER) • CD OSNR penalty: <ul style="list-style-type: none"> • GFEC: 1.5 dB (typical penalty at +/-1200 ps/nm with Rx input power range from -8 to -20 dBm). • EFEC: 2 dB (typical penalty at +/-1200 ps/nm with Rx input power range from -8 to -20 dBm). <p>For more detailed information, see Table 38 on page 64.</p>
---------------------	---

10-Gigabit Ethernet DWDM OTN Supported Wavelengths

[Table 37 on page 63](#) provides the supported wavelengths for the 100-GHz grid and the 50-GHz offset in both THz and nm.

Table 37: 10-Gigabit Ethernet DWDM OTN Supported Wavelengths

100-GHz Grid		50-GHz Offset		100-GHz Grid		50-GHz Offset	
THz	nm	THz	nm	THz	nm	THz	nm
191.70	1563.86	191.75	1563.45	194.00	1545.32	194.05	1544.92
191.80	1563.04	191.85	1562.63	194.10	1544.52	194.15	1544.12
191.90	1562.23	191.95	1561.82	194.20	1543.73	194.25	1543.33
192.00	1561.41	192.05	1561.01	194.30	1542.93	194.35	1542.53
192.10	1560.60	192.15	1560.20	194.40	1542.14	194.45	1541.74
192.20	1559.79	192.25	1559.38	194.50	1541.34	194.55	1540.95
192.30	1558.98	192.35	1558.57	194.60	1540.55	194.65	1540.16
192.40	1558.17	192.45	1557.76	194.70	1539.76	194.75	1539.37
192.50	1557.36	192.55	1556.95	194.80	1538.97	194.85	1538.58
192.60	1556.55	192.65	1556.15	194.90	1538.18	194.95	1537.79
192.70	1555.74	192.75	1555.34	195.00	1537.39	195.05	1537.00
192.80	1554.94	192.85	1554.53	195.10	1536.60	195.15	1536.21
192.90	1554.13	192.95	1553.73	195.20	1535.82	195.25	1535.42
193.00	1553.32	193.05	1552.92	195.30	1535.03	195.35	1534.64
193.10	1552.52	193.15	1552.12	195.40	1534.25	195.45	1533.85
193.20	1551.72	193.25	1551.31	195.50	1533.46	195.55	1533.07
193.30	1550.91	193.35	1550.51	195.60	1532.68	195.65	1532.28
193.40	1550.11	193.45	1549.71	195.70	1531.89	195.75	1531.50
193.50	1549.31	193.55	1548.91	195.80	1531.11	195.85	1530.72
193.60	1548.51	193.65	1548.11	195.90	1530.33	195.95	1529.94
193.70	1547.71	193.75	1547.31	196.00	1529.55	196.05	1529.16
193.80	1546.91	193.85	1546.51	196.10	1528.77		
193.90	1546.11	193.95	1545.72				

PC-1XGE-DWDM-OTN Optical Signal-to-Noise Ratio (OSNR) Performance

The OSNR performance listed in [Table 38 on page 64](#) is for an appropriate level of optical filtering of the amplified spontaneous emission (ASE) reaching the receiver and is derived using a 0.22-nm 3-dB full-width Gaussian filter. When no FEC is used, there is no OTN framing.

Table 38: PC-1XGE-DWDM-OTN Optical Signal-to-Noise Ratio (OSNR) Performance

OSNR (dB/0.1 nm)	OSNR (dB/0.5 nm)	FEC Type	Pre-FEC BER	Post-FEC BER	Input-Power Range (ROP) (dBm)	CD Tolerance (ps/nm)
33	26	None	10^{-12}	NA	-5 to -24	0
33	26	None	10^{-12}	NA	-5 to -21	+/-1200 (no EDC)
26	19	None	10^{-12}	NA	-8 to -22	0
26	19	None	10^{-12}	NA	-8 to -20	+/-1000 (no EDC)
30	23	None	10^{-12}	NA	-8 to -20	+/-1200 (no EDC)
33	26	GFEC	8×10^{-5}	10^{-15}	-5 to -28	0
33	26	GFEC	8×10^{-5}	10^{-15}	-5 to -25	+/-1600 (with EDC)
15.5	8.5	GFEC	10^{-5}	10^{-15}	-8 to -20	0
17	10	GFEC	10^{-5}	10^{-15}	-8 to -20	+/-1200 (with EDC)
33	26	EFEC	10^{-3}	10^{-15}	-5 to -28	0
33	26	EFEC	10^{-3}	10^{-15}	-5 to -25	+/-1600 (with EDC)
12	5	EFEC	7×10^{-4}	10^{-15}	-8 to -20	0
14	7	EFEC	7×10^{-4}	10^{-15}	-8 to -20	+/-1200 (with EDC)

Related Documentation

- [Supported Network Interface Standards by Transceiver for ACX Series, M Series, MX Series, and T Series Routers on page 33](#)

40-Gigabit Ethernet 40GBASE-R Optical Interface Specifications

The 40-Gigabit Ethernet optical interface standards are supported on MX2020, MX2010, MX960, MX480, MX240, PTX Series, T640, T1600, and T4000 routers.

To determine which transceivers support each 40GBASE-R standard, see [“Supported Network Interface Standards by Transceiver for ACX Series, M Series, MX Series, and T Series Routers”](#) on page 33 and [Supported Network Interface Standards by Transceiver for PTX Series Routers](#). The “Cables and Connectors” section in the description for each MIC or PIC lists which standards and transceivers are supported for that device.

The specifications are organized by distance supported.

- [40GBASE-SR4 Specifications on page 65](#)
- [40GBASE-LX4 Specifications on page 65](#)
- [40GBASE-LR4 Specifications on page 66](#)
- [40GBASE-ER4 Specifications on page 67](#)

40GBASE-SR4 Specifications

[Table 39 on page 65](#) shows the optical interface specifications for the 40GBASE-SR4 standard.

Table 39: 40GBASE-SR4 Optical Interface Specifications

Parameter	40GBASE-SR4
Optical interface	Multimode
Standard	IEEE 802.3ba-2010
Maximum distance	OM3 MMF cable, 100 m (328 ft) OM4 MMF cable, 150 m (492 ft)
Transmitter wavelength per lane	840 through 860 nm
Average launch power per lane	-7.6 through 2.4 dBm
Average receive power per lane	-9.5 through 2.4 dBm
Stressed receiver sensitivity (OMA) per lane (maximum)	-5.4 dBm

40GBASE-LX4 Specifications

[Table 40 on page 65](#) shows the optical interface specifications for the Juniper Networks proprietary 40GBASE-LX4.

Table 40: 40GBASE-LX4 Optical Interface Specifications

Parameter	40GBASE-LX4
Signaling rate, each lane (range)	10.3125 GBd +/-100 ppm
Connector type	Dual LC/PC

Table 40: 40GBASE-LX4 Optical Interface Specifications (*continued*)

Parameter	40GBASE-LX4			
Fiber pairs	1			
Transmit and receive lane wavelengths	Lane 0–1264.5 nm through 1277.5 nm			
	Lane 1–1284.5 nm through 1297.5 nm			
	Lane 2–1304.5 nm through 1317.5 nm			
	Lane 3–1324.5 nm through 1337.5 nm			
Average transmit launch power, each lane (minimum)	SMF	-9.0 dBm		
	MMF	-7.0 dBm		
Average transmit launch power, each lane (maximum)	SMF	2.3 dBm		
	MMF	4.3 dBm		
Average receive power, each lane (minimum)	SMF	-12 dBm		
	MMF	-10.0 dBm		
Average receive power, each lane (maximum)	SMF	2.3 dBm		
	MMF	4.3 dBm		
Receiver sensitivity (OMA), each lane (maximum)	SMF	-10.5 dBm		
	MMF	-10.5 dBm		
Fiber type	SMF	MMF	MMF	
	Core/cladding size	9/125 μ m	50/125 μ m	50/125 μ m
	Fiber grade	OS1	OM3	OM4
	Effective modal bandwidth at 850 nm	–	2000 MHz x km	4700 MHz x km
	Operating distance	2 km (1.24 miles)	100 m (328 ft)	150 m (492 ft)

40GBASE-LR4 Specifications

Table 41 on page 67 shows the optical interface specifications for the 40GBASE-LR4 standard.

Table 41: 40GBASE-LR4 Optical Interface Specifications

Parameter	40GBASE-LR4
Optical interface	Single mode
Standard	IEEE 802.3ba-2010
Maximum distance	9/125 SMF cable: 10 km (6.2 miles)
Transmitter wavelength per lane	1264.5 through 1277.5 nm 1284.5 through 1297.5 nm 1304.5 through 1317.5 nm 1324.5 through 1337.5 nm
Average launch power per lane	-7 through 2.3 dBm
Total average launch power (maximum)	8.3 dBm
Average receive power per lane	-13.7 through 2.3 dBm
Receiver sensitivity (OMA) per lane (maximum)	-11.5 dBm

40GBASE-ER4 Specifications

Table 42 on page 67 shows the optical interface specifications for the 40GBASE-ER4 standard.

Table 42: 40GBASE-ER4 Optical Interface Specifications

Parameter	40GBASE-ER4
Optical interface	Single mode
Standard	IEEE 802.3bm-2015
Maximum distance	9/125 SMF cable: 40 km (24.8 miles)
Transmitter wavelength per lane	1264.5 through 1277.5 nm 1284.5 through 1297.5 nm 1304.5 through 1317.5 nm 1324.5 through 1337.5 nm
Average launch power per lane	-2.7 through 4.5 dBm
Total average launch power (maximum)	4.5 dBm

Table 42: 40GBASE-ER4 Optical Interface Specifications (*continued*)

Parameter	40GBASE-ER4
Average receive power per lane	-21.2 through -4.5 dBm
Receiver sensitivity (OMA) per lane (maximum)	-19 dBm

100-Gigabit Ethernet 100GBASE-R Optical Interface Specifications

The 100-Gigabit Ethernet optical interface standards described below are supported on MX Series, PTX Series, T1600, and T4000 routers.



NOTE: The CFP-100GBASE-ZR transceiver is not supported on the T1600 and T4000 routers.

To determine which transceivers support each 100GBASE-R standard, see “[Supported Network Interface Standards by Transceiver for ACX Series, M Series, MX Series, and T Series Routers](#)” on page 33 or [Supported Network Interface Standards by Transceiver for PTX Series Routers](#). The “Cables and Connectors” section in the description for each MIC or PIC lists which standards and transceivers are supported for that device.

The specifications are organized by distance supported.

- [100GBASE-SR10 Specifications on page 68](#)
- [100GBASE-SR4 Specifications on page 69](#)
- [100GBASE-LR4 Specifications on page 69](#)
- [100GBASE-ER4 Specifications on page 70](#)
- [Juniper Networks Specifications for CFP-100GBASE-ZR on page 71](#)

100GBASE-SR10 Specifications

Table 43 on page 68 shows the optical interface specifications for the 100GBASE-SR10 standard.

Table 43: 100GBASE-SR10 Optical Interface Specifications

Parameter	100GBASE-SR10
Optical interface	Multimode
Standard	IEEE 802.3ba—2010
Maximum distance	OM3 MMF cable, 100 m (328 ft) OM4 MMF cable, 150 m (492 ft)
Transmitter wavelength per lane	840 through 860 nm

Table 43: 100GBASE-SR10 Optical Interface Specifications (*continued*)

Parameter	100GBASE-SR10
Average launch power per lane	-7.6 through 2.4 dBm
Average receive power per lane	-9.5 through 2.4 dBm
Stressed receiver sensitivity (OMA) per lane (maximum)	-5.4 dBm

100GBASE-SR4 Specifications

Table 44 on page 69 shows the optical interface specifications for the 100GBASE-SR4 standard.

Table 44: 100GBASE-SR4 Optical Interface Specifications

Parameter	100GBASE-SR4
Optical interface	Multimode
Standard	IEEE 802.3bm
Maximum distance	OM3 MMF cable, 70 m (230 feet) OM4 MMF cable, 100 m (328 feet)
Transmitter wavelength per lane	840 through 860 nm
Average launch power per lane	-8.4 through 2.4 dBm
Average receive power per lane	-10.3 through 2.4 dBm
Stressed receiver sensitivity (OMA), each lane (maximum)	-5.2 dBm

100GBASE-LR4 Specifications

Table 45 on page 69 shows the optical interface specifications for the 100GBASE-LR4 standard.

Table 45: 100GBASE-LR4 Optical Interface Specifications

Parameter	100GBASE-LR4
Optical interface	Single-mode
Standard	IEEE 802.3ba-2010
Maximum distance	9/125 SMF cable, 10 km (6.2 miles)

Table 45: 100GBASE-LR4 Optical Interface Specifications (continued)

Parameter	100GBASE-LR4
Transmitter wavelength per lane	1294.53 through 1296.59 nm
	1299.02 through 1301.09 nm
	1303.54 through 1305.63 nm
	1308.09 through 1310.19 nm
Average launch power per lane	-4.3 through 4.5 dBm
	Total maximum launch is 10.5 dBm.
Average receive power per lane	-10.6 through 4.5 dBm
Receiver sensitivity (OMA) per lane (maximum)	-8.6 dBm

100GBASE-ER4 Specifications

Table 46 on page 70 shows the optical interface specifications for the 100GBASE-ER4 standard.

Table 46: 100GBASE-ER4 Optical Interface Specifications

Parameter	100GBASE-ER4
Optical interface	Single-mode
Standard	IEEE 802.3ba-2010
Maximum distance	SMF cable, 40 km (24.9 miles)
Transmitter wavelength per lane	1294.53 through 1296.59 nm
	1299.02 through 1301.09 nm
	1303.54 through 1305.63 nm
	1308.09 through 1310.19 nm
Average launch power per lane	-2.9 through 2.9 dBm
Average receive power per lane	-20.9 through 4.5 dBm
Receiver sensitivity (OMA) per lane (maximum)	-21.4 dBm

Juniper Networks Specifications for CFP-100GBASE-ZR

The CFP-100GBASE-ZR transceiver is not specified as part of IEEE 802.3 but is built according to Juniper Networks specifications.

[Table 47 on page 71](#) shows the optical interface specifications for the CFP-100GBASE-ZR transceiver.

Table 47: Juniper Networks Optical Interface Specifications for CFP-100GBASE-ZR

Parameter	CFP-100GBASE-ZR
Optical interface	Single-mode
Standard	Proprietary Dual polarization-quadrature phase shift keying (DP-QPSK) with forward error correction (FEC)
Maximum distance	80 km (49.7 miles) Greater reach possible with link engineering
Line rate	120.579 Gbps
Transmitter frequency / wavelength	193.90 THz (+/-1.8 GHz) / 1546.119 nm
Transmit output power (enabled)	+5 dBm
Transmit output power (disabled)	-40 dBm
Receive frequency / wavelength	193.90 THz (+/-1.8 GHz) / 1546.119 nm
Receive input optical power range	-20 through +5 dBm
Receive input optical power damage threshold	+10 dBm
Receive chromatic dispersion (CD) tolerance	+/-2500 ps/nm
Receive polarization mode dispersion (PMD) tolerance	15 ps (mean DGD)
Receive polarization tracking	50 krad/s

Related Documentation

- [Supported Network Interface Standards by Transceiver for ACX Series, M Series, MX Series, and T Series Routers on page 33](#)
- [Supported Network Interface Standards by Transceiver for PTX Series Routers](#)

100-Gigabit DWDM OTN CFP2-ACO Optical Interface Specifications

MX Series routers support a 1-port 100-Gigabit Dense Wavelength Division Multiplexing (DWDM) Optical Transport Network (OTN) MIC with CFP2 (model number MIC3-100G-DWDM). PTX Series routers support a 5-port 100-Gigabit DWDM OTN PIC with CFP2 (model number PTX-5-100G-WDM). MIC3-100G-DWDM and PTX-5-100G-WDM interface cards support a CFP2 analog coherent optics (CFP2-ACO) transceiver (model number TCFP2-100G-C).

Table 48 on page 72 and Table 49 on page 74 show the combined optical interface specifications for the TCFP2-100G-C transceiver and the MIC3-100G-DWDM MIC and PTX-5-100G-WDM PIC.



NOTE: High-gain forward error correction (HG-FEC) is not supported on the PTX-5-100G-WDM PIC.



NOTE: The transceiver complies with the CFP Multi-Source Agreement (MSA) mechanical standard—transceiver weight does not exceed 210 g (7.41 oz).

Table 48: 100-Gigabit DWDM OTN CFP2-ACO Optical Interface Specifications

Parameter	100-Gigabit DWDM OTN CFP2-ACO
Transceiver type	<ul style="list-style-type: none"> CFP2-ACO (model number TCFP2-100G-C)
Standards	<ul style="list-style-type: none"> ITU-T G.709—Interfaces for the optical transport network. ITU-T G.798—Characteristics of optical transport network hierarchy equipment functional blocks ITU-T G.694.1—Spectral grids for WDM applications: DWDM frequency grid RFC 3591—<i>Definitions of Managed Objects for the Optical Interface Type</i>
Optical interface	<ul style="list-style-type: none"> Single-mode optical fiber (ITU-T G.652), duplex LC/UPC connector
Laser safety	IEC 60825-1 Class 1

Table 48: 100-Gigabit DWDM OTN CFP2-ACO Optical Interface Specifications (*continued*)

Parameter	100-Gigabit DWDM OTN CFP2-ACO
Line interface	<ul style="list-style-type: none"> • Line rate <ul style="list-style-type: none"> • Soft-decision FEC (SD-FEC): 120.58 Gbps • High-gain FEC (HG-FEC): 111.81 Gbps • G.709 FEC (GFEC): 111.81 Gbps • Modulation format: Dual-polarization quadrature phase shift keying (DP-QPSK) • FEC types <ul style="list-style-type: none"> • SD-FEC: Soft-decision • HG-FEC: Staircase • GFEC: G.709 • Channel-plan wavelength range: 1568.362 nm through 1528.773 nm • Channel-plan frequency range: 191.15 THz through 196.10 THz • Channel spacing: 50 GHz • Channel tunability: 100 channels—see Table 49 on page 74
Optical transmitter	<ul style="list-style-type: none"> • Output power (on): –8 through 0 dBm • Output power (off): ≤ –45 dBm • Wavelength accuracy: +/-1.8 GHz • Channel tuning time: ≤60 seconds
Optical receiver	<ul style="list-style-type: none"> • Input power range (normal): –18 through 0 dBm • Input power range (extended): –22 through +3 dBm <p style="margin-left: 20px;">NOTE: Extended range has a 0.8 dB optical signal-to-noise ratio (OSNR) penalty versus normal range in SD-FEC mode.</p> • Damage input power threshold: +17 dBm • Input sensitivity (unamplified or dark-fiber applications) <ul style="list-style-type: none"> • SD-FEC: –30.5 dBm • HG-FEC: –28.5 dBm • GFEC: –23.0 dBm • Minimum OSNR (back-to-back), typical <ul style="list-style-type: none"> • SD-FEC: 14.0 dB • HG-FEC: 16.0 dB • GFEC: 24.0 dB • Minimum OSNR (back-to-back), worst-case, EOL <ul style="list-style-type: none"> • SD-FEC: 14.5 dB • HG-FEC: 16.5 dB • GFEC: 25.0 dB • Chromatic dispersion tolerance: +/-40,000 ps/nm • PMD tolerance: 25 ps (mean) • Polarization tracking: 50 krad/s

Table 49 on page 74 provides the supported wavelengths in both terahertz (THz) and nanometers (nm).

Table 49: 100-Gigabit DWDM OTN CFP2-ACO Supported Wavelengths

100-GHz Grid		50-GHz Offset	
THz	nm	THz	nm
–	–	191.15	1568.36
191.20	1567.95	191.25	1567.54
191.30	1567.13	191.35	1566.72
191.40	1566.31	191.45	1565.90
191.50	1565.50	191.55	1565.09
191.60	1564.68	191.65	1564.27
191.70	1563.86	191.75	1563.45
191.80	1563.05	191.85	1562.64
191.90	1562.23	191.95	1561.83
192.00	1561.42	192.05	1561.01
192.10	1560.61	192.15	1560.20
192.20	1559.79	192.25	1559.39
192.30	1558.98	192.35	1558.58
192.40	1558.17	192.45	1557.77
192.50	1557.36	192.55	1556.96
192.60	1556.55	192.65	1556.15
192.70	1555.75	192.75	1555.34
192.80	1554.94	192.85	1554.54
192.90	1554.13	192.95	1553.73
193.00	1553.33	193.05	1552.93
193.10	1552.52	193.15	1552.12

Table 49: 100-Gigabit DWDM OTN CFP2-ACO Supported Wavelengths (*continued*)

100-GHz Grid		50-GHz Offset	
THz	nm	THz	nm
193.20	1551.72	193.25	1551.32
193.30	1550.92	193.35	1550.52
193.40	1550.12	193.45	1549.72
193.50	1549.32	193.55	1548.91
193.60	1548.51	193.65	1548.11
193.70	1547.72	193.75	1547.32
193.80	1546.92	193.85	1546.52
193.90	1546.12	193.95	1545.72
194.00	1545.32	194.05	1544.92
194.10	1544.53	194.15	1544.13
194.20	1543.73	194.25	1543.33
194.30	1542.94	194.35	1542.54
194.40	1542.14	194.45	1541.75
194.50	1541.35	194.55	1540.95
194.60	1540.56	194.65	1540.16
194.70	1539.77	194.75	1539.37
194.80	1538.98	194.85	1538.58
194.90	1538.19	194.95	1537.79
195.00	1537.40	195.05	1537.00
195.10	1536.61	195.15	1536.22
195.20	1535.82	195.25	1535.43
195.30	1535.04	195.35	1534.64
195.40	1534.25	195.45	1533.86

Table 49: 100-Gigabit DWDM OTN CFP2-ACO Supported Wavelengths (*continued*)

100-GHz Grid		50-GHz Offset	
THz	nm	THz	nm
195.50	1533.47	195.55	1533.07
195.60	1532.68	195.65	1532.29
195.70	1531.90	195.75	1531.51
195.80	1531.12	195.85	1530.72
195.90	1530.33	195.95	1529.94
196.00	1529.55	196.05	1529.16
196.10	1528.77	–	–

- Related Documentation**
- [100-Gigabit DWDM OTN MIC with CFP2-ACO on page 223](#)
 - [100-Gigabit DWDM OTN PIC with CFP2 \(PTX Series\)](#)
 - [Supported Network Interface Standards by Transceiver for ACX Series, M Series, MX Series, and T Series Routers on page 33](#)
 - [Supported Network Interface Standards by Transceiver for PTX Series Routers](#)

SONET/SDH OC3/STM1 Optical Interface Specifications

The SONET/SDH OC3/STM1 standards are supported on M Series routers, MX Series routers, and T Series routers.

To determine which transceivers support each SONET/SDH OC3/STM1 standard, see “Supported Network Interface Standards by Transceiver for ACX Series, M Series, MX Series, and T Series Routers” on page 33. The “Cables and connectors” section in the description for each MIC or PIC lists which standards and transceivers are supported for that device.

The specifications are organized by distance supported.

- [SONET/SDH OC3/STM1 Specifications on page 76](#)
- [SONET/SDH OC3/STM1 Intermediate Reach \(IR-1\) Specifications on page 77](#)
- [SONET/SDH OC3/STM1 Long Reach \(LR-1\) Specifications on page 77](#)

SONET/SDH OC3/STM1 Specifications

Table 50 on page 77 shows the multimode SONET/SDH OC3/STM1 optical interface specifications.

Table 50: SONET/SDH OC3/STM1 Multimode Optical Interface Specifications

Parameter	Multimode
Optical interface	Multimode
Maximum distance	MMF cable: 1.2 miles (2 km)
Standard	Multivendor agreement
Transmitter wavelength	1270 through 1380 nm
Average launch power	-20 through -14 dBm
Receiver saturation	-14 dBm
Receiver sensitivity	-30 dBm

SONET/SDH OC3/STM1 Intermediate Reach (IR-1) Specifications

Table 51 on page 77 shows the SONET/SDH OC3/STM1 intermediate reach (IR-1) optical interface specifications.

Table 51: SONET/SDH OC3/STM1 Intermediate Reach Optical Interface Specifications

Parameter	Intermediate Reach (IR-1)
Optical interface	Single-mode
Maximum distance	SMF cable: 9.3 miles (15 km)
Standard	Telcordia GR-253
Transmitter wavelength	1261 through 1360 nm
Average launch power	-15 through -8 dBm
Receiver saturation	-8 dBm
Receiver sensitivity	-28 dBm

SONET/SDH OC3/STM1 Long Reach (LR-1) Specifications

Table 52 on page 78 shows the SONET/SDH OC3/STM1 long reach (LR-1) optical interface specifications.

Table 52: SONET/SDH OC3/STM1 Long Reach -1 Optical Interface Specifications

Parameter	Long Reach (LR-1)
Optical interface	Single-mode
Maximum distance	SMF cable: 24.85 miles (40 km)
Standard	Telcordia GR-253
Transmitter wavelength	1263 through 1360 nm
Average launch power	-5 through 0 dBm
Receiver saturation	-10 dBm
Receiver sensitivity	-34 dBm

Related Documentation

- [Supported Network Interface Standards by Transceiver for ACX Series, M Series, MX Series, and T Series Routers on page 33](#)

SONET/SDH OC12/STM4 Optical Interface Specifications

The SONET/SDH OC12/STM4 optical interface standards are supported on M Series routers, MX Series routers, and T Series routers.

To determine which transceivers support each SONET/SDH OC12/STM4 standard, see “Supported Network Interface Standards by Transceiver for ACX Series, M Series, MX Series, and T Series Routers” on page 33. The “Cables and connectors” section in the description for each MIC or PIC lists which standards and transceivers are supported for that device.

The specifications are organized by distance supported.

- [SONET/SDH OC12/STM4 Short Reach \(SR-1\) Specifications on page 78](#)
- [SONET/SDH OC12/STM4 Intermediate Reach \(IR-1\) Specifications on page 79](#)
- [SONET/SDH OC12/STM4 Long Reach \(LR-1\) Specifications on page 79](#)
- [SONET/SDH OC12/STM4 Long Reach \(LR-2\) Specifications on page 80](#)

SONET/SDH OC12/STM4 Short Reach (SR-1) Specifications

[Table 53 on page 79](#) shows the SONET/SDH OC12/STM4 short reach (SR-1) optical interface specifications.

Table 53: SONET/SDH OC12/STM4 Short Reach (SR-1) Optical Interface Specifications

Parameter	Short Reach (SR-1)
Optical interface	Single-mode
Maximum distance	SMF cable: 1.24 miles (2 km)
Standard	Telcordia GR-253
Transmitter wavelength	1261 through 1360 nm
Average launch power	-15 through -8 dBm
Receiver saturation	-8 dBm
Receiver sensitivity	-23 dBm

SONET/SDH OC12/STM4 Intermediate Reach (IR-1) Specifications

Table 54 on page 79 shows the SONET/SDH OC12/STM4 short reach (IR-1) optical interface specifications.

Table 54: SONET/SDH OC12/STM4 Intermediate Reach (IR-1) Optical Interface Specifications

Parameter	Intermediate Reach (IR-1)
Optical interface	Single-mode
Maximum distance	SMF cable: 9.3 miles (15 km)
Standard	Telcordia GR-253
Transmitter wavelength	1274 through 1356 nm
Average launch power	-15 through -8 dBm
Receiver saturation	-8 dBm
Receiver sensitivity	-28 dBm

SONET/SDH OC12/STM4 Long Reach (LR-1) Specifications

Table 55 on page 80 shows the SONET/SDH OC12/STM4 short reach (LR-1) optical interface specifications.

Table 55: SONET/SDH OC12/STM4 Long Reach (LR-1) Optical Interface Specifications

Parameter	Long Reach (LR-1)
Optical interface	Single-mode
Maximum distance	SMF cable: 24.85 miles (40 km)
Standard	Telcordia GR-253
Transmitter wavelength	1280 through 1335 nm
Average launch power	-3 through +2 dBm
Receiver saturation	-8 dBm
Receiver sensitivity	-28 dBm

SONET/SDH OC12/STM4 Long Reach (LR-2) Specifications

Table 56 on page 80 shows the SONET/SDH OC12/STM4 short reach (LR-2) optical interface specifications.

Table 56: SONET/SDH OC12/STM4 Long Reach (LR-2) Optical Interface Specifications

Parameter	Long Reach (LR-2)
Optical interface	Single-mode
Maximum distance	SMF cable: 49.70 miles (80 km)
Standard	Telcordia GR-253
Transmitter wavelength	1480 through 1580 nm
Average launch power	-3 through 2 dBm
Receiver saturation	-8 dBm
Receiver sensitivity	-28 through -8 dBm

Related Documentation

- [Supported Network Interface Standards by Transceiver for ACX Series, M Series, MX Series, and T Series Routers on page 33](#)

SONET/SDH OC48/STM16 Optical Interface Specifications

The SONET/SDH OC48/STM16 standards are supported on M40e routers, M120 routers, M320 routers, MX Series routers, and T Series routers.

To determine which transceivers support each SONET/SDH OC48/STM16 standard, see “Supported Network Interface Standards by Transceiver for ACX Series, M Series, MX Series, and T Series Routers” on page 33. The “Cables and connectors” section in the description for each MIC or PIC lists which standards and transceivers are supported for that device.

The specifications are organized by distance supported.

- [SONET/SDH OC48/STM16 Short Reach \(SR-1\) Specifications on page 81](#)
- [SONET/SDH OC48/STM16 Intermediate Reach \(IR-1\) Specifications on page 81](#)
- [SONET/SDH OC48/STM16 Long Reach \(LR-1\) Specifications on page 82](#)
- [SONET/SDH OC48/STM16 Long Reach \(LR-2\) Specifications on page 82](#)

SONET/SDH OC48/STM16 Short Reach (SR-1) Specifications

[Table 57 on page 81](#) shows the SONET/SDH OC48/STM16 short reach (SR-1) optical interface specifications.

Table 57: SONET/SDH OC48/STM16 Short Reach (SR-1) Optical Interface Specifications

Parameter	Short Reach (SR-1)
Optical interface	Single-mode
Maximum distance	SMF cable: 1.24 miles (2 km)
Standard	Telcordia GR-253
Transmitter wavelength	1266 through 1360 nm
Average launch power	-10 through -3 dBm
Receiver saturation	-3 dBm
Receiver sensitivity	-18 dBm

SONET/SDH OC48/STM16 Intermediate Reach (IR-1) Specifications

[Table 58 on page 81](#) shows the SONET/SDH OC48/STM16 intermediate reach (IR-1) optical interface specifications.

Table 58: SONET/SDH OC48/STM16 Intermediate Reach (IR-1) Optical Interface Specifications

Parameter	Intermediate Reach (IR-1)
Optical interface	Single-mode
Maximum distance	SMF cable: 9.3 miles (15 km)

Table 58: SONET/SDH OC48/STM16 Intermediate Reach (IR-1) Optical Interface Specifications (continued)

Parameter	Intermediate Reach (IR-1)
Standard	Telcordia GR-253
Transmitter wavelength	1260 through 1360 nm
Average launch power	-5 through 0 dBm
Receiver saturation	0 dBm
Receiver sensitivity	-18 dBm

SONET/SDH OC48/STM16 Long Reach (LR-1) Specifications

Table 59 on page 82 shows the SONET/SDH OC48/STM16 long reach (LR-1) optical interface specifications.

Table 59: SONET/SDH OC48/STM16 Long Reach (LR-1) Optical Interface Specifications

Parameter	Long Reach (LR-1)
Optical interface	Single-mode
Maximum distance	SMF cable: 28.85 miles (40 km)
Standard	Telcordia GR-253
Transmitter wavelength	1280 through 1335 nm
Average launch power	-2 through +3 dBm
Receiver saturation	-9 dBm
Receiver sensitivity	-28 dBm

SONET/SDH OC48/STM16 Long Reach (LR-2) Specifications

Table 60 on page 82 shows the SONET/SDH OC48/STM16 long reach (LR-2) optical interface specifications.

Table 60: SONET/SDH OC48/STM16 Long Reach (LR-2) Optical Interface Specifications

Parameter	Long Reach (LR-2)
Optical interface	Single-mode
Maximum distance	SMF cable: 49.71 miles (80 km)

Table 60: SONET/SDH OC48/STM16 Long Reach (LR-2) Optical Interface Specifications (continued)

Parameter	Long Reach (LR-2)
Standard	Telcordia GR-253
Transmitter wavelength	1500 through 1580 nm
Average launch power	-2 through +3 dBm
Receiver saturation	-9 dBm
Receiver sensitivity	-28 dBm

Related Documentation

- [Supported Network Interface Standards by Transceiver for ACX Series, M Series, MX Series, and T Series Routers on page 33](#)

SONET/SDH OC192/STM64 Optical Interface Specifications

The SONET/SDH OC192/STM64 standards are supported on M120 routers, M320 routers, MX Series routers, and T Series routers.

To determine which transceivers support the SONET/SDH OC192/STM64 standard, see “Supported Network Interface Standards by Transceiver for ACX Series, M Series, MX Series, and T Series Routers” on page 33. The “Cables and connectors” section in the description for each MIC or PIC lists which standards and transceivers are supported for that device.

The specifications are organized by distance supported.

- [SONET/SDH OC192/STM64 Very Short Reach \(VSR\) on page 83](#)
- [SONET/SDH OC192/STM64 Short Reach \(SR-1\) on page 84](#)
- [SONET/SDH OC192/STM64 Short Reach \(SR-2\) on page 84](#)
- [SONET/SDH OC192/STM64 Intermediate Reach \(IR-2\) on page 85](#)
- [SONET/SDH OC192/STM64 Long reach \(LR-1\) on page 85](#)
- [SONET/SDH OC192/STM64 Long reach \(LR-2\) on page 86](#)

SONET/SDH OC192/STM64 Very Short Reach (VSR)

Table 61 on page 83 shows the SONET/SDH OC192/STM64 very short reach (VSR) optical interface specifications.

Table 61: SONET/SDH OC192/STM64 Very Short Reach (VSR 1) Optical Interface Specifications

Parameter	Very Short Reach (VSR)
Optical interface	Multimode

Table 61: SONET/SDH OC192/STM64 Very Short Reach (VSR 1) Optical Interface Specifications (continued)

Parameter	Very Short Reach (VSR)
Maximum distance	MMF cable: 984.25 feet (300 m)
Standard	OIF VSR4-1
Transmitter wavelength	830 through 860 nm
Average launch power	-10 through -3 dBm
Receiver saturation	-3 dBm
Receiver sensitivity	-16 dBm

SONET/SDH OC192/STM64 Short Reach (SR-1)

Table 62 on page 84 shows the SONET/SDH OC192/STM64 short reach (SR-1) optical interface specifications.

Table 62: SONET/SDH OC192/STM64 Short Reach (SR-1) Optical Interface Specifications

Parameter	Short Reach (SR-1)
Optical interface	Single-mode
Maximum distance	SMF cable: 6.21 miles (10 km)
Standard	Telcordia GR-253 OC192 SR1
Transmitter wavelength	1290 nm through 1330 nm
Average launch power	-6 through -1 dBm
Receiver saturation	-1.0 dBm
Receiver sensitivity	-11 dBm

SONET/SDH OC192/STM64 Short Reach (SR-2)

Table 63 on page 84 shows the SONET/SDH OC192/STM64 short reach (SR-2) optical interface specifications.

Table 63: SONET/SDH OC192/STM64 Short Reach (SR-2) Optical Interface Specifications

Parameter	Short Reach (SR-2)
Optical interface	Single-mode

Table 63: SONET/SDH OC192/STM64 Short Reach (SR-2) Optical Interface Specifications (continued)

Parameter	Short Reach (SR-2)
Maximum distance	SMF cable: 15.5 miles (25 km)
Standard	Telcordia GR-253 OC192 SR2
Transmitter wavelength	1530 through 1565 nm
Average launch power	-4 through 0 dBm
Receiver saturation	-3 dBm
Receiver sensitivity	-14 dBm

SONET/SDH OC192/STM64 Intermediate Reach (IR-2)

Table 64 on page 85 shows the SONET/SDH OC192/STM64 Intermediate reach (IR-2) optical interface specifications.

Table 64: SONET/SDH OC192/STM64 Intermediate Reach (IR-2) Optical Interface Specifications

Parameter	Intermediate Reach (IR-2)
Optical interface	Single-mode
Maximum distance	SMF cable: 24.8 miles (40 km) <i>NOTE:</i> Distances greater than 30 km are considered to be engineered links.
Standard	Telcordia GR-253 OC192 IR2
Transmitter wavelength	1530 nm through 1565 nm
Average launch power	-1.0. through 2 dBm
Receiver saturation	-1.0 dBm
Receiver sensitivity	-14 dBm

SONET/SDH OC192/STM64 Long reach (LR-1)

Table 65 on page 86 shows the SONET/SDH OC192/STM64 long reach (LR-1) optical interface specifications.

Table 65: SONET/SDH OC192/STM64 Long Reach (LR-1) Optical Interface Specifications

Parameter	Long Reach (LR-1)
Optical interface	Single-mode
Maximum distance	SMF cable: 49.71 miles (80 km)
Standard	Telcordia GR-253 OC192 LR2
Transmitter wavelength	1530 nm through 1565 nm
Average launch power	6 through 8 dBm
Receiver saturation	-10 dBm
Receiver sensitivity	-22 dBm

SONET/SDH OC192/STM64 Long reach (LR-2)

Table 66 on page 86 shows the SONET/SDH OC192/STM64 long reach (LR-2) optical interface specifications.

Table 66: SONET/SDH OC192/STM64 Long Reach (LR-2) Optical Interface Specifications

Parameter	Long Reach (LR-2)
Optical interface	Single-mode
Maximum distance	SMF cable: 49.71 miles (80 km)
Standard	Telcordia GR-253 OC192 LR2
Transmitter wavelength	1530 nm through 1565 nm
Average launch power	0 through 4 dBm
Receiver saturation	-7 dBm
Receiver sensitivity	-24 dBm

Related Documentation

- [Supported Network Interface Standards by Transceiver for ACX Series, M Series, MX Series, and T Series Routers on page 33](#)

PART 2

DPC, MPC, MIC, and PIC Descriptions

- [MX Series DPC Descriptions on page 89](#)
- [MX Series MPC Descriptions on page 133](#)
- [MX Series MIC Descriptions on page 191](#)
- [MX Series PIC Descriptions on page 261](#)

CHAPTER 7

MX Series DPC Descriptions

- Gigabit Ethernet DPC with SFP on page 90
- Gigabit Ethernet Enhanced DPC with SFP on page 92
- Gigabit Ethernet Enhanced Ethernet Services DPC with SFP on page 95
- Gigabit Ethernet Enhanced Queuing Ethernet Services DPC with SFP on page 98
- Gigabit Ethernet Enhanced Queuing IP Services DPCs with SFP on page 101
- 10-Gigabit Ethernet DPC with XFP on page 104
- 10-Gigabit Ethernet Enhanced DPCs with XFP on page 106
- 10-Gigabit Ethernet Enhanced Ethernet Services DPC with XFP on page 108
- 10-Gigabit Ethernet Enhanced Queuing Ethernet Services DPC with XFP on page 110
- 10-Gigabit Ethernet Enhanced Queuing IP Services DPC with XFP on page 112
- Multi-Rate Ethernet Enhanced DPC with SFP and XFP on page 114
- Multi-Rate Ethernet Enhanced Ethernet Services DPC with SFP and XFP on page 118
- Multi-Rate Ethernet Enhanced Queuing IP Services DPC with SFP and XFP on page 122
- Multiservices DPC on page 126
- Tri-Rate Enhanced DPC on page 128
- Tri-Rate Enhanced Ethernet Services DPC on page 130

Gigabit Ethernet DPC with SFP

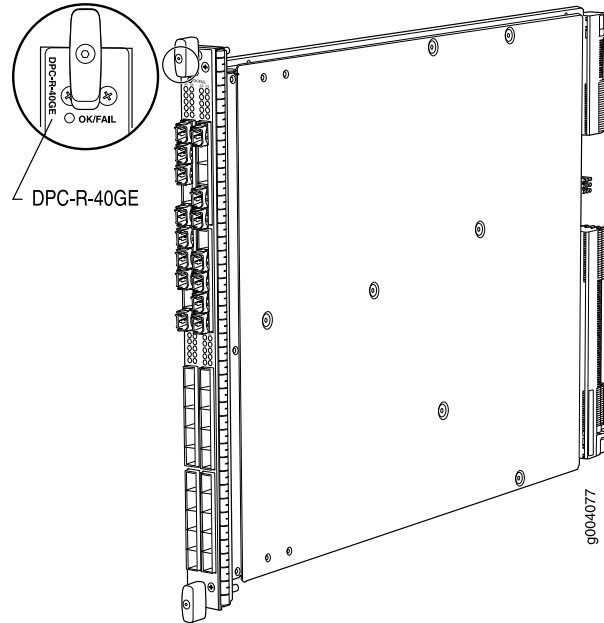

Software release	<ul style="list-style-type: none"> Junos OS Release 8.2 and later End-of-life (see notification PSN-2009-06-400)
Description	<ul style="list-style-type: none"> 40 Gigabit Ethernet ports Power requirement: 6.98 A @ 48 V (335 W) Weight: 13.1 lb (5.9 kg) Supports large Ethernet frame sizes for more efficient throughput across the intra-POP network Model number: DPC-R-40GE-SFP Name in the CLI: DPC 40x 1GE R
Hardware features	<ul style="list-style-type: none"> High-performance throughput on each port at speeds up to 1 Gbps Autonegotiation between Gigabit Ethernet circuit partners Full-duplex mode Maximum transmission units (MTUs) of up to 9192 bytes
Software features	<ul style="list-style-type: none"> Optical diagnostics and related alarms See “Protocols and Applications Supported by DPCs and Enhanced DPCs (DPC and DPCE-R)” on page 297 for information about the protocols and applications that this DPC supports.
Interfaces	<p>Syntax: <i>ge-fpc/pic/port</i> where:</p> <ul style="list-style-type: none"> fpc: Slot in the router where the DPC is installed pic: 0 (bottom left row of 10 ports), 1 (bottom right row of 10 ports), 2 (top left row of 10 ports), or 3 (top right row of 10 ports) port: 0 through 9 <p>For example, <i>ge-1/3/0</i> is the interface for port 0 in the top right row of 10 ports on a DPC installed in slot 1.</p>

Cables and connectors	<ul style="list-style-type: none"> • You can install any transceiver supported by the DPC. For information about installing and removing transceivers, see the hardware guide for your router. • Fiber-optic small form-factor pluggable (SFP) transceivers: <ul style="list-style-type: none"> • Connector: Duplex LC/PC (Rx and Tx) • 1000BASE-EX (model number: SFP-GE40KM) • 1000BASE-LH (model number: SFP-1GE-LH) • 1000BASE-LX (model number: SFP-1GE-LX) • 1000BASE-SX (model number: SFP-1GE-SX) <p>Optical interface specifications—see “Gigabit Ethernet 1000BASE Optical Interface Specifications” on page 44</p> • Copper SFP transceivers: <ul style="list-style-type: none"> • Connector: Four-pair, Category 5 shielded twisted-pair connectivity through an RJ-45 connector • 1000BASE-T (model number: SFP-1GE-T) • Pinout: MDI crossover • Length: 328 ft/100 m <p>Copper interface specifications—see “Gigabit Ethernet 1000BASE-T Copper Interface Specifications” on page 47</p> • Bidirectional SFP transceivers: <ul style="list-style-type: none"> • Connector: Duplex LC/PC (Rx and Tx) • 1000BASE-BX (model number pairs: SFP-GE10KT13R14 with SFP-GE10KT14R13, SFP-GE10KT13R15 with SFP-GE10KT15R13, SFP-GE40KT13R15 with SFP-GE40KT15R13) <p>Optical interface specifications—see “Fast Ethernet and Gigabit Ethernet Bidirectional SFP Optical Interface Specifications” on page 50</p> <p>NOTE: Do not install Gigabit Ethernet SFPs in the SONET/SDH port. The port will not recognize the SFP.</p>
-----------------------	--

LEDs	<p>OK/FAIL LED, one bicolor:</p> <ul style="list-style-type: none"> • Steady green—DPC is functioning normally. • Blinking green—DPC is transitioning online or offline. • Red—DPC has failed. <p>Link LED, one green per port:</p> <ul style="list-style-type: none"> • Off—No link. • On steadily—Link is active. <p>The Link LEDs are labeled in groups of five:</p> <ul style="list-style-type: none"> • 0/0 for 0/0 through 0/4 • 0/5 for 0/5 through 0/9 • 1/0 for 1/0 through 1/4 • 1/5 for 1/5 through 1/9 • 2/0 for 2/0 through 2/4 • 2/5 for 2/5 through 2/9 • 3/0 for 3/0 through 3/4 • 3/5 for 3/5 through 3/9
------	---

Related Documentation

- [MX Series DPC Overview on page 7](#)

- [DPCs Supported on MX240, MX480, and MX960 Routers on page 7](#)
- [Gigabit Ethernet 1000BASE Optical Interface Specifications on page 44](#)
- [Fast Ethernet and Gigabit Ethernet Bidirectional SFP Optical Interface Specifications on page 50](#)

Gigabit Ethernet Enhanced DPC with SFP

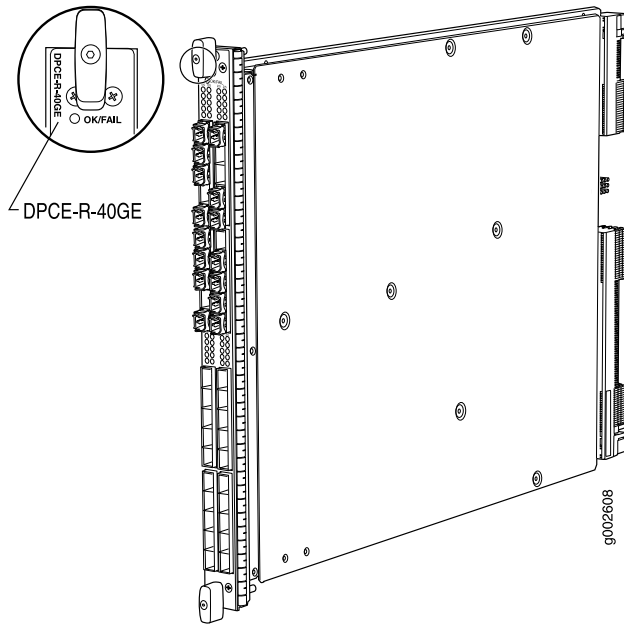

Software release	<ul style="list-style-type: none"> • Junos OS Release 8.4 and later
Description	<ul style="list-style-type: none"> • 40 Gigabit Ethernet ports • Power requirement: 6.98 A @ 48 V (335 W) • Weight: 13.1 lb (5.9 kg) • Supports large Ethernet frame sizes for more efficient throughput across the intra-POP network • Model number: DPCE-R-40GE-SFP • Name in the CLI: DPCE 40x 1GE R
Hardware features	<ul style="list-style-type: none"> • High-performance throughput on each port at speeds up to 1 Gbps • Autonegotiation between Gigabit Ethernet circuit partners • Full-duplex mode • Maximum transmission units (MTUs) of up to 9192 bytes • Enhanced ASICs for increased performance and scalability of Layer 2 features
Software features	<ul style="list-style-type: none"> • Optical diagnostics and related alarms • See “Protocols and Applications Supported by DPCs and Enhanced DPCs (DPC and DPCE-R)” on page 297 for information about the protocols and applications that this DPC supports.

Interfaces

Syntax: *ge-fpc/pic/port* where:

- fpc: Slot in the router where the DPC is installed
- pic: 0 (bottom left row of 10 ports), 1 (bottom right row of 10 ports), 2 (top left row of 10 ports), or 3 (top right row of 10 ports) when installed horizontally
- port: 0 through 9

For example, *ge-1/3/0* is the interface for port 0 in the top right row of 10 ports on a DPC installed in slot 1.

For information on the interface numbering, see the *DPC Port and Interface Numbering* topic for the respective MX router.

Cables and connectors

- You can install any transceiver supported by the DPC. For information about installing and removing transceivers, see the hardware guide for your router.
- Fiber-optic small form-factor pluggable (SFP) transceivers:
 - Connector: Duplex LC/PC (Rx and Tx)
 - 1000BASE-EX (model number: SFP-GE40KM)
 - 1000BASE-LH (model number: SFP-1GE-LH)
 - 1000BASE-LX (model number: SFP-1GE-LX)
 - 1000BASE-SX (model number: SFP-1GE-SX)

Optical interface specifications—see [“Gigabit Ethernet 1000BASE Optical Interface Specifications” on page 44](#)

- Copper SFP transceivers:
 - Connector: Four-pair, Category 5 shielded twisted-pair connectivity through an RJ-45 connector
 - 1000BASE-T (model number: SFP-1GE-T)
 - Pinout: MDI
 - Length: 328 ft/100 m

Copper interface specifications—see [“Gigabit Ethernet 1000BASE-T Copper Interface Specifications” on page 47](#)

- Bidirectional SFP transceivers:
 - Connector: Duplex LC/PC (Rx and Tx)
 - 1000BASE-BX (model number pairs: SFP-GE10KT13R14 with SFP-GE10KT14R13, SFP-GE10KT13R15 with SFP-GE10KT15R13, SFP-GE40KT13R15 with SFP-GE40KT15R13)

Optical interface specifications—see [“Fast Ethernet and Gigabit Ethernet Bidirectional SFP Optical Interface Specifications” on page 50](#)

NOTE: Do not install Gigabit Ethernet SFPs in the SONET/SDH port. The port will not recognize the SFP.

LEDs

OK/FAIL LED, one bicolor:

- Steady green—DPC is functioning normally.
- Blinking green—DPC is transitioning online or offline.
- Red—DPC has failed.

Link LED, one green per port:

- Off—No link.
- On steadily—Link is active.

The Link LEDs are labeled in groups of five:

- 0/0 for 0/0 through 0/4
- 0/5 for 0/5 through 0/9
- 1/0 for 1/0 through 1/4
- 1/5 for 1/5 through 1/9
- 2/0 for 2/0 through 2/4
- 2/5 for 2/5 through 2/9
- 3/0 for 3/0 through 3/4
- 3/5 for 3/5 through 3/9

**Related
Documentation**

- [MX Series DPC Overview on page 7](#)
- [DPCs Supported on MX240, MX480, and MX960 Routers on page 7](#)
- [Gigabit Ethernet 1000BASE Optical Interface Specifications on page 44](#)
- [Fast Ethernet and Gigabit Ethernet Bidirectional SFP Optical Interface Specifications on page 50](#)

Gigabit Ethernet Enhanced Ethernet Services DPC with SFP

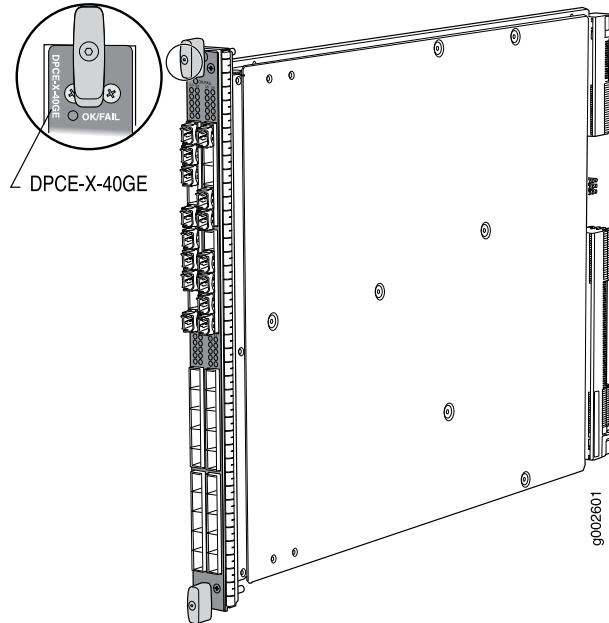

Software release	<ul style="list-style-type: none"> Junos OS Release 8.4 and later
Description	<ul style="list-style-type: none"> 40 Gigabit Ethernet ports Power requirement: 6.98 A @ 48 V (335 W) Weight: 13.1 lb (5.9 kg) Supports large Ethernet frame sizes for more efficient throughput across the intra-POP network Model number: DPCE-X-40GE-SFP Name in the CLI: DPCE 40x 1GE X
Hardware features	<ul style="list-style-type: none"> High-performance throughput on each port at speeds up to 1 Gbps Autonegotiation between Gigabit Ethernet circuit partners Full-duplex mode Maximum transmission units (MTUs) of up to 9192 bytes Enhanced ASICs for increased performance and scalability of Layer 2 features
Software features	<ul style="list-style-type: none"> Optical diagnostics and related alarms See “Protocols and Applications Supported by Enhanced Ethernet Services DPCs (DPCE-X)” on page 303 for information about the protocols and applications that this DPC supports. <p>NOTE: The routing table is limited to 32,000 IP routes. This limitation applies to any manner in which the routes are learned, such as OSPF, RIP, and so on. The DPC supports BGP for L2 VPNs only.</p>

Interfaces

Syntax: *ge-fpc/pic/port* where:

- fpc: Slot in the router where the DPC is installed
- pic: 0 (bottom left row of 10 ports), 1 (bottom right row of 10 ports), 2 (top left row of 10 ports), or 3 (top right row of 10 ports)
- port: 0 through 9

For example, *ge-1/3/0* is the interface for port 0 in the top right row of 10 ports on a DPC installed in slot 1.

Cables and connectors

- You can install any transceiver supported by the DPC. For information about installing and removing transceivers, see the hardware guide for your router.

- Fiber-optic small form-factor pluggable (SFP) transceivers:

- Connector: Duplex LC/PC (Rx and Tx)
- 1000BASE-EX (model number: SFP-GE40KM)
- 1000BASE-LH (model number: SFP-1GE-LH)
- 1000BASE-LX (model number: SFP-1GE-LX)
- 1000BASE-SX (model number: SFP-1GE-SX)

Optical interface specifications—see [“Gigabit Ethernet 1000BASE Optical Interface Specifications” on page 44](#)

- Copper SFP transceivers:

- Connector: Four-pair, Category 5 shielded twisted-pair connectivity through an RJ-45 connector
- 1000BASE-T (model number: SFP-1GE-T)
- Pinout: MDI crossover
- Length: 328 ft/100 m

Copper interface specifications—see [“Gigabit Ethernet 1000BASE-T Copper Interface Specifications” on page 47](#)

- Bidirectional SFP transceivers:

- Connector: Duplex LC/PC (Rx and Tx)
- 1000BASE-BX (model number pairs: SFP-GE10KT13R14 with SFP-GE10KT14R13, SFP-GE10KT13R15 with SFP-GE10KT15R13, SFP-GE40KT13R15 with SFP-GE40KT15R13)

Optical interface specifications—see [“Fast Ethernet and Gigabit Ethernet Bidirectional SFP Optical Interface Specifications” on page 50](#)

NOTE: Do not install Gigabit Ethernet SFPs in the SONET/SDH port. The port will not recognize the SFP.

LEDs

OK/FAIL LED, one bicolor:

- Steady green—DPC is functioning normally.
- Blinking green—DPC is transitioning online or offline.
- Red—DPC has failed.

Link LED, one green per port:

- Off—No link.
- On steadily—Link is active.

The Link LEDs are labeled in groups of five:

- 0/0 for 0/0 through 0/4
- 0/5 for 0/5 through 0/9
- 1/0 for 1/0 through 1/4
- 1/5 for 1/5 through 1/9
- 2/0 for 2/0 through 2/4
- 2/5 for 2/5 through 2/9
- 3/0 for 3/0 through 3/4
- 3/5 for 3/5 through 3/9

**Related
Documentation**

- [MX Series DPC Overview on page 7](#)
- [DPCs Supported on MX240, MX480, and MX960 Routers on page 7](#)
- [Gigabit Ethernet 1000BASE Optical Interface Specifications on page 44](#)
- [Fast Ethernet and Gigabit Ethernet Bidirectional SFP Optical Interface Specifications on page 50](#)

Gigabit Ethernet Enhanced Queuing Ethernet Services DPC with SFP

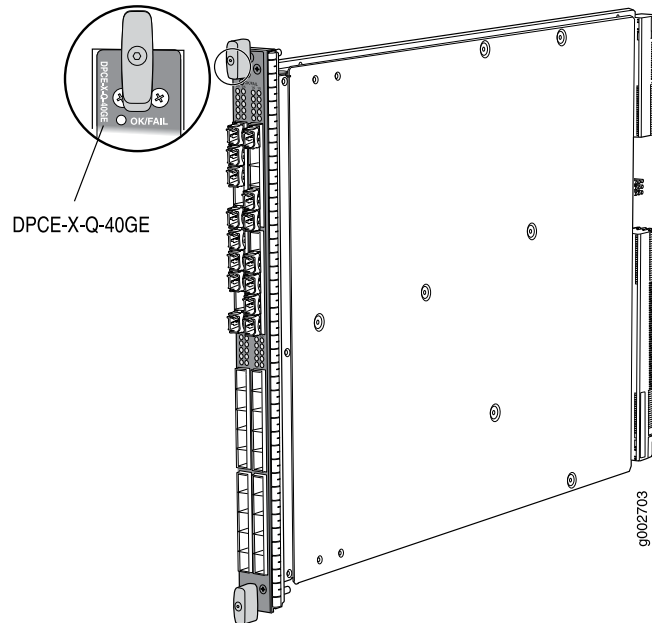

Software release	<ul style="list-style-type: none"> Junos OS Release 8.5 and later
Description	<ul style="list-style-type: none"> 40 Gigabit Ethernet ports Power requirement: 7.6 A @ 48 V (365 W) Weight: 13.1 lb (5.9 kg) Supports large Ethernet frame sizes for more efficient throughput across the intra-POP network Model number: DPCE-X-Q-40GE-SFP Name in the CLI: DPCE 40x 1GE X EQ
Hardware features	<ul style="list-style-type: none"> High-performance throughput on each port at speeds up to 1 Gbps Autonegotiation between Gigabit Ethernet circuit partners Full-duplex mode Maximum transmission units (MTUs) of up to 9192 bytes Enhanced ASICs for increased performance and scalability of Layer 2 features
Software features	<ul style="list-style-type: none"> Optical diagnostics and related alarms See “Protocols and Applications Supported by Enhanced Queuing Ethernet Services DPCs (DPCE-X-Q)” on page 312 for information about the protocols and applications that this DPC supports. <p>NOTE: The routing table is limited to 32,000 IP routes. This limitation applies to any manner in which the routes are learned, such as OSPF, RIP, and so on. The DPC supports BGP for L2 VPNs only.</p>

Interfaces

Syntax: *ge-fpc/pic/port* where:

- fpc: Slot in the router where the DPC is installed
- pic: 0 (bottom left row of 10 ports), 1 (bottom right row of 10 ports), 2 (top left row of 10 ports), or 3 (top right row of 10 ports)
- port: 0 through 9

For example, *ge-1/3/0* is the interface for port 0 in the top right row of 10 ports on a DPC installed in slot 1.

Cables and connectors

- You can install any transceiver supported by the DPC. For information about installing and removing transceivers, see the hardware guide for your router.
- Fiber-optic small form-factor pluggable (SFP) transceivers:
 - Connector: Duplex LC/PC (Rx and Tx)
 - 1000BASE-EX (model number: SFP-GE40KM)
 - 1000BASE-LH (model number: SFP-1GE-LH)
 - 1000BASE-LX (model number: SFP-1GE-LX)
 - 1000BASE-SX (model number: SFP-1GE-SX)

Optical interface specifications—see [“Gigabit Ethernet 1000BASE Optical Interface Specifications” on page 44](#)

- Copper SFP transceivers:
 - Connector: Four-pair, Category 5 shielded twisted-pair connectivity through an RJ-45 connector
 - 1000BASE-T (model number: SFP-1GE-T)
 - Pinout: MDI crossover
 - Length: 328 ft/100 m

Copper interface specifications—see [“Gigabit Ethernet 1000BASE-T Copper Interface Specifications” on page 47](#)

- Bidirectional SFP transceivers:
 - Connector: Duplex LC/PC (Rx and Tx)
 - 1000BASE-BX (model number pairs: SFP-GE10KT13R14 with SFP-GE10KT14R13, SFP-GE10KT13R15 with SFP-GE10KT15R13, SFP-GE40KT13R15 with SFP-GE40KT15R13)

Optical interface specifications—see [“Fast Ethernet and Gigabit Ethernet Bidirectional SFP Optical Interface Specifications” on page 50](#)

NOTE: Do not install Gigabit Ethernet SFPs in the SONET/SDH port. The port will not recognize the SFP.

LEDs

OK/FAIL LED, one bicolor:

- Steady green—DPC is functioning normally.
- Blinking green—DPC is transitioning online or offline.
- Red—DPC has failed.

Link LED, one green per port:

- Off—No link.
- On steadily—Link is active.

The Link LEDs are labeled in groups of five:

- 0/0 for 0/0 through 0/4
- 0/5 for 0/5 through 0/9
- 1/0 for 1/0 through 1/4
- 1/5 for 1/5 through 1/9
- 2/0 for 2/0 through 2/4
- 2/5 for 2/5 through 2/9
- 3/0 for 3/0 through 3/4
- 3/5 for 3/5 through 3/9

**Related
Documentation**

- [MX Series DPC Overview on page 7](#)
- [DPCs Supported on MX240, MX480, and MX960 Routers on page 7](#)
- [Gigabit Ethernet 1000BASE Optical Interface Specifications on page 44](#)
- [Fast Ethernet and Gigabit Ethernet Bidirectional SFP Optical Interface Specifications on page 50](#)

Gigabit Ethernet Enhanced Queuing IP Services DPCs with SFP

Figure 2: 20-Port Gigabit Ethernet Enhanced Queuing IP Services DPC with SFP

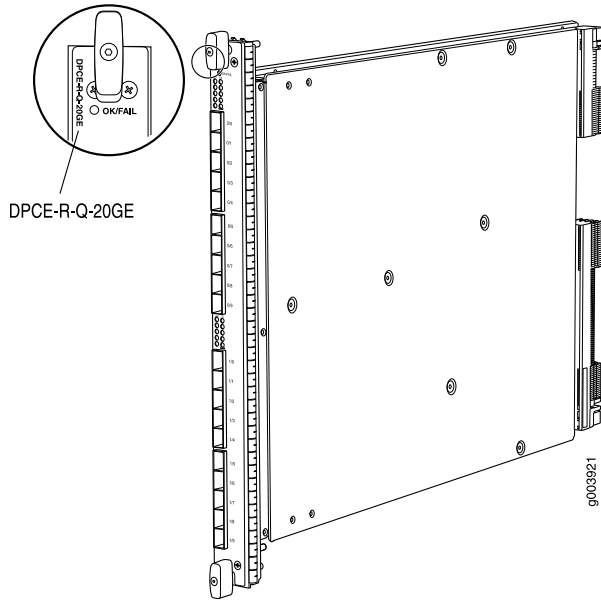
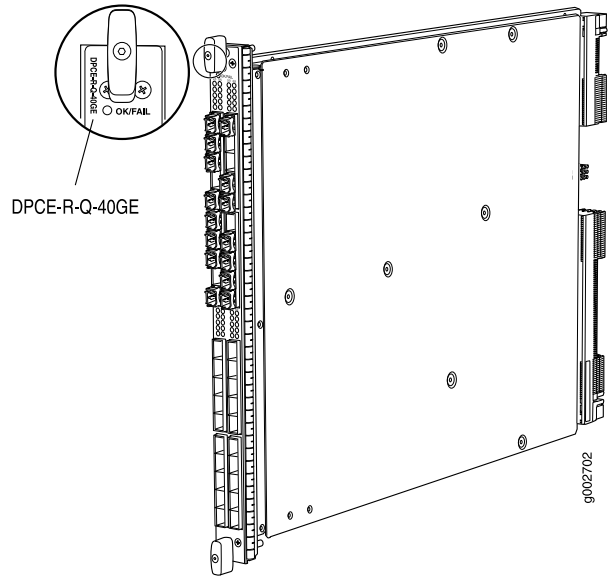

Figure 3: 40-Port Gigabit Ethernet Enhanced Queuing IP Services DPC with SFP



Software release	<ul style="list-style-type: none"> 20-port: Junos OS Release 9.1 and later 40-port: Junos OS Release 8.5 and later End-of-life (see notification PSN-2011-07-314)
------------------	--

Description	20-port: <ul style="list-style-type: none"> 20 Gigabit Ethernet ports Power requirement: 4.2 A @ 48 V (200 W) Weight: 13 lb (5.9 kg) Model number: DPCE-R-Q-20GE-SFP Name in the CLI: DPCE 20x 1GE R EQ 40-port: <ul style="list-style-type: none"> 40 Gigabit Ethernet ports Power requirement: 7.6 A @ 48 V (365 W) Weight: 13.1 lb (5.9 kg) Model number: DPCE-R-Q-40GE-SFP Name in the CLI: DPCE 40x 1GE R EQ
-------------	---

Hardware features	<ul style="list-style-type: none"> High-performance throughput on each port at speeds up to 1 Gbps Autonegotiation between Gigabit Ethernet circuit partners Full-duplex mode Maximum transmission units (MTUs) of up to 9192 bytes Enhanced ASICs for increased performance and scalability of Layer 2 features
-------------------	---

Software features	<ul style="list-style-type: none"> Optical diagnostics and related alarms See “Protocols and Applications Supported by Enhanced Queuing IP Services DPCs (DPCE-R-Q)” on page 308 for information about the protocols and applications that this DPC supports.
Interfaces	<p>Syntax: <i>ge-fpc/pic/port</i> where:</p> <ul style="list-style-type: none"> fpc: Slot in the router where the DPC is installed pic: <ul style="list-style-type: none"> 20-port: 0 (left row of 10 ports), or 1 (right row of 10 ports) 40-port: 0 (bottom left row of 10 ports), 1 (bottom right row of 10 ports), 2 (top left row of 10 ports), or 3 (top right row of 10 ports) port: 0 through 9 <p>For example, <i>ge-1/1/0</i> is the interface for port 0 in the (top for 40-port) right row of 10 ports on a DPC installed in slot 1.</p>
Cables and connectors	<ul style="list-style-type: none"> You can install any transceiver supported by the DPC. For information about installing and removing transceivers, see the hardware guide for your router. Fiber-optic small form-factor pluggable (SFP) transceivers: <ul style="list-style-type: none"> Connector: Duplex LC/PC (Rx and Tx) 1000BASE-EX (model number: SFP-GE40KM) 1000BASE-LH (model number: SFP-1GE-LH) 1000BASE-LX (model number: SFP-1GE-LX) 1000BASE-SX (model number: SFP-1GE-SX) <p>Optical interface specifications—see “Gigabit Ethernet 1000BASE Optical Interface Specifications” on page 44</p> Copper SFP transceivers: <ul style="list-style-type: none"> Connector: Four-pair, Category 5 shielded twisted-pair connectivity through an RJ-45 connector 1000BASE-T (model number: SFP-1GE-T) Pinout: MDI crossover Length: 328 ft/100 m <p>Copper interface specifications—see “Gigabit Ethernet 1000BASE-T Copper Interface Specifications” on page 47</p> Bidirectional SFP transceivers: <ul style="list-style-type: none"> Connector: Duplex LC/PC (Rx and Tx) 1000BASE-BX (model number pairs: SFP-GE10KT13R14 with SFP-GE10KT14R13, SFP-GE10KT13R15 with SFP-GE10KT15R13, SFP-GE40KT13R15 with SFP-GE40KT15R13) <p>Optical interface specifications—see “Fast Ethernet and Gigabit Ethernet Bidirectional SFP Optical Interface Specifications” on page 50</p> <p>NOTE: Do not install Gigabit Ethernet SFPs in the SONET/SDH port. The port will not recognize the SFP.</p>

LEDs

OK/FAIL LED, one bicolor:

- Steady green—DPC is functioning normally.
- Blinking green—DPC is transitioning online or offline.
- Red—DPC has failed.

Link LED, one green per port:

- Off—No link.
- On steadily—Link is active.

The Link LEDs are labeled in groups of five:

- 20-port:
 - 0/0 for 0/0 through 0/4
 - 0/5 for 0/5 through 0/9
 - 1/0 for 1/0 through 1/4
 - 1/5 for 1/5 through 1/9
- 40-port:
 - 0/0 for 0/0 through 0/4
 - 0/5 for 0/5 through 0/9
 - 1/0 for 1/0 through 1/4
 - 1/5 for 1/5 through 1/9
 - 2/0 for 2/0 through 2/4
 - 2/5 for 2/5 through 2/9
 - 3/0 for 3/0 through 3/4
 - 3/5 for 3/5 through 3/9

- Related Documentation**
- [MX Series DPC Overview on page 7](#)
 - [DPCs Supported on MX240, MX480, and MX960 Routers on page 7](#)
 - [Gigabit Ethernet 1000BASE Optical Interface Specifications on page 44](#)
 - [Fast Ethernet and Gigabit Ethernet Bidirectional SFP Optical Interface Specifications on page 50](#)

10-Gigabit Ethernet DPC with XFP

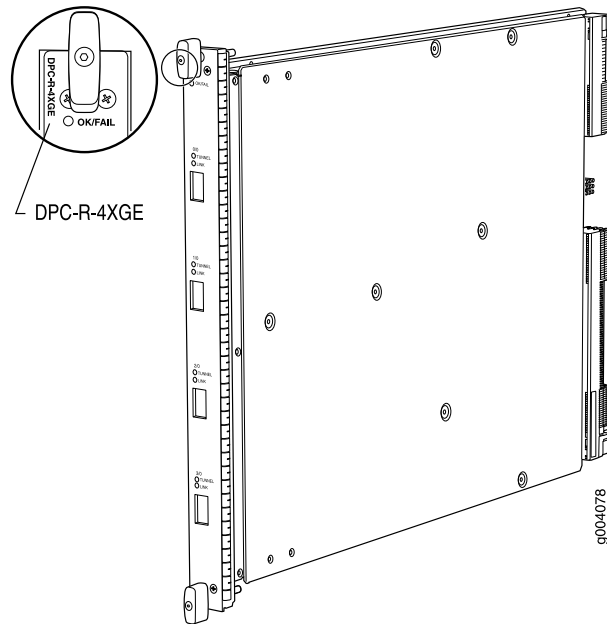

Software release	<ul style="list-style-type: none"> • Junos OS Release 8.2 and later • End-of-life (see notification PSN-2009-06-400)
Description	<ul style="list-style-type: none"> • Four 10-Gigabit Ethernet ports • Power requirement: 6.46 A @ 48 V (310 W) • Weight: 13.1 lb (5.9 kg) • Model number: DPC-R-4XGE-XFP • Name in the CLI: DPC 4x 10GE R
Hardware features	<ul style="list-style-type: none"> • High-performance throughput on each port at speeds up to 10 Gbps • WAN-PHY mode at 9.953 Gbps • LAN-PHY mode at 10.3125 Gbps • Full-duplex mode • Maximum transmission units (MTUs) of up to 9192 bytes
Software features	<ul style="list-style-type: none"> • Configurable WAN-PHY mode options • See "Protocols and Applications Supported by DPCs and Enhanced DPCs (DPC and DPCE-R)" on page 297 for information about the protocols and applications that this DPC supports.

Interfaces	<p>Syntax: <i>xe-fpc/pic/port</i> where:</p> <ul style="list-style-type: none"> • fpc: Slot in the router where the DPC is installed • pic: 0 through 3 • port: 0 <p>For example, <i>xe-1/3/0</i> is the interface for the last port on a DPC installed in slot 1.</p>
Cables and connectors	<ul style="list-style-type: none"> • You can install any transceiver supported by the DPC. For information about installing and removing transceivers, see the hardware guide for your router. • Fiber-optic 10-gigabit small form-factor pluggable (XFP) transceivers: <ul style="list-style-type: none"> • Connector: Duplex LC/PC (Rx and Tx) • 10GBASE-E (model number: XFP-10G-E-OC192-IR2) • 10GBASE-L (model number: XFP-10G-L-OC192-SR1) • 10GBASE-S (model number: XFP-10G-S) • 10GBASE-Z (model number: XFP-10G-Z-OC192-LR2) <p>Optical interface specifications—see "10-Gigabit Ethernet 10GBASE Optical Interface Specifications" on page 54</p>
LEDs	<p>OK/FAIL LED, one bicolor:</p> <ul style="list-style-type: none"> • Steady green—DPC is functioning normally. • Blinking green—DPC is transitioning online or offline. • Red—DPC has failed. <p>TUNNEL LED, one green per port:</p> <ul style="list-style-type: none"> • Off—Normal operating mode. • On steadily—Port configured in tunnel mode. <p>LINK LED, one green per port:</p> <ul style="list-style-type: none"> • Off—No link. • On steadily—Link is active. <p>The TUNNEL and LINK LEDs are labeled top to bottom 0/0 through 3/0.</p>

- Related Documentation**
- [MX Series DPC Overview on page 7](#)
 - [DPCs Supported on MX240, MX480, and MX960 Routers on page 7](#)
 - [10-Gigabit Ethernet 10GBASE Optical Interface Specifications on page 54](#)

10-Gigabit Ethernet Enhanced DPCs with XFP

Figure 4: 2-Port 10-Gigabit Ethernet Enhanced DPC with XFP

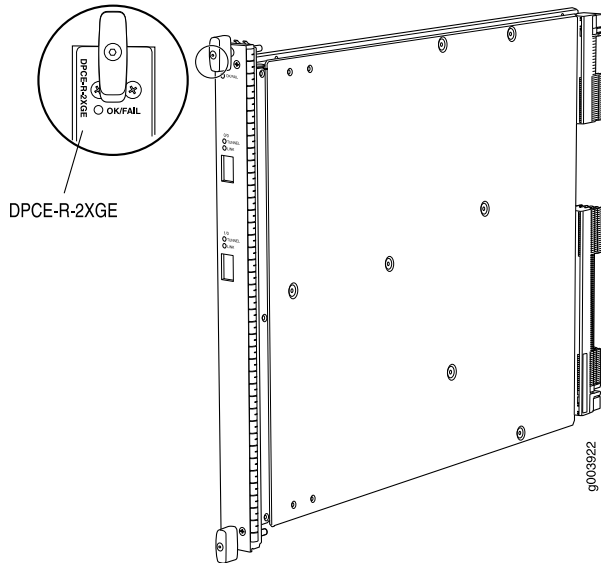
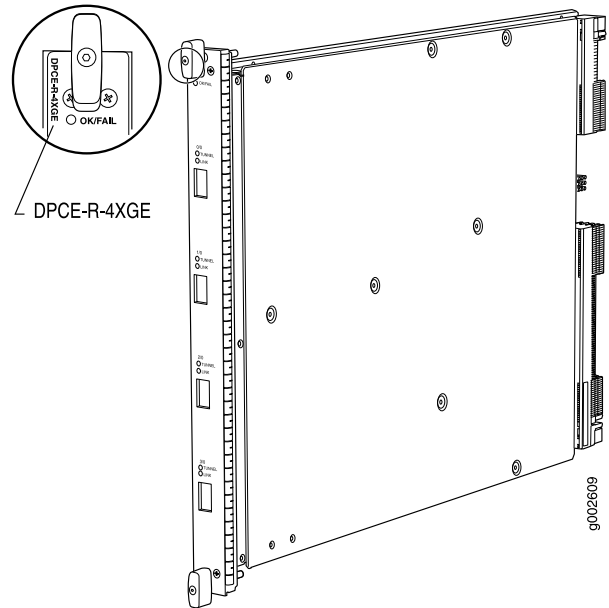

Figure 5: 4-Port 10-Gigabit Ethernet Enhanced DPC with XFP



- | | |
|------------------|---|
| Software release | <ul style="list-style-type: none"> • 2-port: Junos OS Release 9.1 and later
End-of-life (see notification PSN-2011-02-314) • 4-port: Junos OS Release 8.4 and later |
|------------------|---|

- | | |
|-------------|--|
| Description | <p>2-port:</p> <ul style="list-style-type: none"> • Two 10-Gigabit Ethernet ports • Power requirement: 3.65 A @ 48 V (175 W) • Weight: 12 lb (5.4 kg) • Model number: DPCE-R-2XGE-XFP • Name in the CLI: DPCE 2x 10GE R <p>4-port:</p> <ul style="list-style-type: none"> • Four 10-Gigabit Ethernet ports • Power requirement: 6.46 A @ 48 V (310 W) • Weight: 13.1 lb (5.9 kg) • Model number: DPCE-R-4XGE-XFP • Name in the CLI: DPCE 4x 10GE R |
|-------------|--|

Hardware features	<ul style="list-style-type: none"> • High-performance throughput on each port at speeds up to 10 Gbps • WAN-PHY mode at 9.953 Gbps • LAN-PHY mode at 10.3125 Gbps • Full-duplex mode • Maximum transmission units (MTUs) of up to 9192 bytes • Enhanced ASICs for increased performance and scalability of Layer 2 features
Software features	<ul style="list-style-type: none"> • Configurable WAN-PHY mode options • See “Protocols and Applications Supported by DPCs and Enhanced DPCs (DPC and DPCE-R)” on page 297 for information about the protocols and applications that these DPCs support.
Interfaces	<p>Syntax: <code>xe-fpc/pic/port</code> where:</p> <ul style="list-style-type: none"> • fpc: Slot in the router where the DPC is installed • pic: <ul style="list-style-type: none"> • 2-port: 0 or 1 • 4-port: 0 through 3 • port: 0 <p>For example, <code>xe-1/0/0</code> is the interface for the first port on a DPC installed in slot 1.</p>
Cables and connectors	<ul style="list-style-type: none"> • You can install any transceiver supported by the DPC. For information about installing and removing transceivers, see the hardware guide for your router. • Fiber-optic 10-gigabit small form-factor pluggable (XFP) transceivers: <ul style="list-style-type: none"> • Connector: Duplex LC/PC (Rx and Tx) • 10GBASE-E (model number: XFP-10G-E-OC192-IR2) • 10GBASE-L (model number: XFP-10G-L-OC192-SR1) • 10GBASE-S (model number: XFP-10G-S) • 10GBASE-Z (model number: XFP-10G-Z-OC192-LR2) <p>Optical interface specifications—see “10-Gigabit Ethernet 10GBASE Optical Interface Specifications” on page 54</p> • DWDM Tunable XFP transceivers: <ul style="list-style-type: none"> • Connector: Duplex LC/PC (Rx and Tx) • 10GBASE-ZR (model number: XFP-10G-CBAND-T50-ZR) <p>DWDM supported wavelengths—see 10-Gigabit Ethernet DWDM Transceiver Wavelengths</p> <p>NOTE: XFP-10G-CBAND-T50-ZR is supported in Junos OS Release 10.2 and later</p> <p>Optical interface specifications—see “10-Gigabit Ethernet 10GBASE Optical Interface Specifications” on page 54</p>

LEDs

OK/FAIL LED, one bicolor:

- Steady green—DPC is functioning normally.
- Blinking green—DPC is transitioning online or offline.
- Red—DPC has failed.

TUNNEL LED, one green per port:

- Off—Normal operating mode.
- On steadily—Port configured in tunnel mode.

LINK LED, one green per port:

- Off—No link.
- On steadily—Link is active.

The **TUNNEL** and **LINK** LEDs are labeled top to bottom:

- 2-port: 0/0 through 1/0
- 4-port: 0/0 through 3/0

Related Documentation

- [MX Series DPC Overview on page 7](#)
- [DPCs Supported on MX240, MX480, and MX960 Routers on page 7](#)
- [10-Gigabit Ethernet 10GBASE Optical Interface Specifications on page 54](#)

10-Gigabit Ethernet Enhanced Ethernet Services DPC with XFP

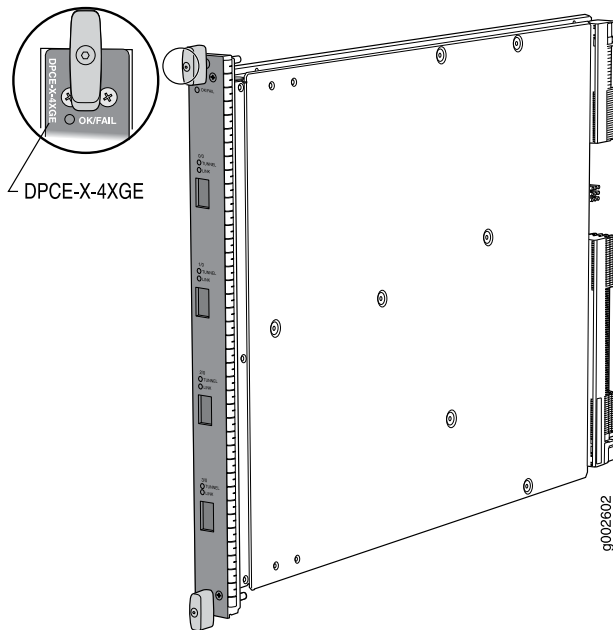

Software release

- Junos OS Release 8.4 and later

Description	<ul style="list-style-type: none"> • Four 10-Gigabit Ethernet ports • Power requirement: 6.46 A @ 48 V (310 W) • Weight: 13.1 lb (5.9 kg) • Model number: DPCE-X-4XGE-XFP • Name in the CLI: DPCE 4x 10GE X
Hardware features	<ul style="list-style-type: none"> • High-performance throughput on each port at speeds up to 10 Gbps • WAN-PHY mode at 9.953 Gbps • LAN-PHY mode at 10.3125 Gbps • Full-duplex mode • Maximum transmission units (MTUs) of up to 9192 bytes • Enhanced ASICs for increased performance and scalability of Layer 2 features
Software features	<ul style="list-style-type: none"> • Configurable WAN-PHY mode options • See “Protocols and Applications Supported by Enhanced Ethernet Services DPCs (DPCE-X)” on page 303 for information about the protocols and applications that this DPC supports. <p>NOTE: The routing table is limited to 32,000 IP routes. This limitation applies to any manner in which the routes are learned, such as OSPF, RIP, and so on. The DPC supports BGP for L2 VPNs only.</p>
Interfaces	<p>Syntax: <code>xe-fpc/pic/port</code> where:</p> <ul style="list-style-type: none"> • fpc: Slot in the router where the DPC is installed • pic: 0 through 3 • port: 0 <p>For example, <code>xe-1/0/0</code> is the interface for the first port on a DPC installed in slot 1.</p>
Cables and connectors	<ul style="list-style-type: none"> • You can install any transceiver supported by the DPC. For information about installing and removing transceivers, see the hardware guide for your router. • Fiber-optic 10-gigabit small form-factor pluggable (XFP) transceivers: <ul style="list-style-type: none"> • Connector: Duplex LC/PC (Rx and Tx) • 10GBASE-E (model number: XFP-10G-E-OC192-IR2) • 10GBASE-L (model number: XFP-10G-L-OC192-SR1) • 10GBASE-S (model number: XFP-10G-S) • 10GBASE-Z (model number: XFP-10G-Z-OC192-LR2) <p>Optical interface specifications—see “10-Gigabit Ethernet 10GBASE Optical Interface Specifications” on page 54</p> • DWDM Tunable XFP transceivers: <ul style="list-style-type: none"> • Connector: Duplex LC/PC (Rx and Tx) • 10GBASE-ZR (model number: XFP-10G-CBAND-T50-ZR) <p>DWDM supported wavelengths—see 10-Gigabit Ethernet DWDM Transceiver Wavelengths</p> <p>NOTE: XFP-10G-CBAND-T50-ZR is supported in Junos OS Release 10.2 and later</p> <p>Optical interface specifications—see “10-Gigabit Ethernet 10GBASE Optical Interface Specifications” on page 54</p>

LEDs

OK/FAIL LED, one bicolor:

- Steady green—DPC is functioning normally.
- Blinking green—DPC is transitioning online or offline.
- Red—DPC has failed.

TUNNEL LED, one green per port:

- Off—Normal operating mode.
- On steadily—Port configured in tunnel mode.

LINK LED, one green per port:

- Off—No link.
- On steadily—Link is active.

The **TUNNEL** and **LINK** LEDs are labeled top to bottom **0/0** through **3/0**.

**Related
Documentation**

- [MX Series DPC Overview on page 7](#)
- [DPCs Supported on MX240, MX480, and MX960 Routers on page 7](#)
- [10-Gigabit Ethernet 10GBASE Optical Interface Specifications on page 54](#)

10-Gigabit Ethernet Enhanced Queuing Ethernet Services DPC with XFP

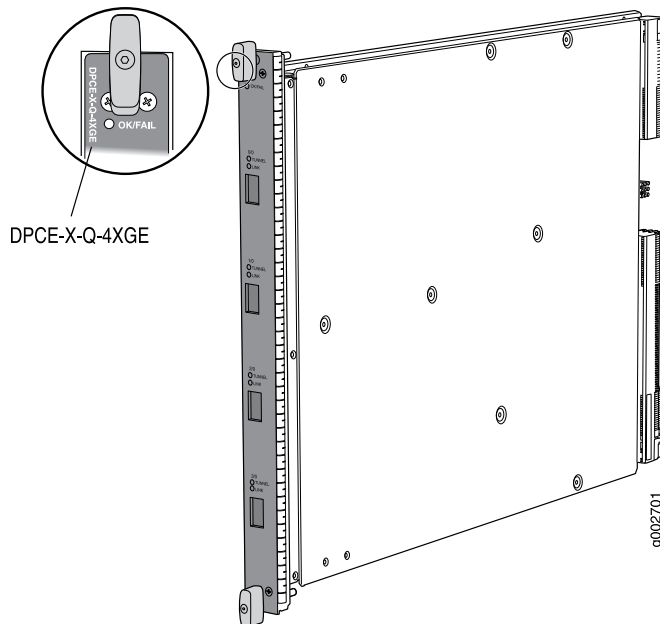

Software release

- Junos OS Release 8.5 and later

Description	<ul style="list-style-type: none"> • Four 10-Gigabit Ethernet ports • Power requirement: 6.87 A @ 48 V (330 W) • Weight: 13.1 lb (5.9 kg) • Model number: DPCE-X-Q-4XGE-XFP • Name in the CLI: DPCE 4x 10GE X EQ
Hardware features	<ul style="list-style-type: none"> • High-performance throughput on each port at speeds up to 10 Gbps • WAN-PHY mode at 9.953 Gbps • LAN-PHY mode at 10.3125 Gbps • Full-duplex mode • Maximum transmission units (MTUs) of up to 9192 bytes • Enhanced ASICs for increased performance and scalability of Layer 2 features
Software features	<ul style="list-style-type: none"> • Configurable WAN-PHY mode options • See “Protocols and Applications Supported by Enhanced Queuing Ethernet Services DPCs (DPCE-X-Q)” on page 312 for information about the protocols and applications that this DPC supports. <p>NOTE: The routing table is limited to 32,000 IP routes. This limitation applies to any manner in which the routes are learned, such as OSPF, RIP, and so on. The DPC supports BGP for L2 VPNs only.</p>
Interfaces	<p>Syntax: <code>xe-fpc/pic/port</code> where:</p> <ul style="list-style-type: none"> • fpc: Slot in the router where the DPC is installed • pic: 0 through 3 • port: 0 <p>For example, <code>xe-1/0/0</code> is the interface for the first port on a DPC installed in slot 1.</p>
Cables and connectors	<ul style="list-style-type: none"> • You can install any transceiver supported by the DPC. For information about installing and removing transceivers, see the hardware guide for your router. • Fiber-optic 10-gigabit small form-factor pluggable (XFP) transceivers: <ul style="list-style-type: none"> • Connector: Duplex LC/PC (Rx and Tx) • 10GBASE-E (model number: XFP-10G-E-OC192-IR2) • 10GBASE-L (model number: XFP-10G-L-OC192-SR1) • 10GBASE-S (model number: XFP-10G-S) • 10GBASE-Z (model number: XFP-10G-Z-OC192-LR2) <p>Optical interface specifications—see “10-Gigabit Ethernet 10GBASE Optical Interface Specifications” on page 54</p> • DWDM Tunable XFP transceivers: <ul style="list-style-type: none"> • Connector: Duplex LC/PC (Rx and Tx) • 10GBASE-ZR (model number: XFP-10G-CBAND-T50-ZR) <p>DWDM supported wavelengths—see 10-Gigabit Ethernet DWDM Transceiver Wavelengths</p> <p>NOTE: XFP-10G-CBAND-T50-ZR is supported in Junos OS Release 10.2 and later</p> <p>Optical interface specifications—see “10-Gigabit Ethernet 10GBASE Optical Interface Specifications” on page 54</p>

LEDs

OK/FAIL LED, one bicolor:

- Steady green—DPC is functioning normally.
- Blinking green—DPC is transitioning online or offline.
- Red—DPC has failed.

TUNNEL LED, one green per port:

- Off—Normal operating mode.
- On steadily—Port configured in tunnel mode.

LINK LED, one green per port:

- Off—No link.
- On steadily—Link is active.

The **TUNNEL** and **LINK** LEDs are labeled top to bottom **0/0** through **3/0**.

**Related
Documentation**

- [MX Series DPC Overview on page 7](#)
- [DPCs Supported on MX240, MX480, and MX960 Routers on page 7](#)
- [10-Gigabit Ethernet 10GBASE Optical Interface Specifications on page 54](#)

10-Gigabit Ethernet Enhanced Queuing IP Services DPC with XFP

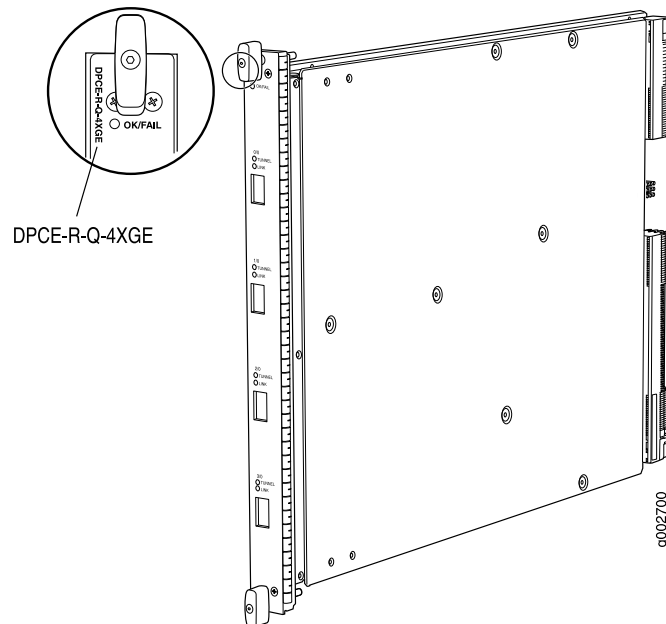

Software release

- Junos OS Release 8.5 and later
- End-of-life (see notification [PSN-2011-07-314](#))

Description	<ul style="list-style-type: none"> • Four 10-Gigabit Ethernet ports • Power requirement: 6.87 A @ 48 V (330 W) • Weight: 13.1 lb (5.9 kg) • Model number: DPCE-R-Q-4XGE-XFP • Name in the CLI: DPCE 4x 10GE R EQ
Hardware features	<ul style="list-style-type: none"> • High-performance throughput on each port at speeds up to 10 Gbps • WAN-PHY mode at 9.953 Gbps • LAN-PHY mode at 10.3125 Gbps • Full-duplex mode • Maximum transmission units (MTUs) of up to 9192 bytes • Enhanced ASICs for increased performance and scalability of Layer 2 features
Software features	<ul style="list-style-type: none"> • Configurable WAN-PHY mode options • See “Protocols and Applications Supported by Enhanced Queuing IP Services DPCs (DPCE-R-Q)” on page 308 for information about the protocols and applications that this DPC supports.
Interfaces	<p>Syntax: <i>xe-fpc/pic/port</i> where:</p> <ul style="list-style-type: none"> • fpc: Slot in the router where the DPC is installed • pic: 0 through 3 • port: 0 <p>For example, <i>xe-1/0/0</i> is the interface for the first port on a DPC installed in slot 1.</p>
Cables and connectors	<ul style="list-style-type: none"> • You can install any transceiver supported by the DPC. For information about installing and removing transceivers, see the hardware guide for your router. • Fiber-optic 10-gigabit small form-factor pluggable (XFP) transceivers: <ul style="list-style-type: none"> • Connector: Duplex LC/PC (Rx and Tx) • 10GBASE-E (model number: XFP-10G-E-OC192-IR2) • 10GBASE-L (model number: XFP-10G-L-OC192-SR1) • 10GBASE-S (model number: XFP-10G-S) • 10GBASE-Z (model number: XFP-10G-Z-OC192-LR2) <p>Optical interface specifications—see “10-Gigabit Ethernet 10GBASE Optical Interface Specifications” on page 54</p> • DWDM Tunable XFP transceivers: <ul style="list-style-type: none"> • Connector: Duplex LC/PC (Rx and Tx) • 10GBASE-ZR (model number: XFP-10G-CBAND-T50-ZR) <p>DWDM supported wavelengths—see 10-Gigabit Ethernet DWDM Transceiver Wavelengths</p> <p>NOTE: XFP-10G-CBAND-T50-ZR is supported in Junos OS Release 10.2 and later</p> <p>Optical interface specifications—see “10-Gigabit Ethernet 10GBASE Optical Interface Specifications” on page 54</p>

LEDs

OK/FAIL LED, one bicolor:

- Steady green—DPC is functioning normally.
- Blinking green—DPC is transitioning online or offline.
- Red—DPC has failed.

TUNNEL LED, one green per port:

- Off—Normal operating mode.
- On steadily—Port configured in tunnel mode.

LINK LED, one green per port:

- Off—No link.
- On steadily—Link is active.

The **TUNNEL** and **LINK** LEDs are labeled top to bottom **0/0** through **3/0**.

**Related
Documentation**

- [MX Series DPC Overview on page 7](#)
- [DPCs Supported on MX240, MX480, and MX960 Routers on page 7](#)
- [10-Gigabit Ethernet 10GBASE Optical Interface Specifications on page 54](#)

Multi-Rate Ethernet Enhanced DPC with SFP and XFP

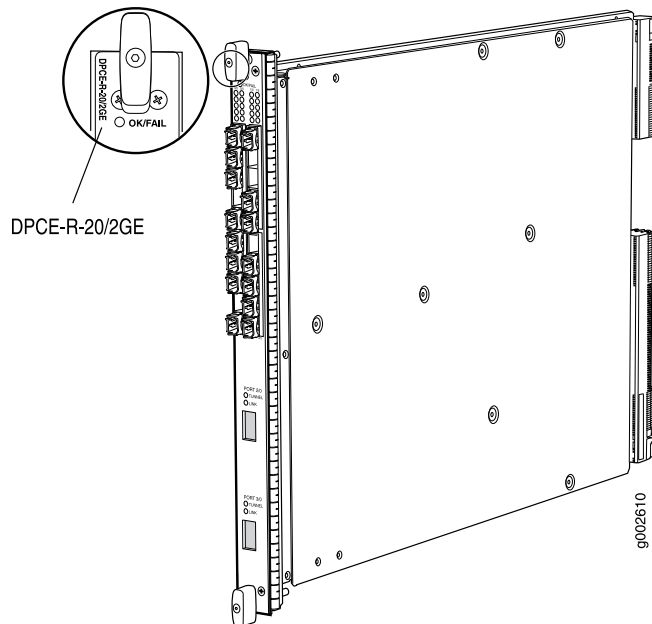

Software release

- Junos OS Release 9.2 and later

Description	<ul style="list-style-type: none"> • 20 Gigabit Ethernet ports • 2 10-Gigabit Ethernet ports • Power requirement: 6.94 A @ 48 V (333 W) • Weight: 13.1 lb (5.9 kg) • Supports large Ethernet frame sizes for more efficient throughput across the intra-POP network • Model number: DPCE-R-20GE-2XGE • Name in the CLI: DPCE 20x1GE + 2x 10GE R
Hardware features	<ul style="list-style-type: none"> • SFP ports: <ul style="list-style-type: none"> • High-performance throughput on each port at speeds up to 1 Gbps • XFP ports: <ul style="list-style-type: none"> • High-performance throughput on each port at speeds up to 10 Gbps • WAN-PHY mode at 9.953 Gbps • LAN-PHY mode at 10.3125 Gbps • Autonegotiation between Gigabit Ethernet circuit partners • Full-duplex mode • Maximum transmission units (MTUs) of up to 9192 bytes • Enhanced ASICs for increased performance and scalability of Layer 2 features
Software features	<ul style="list-style-type: none"> • Configurable WAN-PHY mode options • Optical diagnostics and related alarms • See “Protocols and Applications Supported by DPCs and Enhanced DPCs (DPC and DPCE-R)” on page 297 for information about the protocols and applications that this DPC supports.
Interfaces	<p>Syntax: <i>mediatype-fpc/pic/port</i> where:</p> <ul style="list-style-type: none"> • mediatype: ge or xe • fpc: Slot in the router where the DPC is installed • pic: <ul style="list-style-type: none"> • ge: 0 or 1 • xe: 2 or 3 • port: <ul style="list-style-type: none"> • ge: 0 through 9 • xe: 0 <p>For example, xe-1/3/0 is the interface for the port labeled PORT 3/0 on a DPC installed in slot 1.</p>

Cables and connectors

- You can install any transceiver supported by the DPC. For information about installing and removing transceivers, see the hardware guide for your router.
- Fiber-optic small form-factor pluggable (SFP) transceivers:
 - Connector: Duplex LC/PC (Rx and Tx)
 - 100BASE-FX (model number: SFP-1FE-FX) supported in Junos OS Release 9.3 and later
 - 1000BASE-EX (model number: SFP-GE40KM)
 - 1000BASE-LH (model number: SFP-1GE-LH)
 - 1000BASE-LX (model number: SFP-1GE-LX)
 - 1000BASE-SX (model number: SFP-1GE-SX)

Optical interface specifications—see [“Fast Ethernet 100BASE-FX Optical Interface Specifications” on page 48](#) and [“Gigabit Ethernet 1000BASE Optical Interface Specifications” on page 44](#)

- Copper SFP transceivers:
 - Connector: Four-pair, Category 5 shielded twisted-pair connectivity through an RJ-45 connector
 - 1000BASE-T (model number: SFP-1GE-T)
 - 10/100/1000BASE-T (model number: SFP-1GE-FE-E-T)

NOTE: SFP-1GE-FE-E-T supports tri-rate 10/100/1000 mode in Junos OS Release 9.4 and later

 - Pinout: MDI, MDI crossover
 - Length: 328 ft/100 m

Copper interface specifications—see [“Ethernet 10BASE-T Copper Interface Specifications” on page 48](#), [“Fast Ethernet 100BASE-T Copper Interface Specifications” on page 49](#), and [“Gigabit Ethernet 1000BASE-T Copper Interface Specifications” on page 47](#)

- Bidirectional SFP transceivers:
 - Connector: Duplex LC/PC (Rx and Tx)
 - 100BASE-BX (model number pairs: SFP-FE20KT13R15 with SFP-FE20KT15R13)
 - 1000BASE-BX (model number pairs: SFP-GE10KT13R14 with SFP-GE10KT14R13, SFP-GE10KT13R15 with SFP-GE10KT15R13, SFP-GE40KT13R15 with SFP-GE40KT15R13)

Optical interface specifications—see [“Fast Ethernet and Gigabit Ethernet Bidirectional SFP Optical Interface Specifications” on page 50](#)

- Fiber-optic 10-gigabit small form-factor pluggable (XFP) transceivers:
 - Connector: Duplex LC/PC (Rx and Tx)
 - 10GBASE-E (model number: XFP-10G-E-OC192-IR2)
 - 10GBASE-L (model number: XFP-10G-L-OC192-SR1)
 - 10GBASE-S (model number: XFP-10G-S)
 - 10GBASE-Z (model number: XFP-10G-Z-OC192-LR2)

Optical interface specifications—see [“10-Gigabit Ethernet 10GBASE Optical Interface Specifications” on page 54](#)

- DWDM Tunable XFP transceivers:
 - Connector: Duplex LC/PC (Rx and Tx)
 - 10GBASE-ZR (model number: XFP-10G-CBAND-T50-ZR)
DWDM supported wavelengths—see [10-Gigabit Ethernet DWDM Transceiver Wavelengths](#)

NOTE: XFP-10G-CBAND-T50-ZR is supported in Junos OS Release 10.2 and later

Optical interface specifications—see [“10-Gigabit Ethernet 10GBASE Optical Interface Specifications” on page 54](#)

LEDs

OK/FAIL LED, one bicolor:

- Steady green—DPC is functioning normally.
- Blinking green—DPC is transitioning online or offline.
- Red—DPC has failed.

LINK LED, one green per port:

- Off—No link.
- On steadily—Link is active.

TUNNEL LED, one green per XFP port:

- Off—Normal operating mode.
- On steadily—Port configured in tunnel mode.

The SFP Link LEDs are labeled in groups of five:

- 0/0 for 0/0 through 0/4
- 0/5 for 0/5 through 0/9
- 1/0 for 1/0 through 1/4
- 1/5 for 1/5 through 1/9

The XFP ports are labeled top to bottom 2/0 and 3/0.

**Related
Documentation**

- [MX Series DPC Overview on page 7](#)
- [DPCs Supported on MX240, MX480, and MX960 Routers on page 7](#)
- [Gigabit Ethernet 1000BASE Optical Interface Specifications on page 44](#)
- [Fast Ethernet and Gigabit Ethernet Bidirectional SFP Optical Interface Specifications on page 50](#)
- [10-Gigabit Ethernet 10GBASE Optical Interface Specifications on page 54](#)

Multi-Rate Ethernet Enhanced Ethernet Services DPC with SFP and XFP

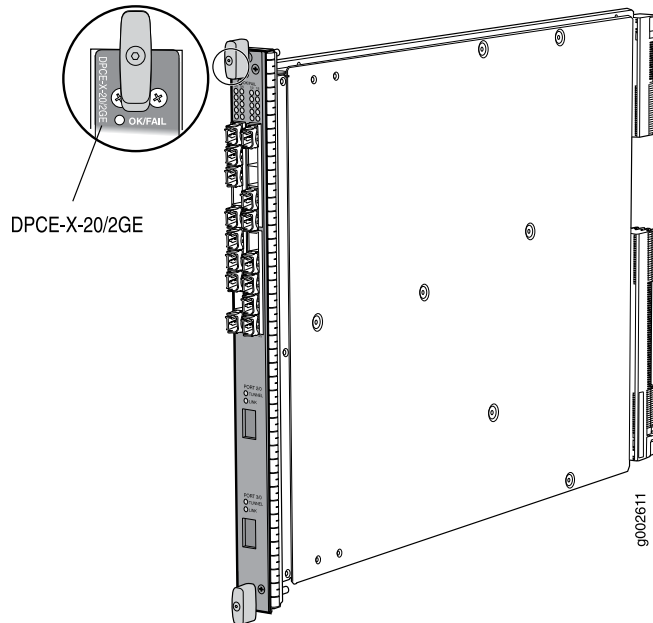

Software release	<ul style="list-style-type: none"> Junos OS Release 9.2 and later End-of-life (see notification PSN-2011-07-314)
Description	<ul style="list-style-type: none"> 20 Gigabit Ethernet ports 2 10-Gigabit Ethernet ports Power requirement: 6.94 A @ 48 V (333 W) Weight: 13.1 lb (5.9 kg) Supports large Ethernet frame sizes for more efficient throughput across the intra-POP network Model number: DPCE-X-20GE-2XGE Name in the CLI: DPCE 20x 1GE + 2x 10GE X
Hardware features	<ul style="list-style-type: none"> SFP ports: <ul style="list-style-type: none"> High-performance throughput on each port at speeds up to 1 Gbps XFP ports: <ul style="list-style-type: none"> High-performance throughput on each port at speeds up to 10 Gbps WAN-PHY mode at 9.953 Gbps LAN-PHY mode at 10.3125 Gbps Full-duplex mode Maximum transmission units (MTUs) of up to 9192 bytes Enhanced ASICs for increased performance and scalability of Layer 2 features
Software features	<ul style="list-style-type: none"> Configurable WAN-PHY mode options Optical diagnostics and related alarms See “Protocols and Applications Supported by Enhanced Ethernet Services DPCs (DPCE-X)” on page 303 for information about the protocols and applications that this DPC supports.

Interfaces

Syntax: *mediatype-fpc/pic/port* where:

- mediatype: ge or xe
- fpc: Slot in the router where the DPC is installed
- pic:
 - ge: 0 or 1
 - xe: 2 or 3
- port:
 - ge: 0 through 9
 - xe: 0

For example, xe-1/3/0 is the interface for the port labeled **PORT 3/0** on a DPC installed in slot 1.

Cables and connectors

- You can install any transceiver supported by the DPC. For information about installing and removing transceivers, see the hardware guide for your router.
- Fiber-optic small form-factor pluggable (SFP) transceivers:
 - Connector: Duplex LC/PC (Rx and Tx)
 - 100BASE-FX (model number: SFP-1FE-FX) supported in Junos OS Release 9.3 and later
 - 1000BASE-EX (model number: SFP-GE40KM)
 - 1000BASE-LH (model number: SFP-1GE-LH)
 - 1000BASE-LX (model number: SFP-1GE-LX)
 - 1000BASE-SX (model number: SFP-1GE-SX)

Optical interface specifications—see [“Fast Ethernet 100BASE-FX Optical Interface Specifications” on page 48](#) and [“Gigabit Ethernet 1000BASE Optical Interface Specifications” on page 44](#)

- Copper SFP transceivers:
 - Connector: Four-pair, Category 5 shielded twisted-pair connectivity through an RJ-45 connector
 - 1000BASE-T (model number: SFP-1GE-T)
 - 10/100/1000BASE-T (model number: SFP-1GE-FE-E-T)

NOTE: SFP-1GE-FE-E-T supports tri-rate 10/100/1000 mode in Junos OS Release 9.4 and later

 - Pinout: MDI, MDI crossover
 - Length: 328 ft/100 m

Copper interface specifications—see [“Ethernet 10BASE-T Copper Interface Specifications” on page 48](#), [“Fast Ethernet 100BASE-T Copper Interface Specifications” on page 49](#), and [“Gigabit Ethernet 1000BASE-T Copper Interface Specifications” on page 47](#)

- Bidirectional SFP transceivers:
 - Connector: Duplex LC/PC (Rx and Tx)
 - 100BASE-BX (model number pairs: SFP-FE20KT13R15 with SFP-FE20KT15R13)
 - 1000BASE-BX (model number pairs: SFP-GE10KT13R14 with SFP-GE10KT14R13, SFP-GE10KT13R15 with SFP-GE10KT15R13, SFP-GE40KT13R15 with SFP-GE40KT15R13)

Optical interface specifications—see [“Fast Ethernet and Gigabit Ethernet Bidirectional SFP Optical Interface Specifications” on page 50](#)

- Fiber-optic 10-gigabit small form-factor pluggable (XFP) transceivers:
 - Connector: Duplex LC/PC (Rx and Tx)
 - 10GBASE-E (model number: XFP-10G-E-OC192-IR2)
 - 10GBASE-L (model number: XFP-10G-L-OC192-SR1)
 - 10GBASE-S (model number: XFP-10G-S)
 - 10GBASE-Z (model number: XFP-10G-Z-OC192-LR2)

Optical interface specifications—see [“10-Gigabit Ethernet 10GBASE Optical Interface Specifications” on page 54](#)

- DWDM Tunable XFP transceivers:
 - Connector: Duplex LC/PC (Rx and Tx)
 - 10GBASE-ZR (model number: XFP-10G-CBAND-T50-ZR)
DWDM supported wavelengths—see [10-Gigabit Ethernet DWDM Transceiver Wavelengths](#)

NOTE: XFP-10G-CBAND-T50-ZR is supported in Junos OS Release 10.2 and later

Optical interface specifications—see [“10-Gigabit Ethernet 10GBASE Optical Interface Specifications” on page 54](#)

LEDs

OK/FAIL LED, one bicolor:

- Steady green—DPC is functioning normally.
- Blinking green—DPC is transitioning online or offline.
- Red—DPC has failed.

LINK LED, one green per port:

- Off—No link.
- On steadily—Link is active.

TUNNEL LED, one green per XFP port:

- Off—Normal operating mode.
- On steadily—Port configured in tunnel mode.

The SFP Link LEDs are labeled in groups of five:

- 0/0 for 0/0 through 0/4
- 0/5 for 0/5 through 0/9
- 1/0 for 1/0 through 1/4
- 1/5 for 1/5 through 1/9

The XFP ports are labeled top to bottom 2/0 and 3/0.

**Related
Documentation**

- [MX Series DPC Overview on page 7](#)
- [DPCs Supported on MX240, MX480, and MX960 Routers on page 7](#)
- [Gigabit Ethernet 1000BASE Optical Interface Specifications on page 44](#)
- [Fast Ethernet and Gigabit Ethernet Bidirectional SFP Optical Interface Specifications on page 50](#)
- [10-Gigabit Ethernet 10GBASE Optical Interface Specifications on page 54](#)

Multi-Rate Ethernet Enhanced Queuing IP Services DPC with SFP and XFP

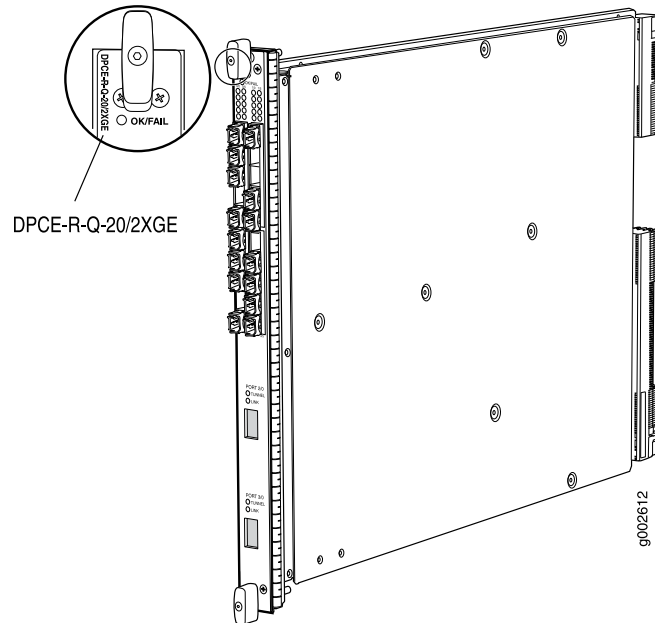

Software release	<ul style="list-style-type: none"> Junos OS Release 9.3 and later
Description	<ul style="list-style-type: none"> 20 Gigabit Ethernet ports 2 10-Gigabit Ethernet ports Power requirement: 6.98 A @ 48 V (335 W) Weight: 13.1 lb (5.9 kg) Supports large Ethernet frame sizes for more efficient throughput across the intra-POP network Model number: DPCE-R-Q-20GE-2XGE Name in the CLI: DPCE 20x 1GE + 2x 10GE R EQ
Hardware features	<ul style="list-style-type: none"> SFP ports: <ul style="list-style-type: none"> High-performance throughput on each port at speeds up to 1 Gbps XFP ports: <ul style="list-style-type: none"> High-performance throughput on each port at speeds up to 10 Gbps WAN-PHY mode at 9.953 Gbps LAN-PHY mode at 10.3125 Gbps Full-duplex mode Maximum transmission units (MTUs) of up to 9192 bytes Enhanced ASICs for increased performance and scalability of Layer 2 features
Software features	<ul style="list-style-type: none"> Configurable WAN-PHY mode options Optical diagnostics and related alarms See “Protocols and Applications Supported by Enhanced Queuing IP Services DPCs (DPCE-R-Q)” on page 308 for information about the protocols and applications that this DPC supports.

Interfaces

Syntax: *mediatype-fpc/pic/port* where:

- mediatype: ge or xe
- fpc: Slot in the router where the DPC is installed
- pic:
 - ge: 0 or 1
 - xe: 2 or 3
- port:
 - ge: 0 through 9
 - xe: 0

For example, xe-1/3/0 is the interface for the port labeled **PORT 3/0** on a DPC installed in slot 1.

Cables and connectors

- You can install any transceiver supported by the DPC. For information about installing and removing transceivers, see the hardware guide for your router.
- Fiber-optic small form-factor pluggable (SFP) transceivers:
 - Connector: Duplex LC/PC (Rx and Tx)
 - 100BASE-FX (model number: SFP-1FE-FX) supported in Junos OS Release 9.3 and later
 - 1000BASE-EX (model number: SFP-GE40KM)
 - 1000BASE-LH (model number: SFP-1GE-LH)
 - 1000BASE-LX (model number: SFP-1GE-LX)
 - 1000BASE-SX (model number: SFP-1GE-SX)

Optical interface specifications—see [“Fast Ethernet 100BASE-FX Optical Interface Specifications” on page 48](#) and [“Gigabit Ethernet 1000BASE Optical Interface Specifications” on page 44](#)

- Copper SFP transceivers:
 - Connector: Four-pair, Category 5 shielded twisted-pair connectivity through an RJ-45 connector
 - 1000BASE-T (model number: SFP-1GE-T)
 - 10/100/1000BASE-T (model number: SFP-1GE-FE-E-T)

NOTE: SFP-1GE-FE-E-T supports tri-rate 10/100/1000 mode in Junos OS Release 9.4 and later

 - Pinout: MDI, MDI crossover
 - Length: 328 ft/100 m

Copper interface specifications—see [“Ethernet 10BASE-T Copper Interface Specifications” on page 48](#), [“Fast Ethernet 100BASE-T Copper Interface Specifications” on page 49](#), and [“Gigabit Ethernet 1000BASE-T Copper Interface Specifications” on page 47](#)

- Bidirectional SFP transceivers:
 - Connector: Duplex LC/PC (Rx and Tx)
 - 100BASE-BX (model number pairs: SFP-FE20KT13R15 with SFP-FE20KT15R13)
 - 1000BASE-BX (model number pairs: SFP-GE10KT13R14 with SFP-GE10KT14R13, SFP-GE10KT13R15 with SFP-GE10KT15R13, SFP-GE40KT13R15 with SFP-GE40KT15R13)

Optical interface specifications—see [“Fast Ethernet and Gigabit Ethernet Bidirectional SFP Optical Interface Specifications” on page 50](#)

- Fiber-optic 10-gigabit small form-factor pluggable (XFP) transceivers:
 - Connector: Duplex LC/PC (Rx and Tx)
 - 10GBASE-E (model number: XFP-10G-E-OC192-IR2)
 - 10GBASE-L (model number: XFP-10G-L-OC192-SR1)
 - 10GBASE-S (model number: XFP-10G-S)
 - 10GBASE-Z (model number: XFP-10G-Z-OC192-LR2)

Optical interface specifications—see [“10-Gigabit Ethernet 10GBASE Optical Interface Specifications” on page 54](#)

- DWDM Tunable XFP transceivers:
 - Connector: Duplex LC/PC (Rx and Tx)
 - 10GBASE-ZR (model number: XFP-10G-CBAND-T50-ZR)
DWDM supported wavelengths—see [10-Gigabit Ethernet DWDM Transceiver Wavelengths](#)

NOTE: XFP-10G-CBAND-T50-ZR is supported in Junos OS Release 10.2 and later

Optical interface specifications—see [“10-Gigabit Ethernet 10GBASE Optical Interface Specifications” on page 54](#)

LEDs

OK/FAIL LED, one bicolor:

- Steady green—DPC is functioning normally.
- Blinking green—DPC is transitioning online or offline.
- Red—DPC has failed.

LINK LED, one green per port:

- Off—No link.
- On steadily—Link is active.

TUNNEL LED, one green per XFP port:

- Off—Normal operating mode.
- On steadily—Port configured in tunnel mode.

The SFP Link LEDs are labeled in groups of five:

- 0/0 for 0/0 through 0/4
- 0/5 for 0/5 through 0/9
- 1/0 for 1/0 through 1/4
- 1/5 for 1/5 through 1/9

The XFP ports are labeled top to bottom 2/0 and 3/0.

**Related
Documentation**

- [MX Series DPC Overview on page 7](#)
- [DPCs Supported on MX240, MX480, and MX960 Routers on page 7](#)
- [Gigabit Ethernet 1000BASE Optical Interface Specifications on page 44](#)
- [Fast Ethernet and Gigabit Ethernet Bidirectional SFP Optical Interface Specifications on page 50](#)
- [10-Gigabit Ethernet 10GBASE Optical Interface Specifications on page 54](#)

Multiservices DPC

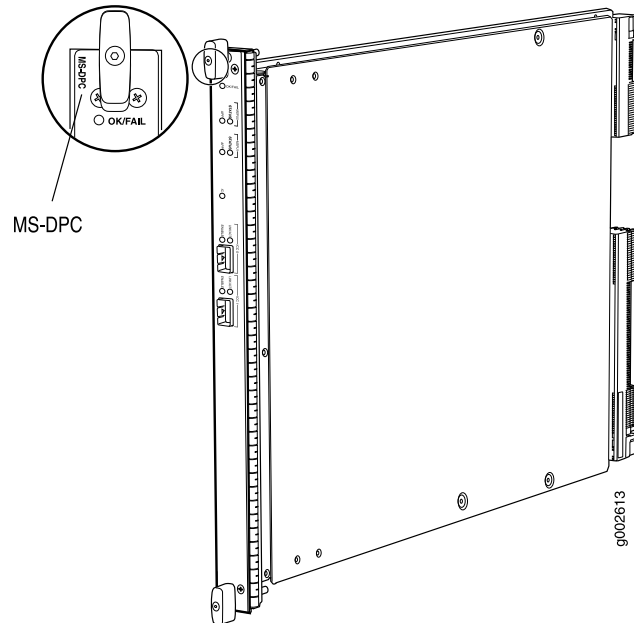

Software release	<ul style="list-style-type: none"> Junos OS Release 9.3 and later
Description	<ul style="list-style-type: none"> Power requirement: 5.52 A @ 48 V (265 W) Weight: 14.7 lb (6.7 kg) Supports tunnel services. This feature is included with the DPC and does not require an individual license. Individual licenses must be purchased for additional services. Supports large Ethernet frame sizes for more efficient throughput across the intra-POP network The maximum number of supported MS-DPCs is as follows except where noted in "Protocols and Applications Supported by the Multiservices DPC (MS-DPC)" on page 317: <ul style="list-style-type: none"> MX240 router: 2 MX480 router: 4 MX960 router: 6 Model number: MS-DPC
Hardware features	<ul style="list-style-type: none"> Active monitoring on up to 10 million flows Maximum transmission units (MTUs) of up to 9192 bytes Two Multiservices Processing Units (MSPUs) per DPC, which include two 1.1Ghz multicore CPUs, each with 4GB of memory for processing integrated services
Software features	<ul style="list-style-type: none"> Support for up to 12,000 service sets See "Protocols and Applications Supported by the Multiservices DPC (MS-DPC)" on page 317 for information about the protocols and applications that this DPC supports.

Interfaces Syntax: *mediatype-fpc/pic/port* where:

- mediatype: gr, pc, pd, etc
- fpc: Slot in the router where the MPC is installed
- pic: 0 or 1
- port: 0

NOTE: Port number reflects the internal interface and is not a physical port.

Cables and connectors • SFPs are not supported.

LEDs **OK/FAIL** LED, one bicolor:

- Steady green—DPC is functioning normally.
- Blinking green—DPC is transitioning online or offline.
- Red—DPC has failed.

STATUS LED, one tricolor per MSPU:

- Off—MSPU is offline. If both MSPUs are offline it is safe to remove the DPC from the chassis.
- Green—MSPU is operating normally.
- Yellow—MSPU is initializing.
- Red—MSPU has an error or failure.

Application (**APP**) LED, one tricolor per MSPU:

- Off—Service is not running on the MSPU.
- Green—Service is running on the MSPU under acceptable load.
- Yellow—Service on the MSPU is overloaded.

-
- Related Documentation**
- [MX Series DPC Overview on page 7](#)
 - [DPCs Supported on MX240, MX480, and MX960 Routers on page 7](#)

Tri-Rate Enhanced DPC

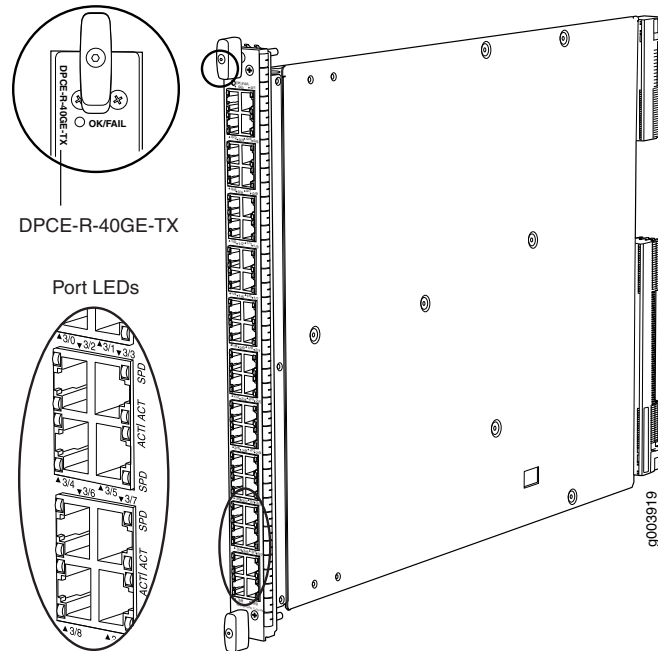

Software release	<ul style="list-style-type: none"> Junos OS Release 9.1 and later
Description	<ul style="list-style-type: none"> 40 autonegotiating 10BASE-T, 100BASE-TX, or 1000BASE-T Megabit Ethernet ports Power requirement: 6.67 A @ 48 V (320 W) Weight: 14.5 lb (6.6 kg) Supports large Ethernet frame sizes for more efficient throughput across the intra-POP network Model number: DPCE-R-40GE-TX Name in the CLI: DPCE 40x 1GE R TX
Hardware features	<ul style="list-style-type: none"> High-performance throughput on each port at speeds of 10 Mbps, 100 Mbps, or 1000 Mbps Autonegotiation between Gigabit Ethernet circuit partners Full-duplex mode Maximum transmission units (MTUs) of up to 9192 bytes Enhanced ASICs for increased performance and scalability of Layer 2 features There are four sets of 10 ports labeled: <ul style="list-style-type: none"> 0/0 through 0/9 1/0 through 1/9 2/0 through 2/9 3/0 through 3/9
Software features	<ul style="list-style-type: none"> See “Protocols and Applications Supported by DPCs and Enhanced DPCs (DPC and DPCE-R)” on page 297 for information about the protocols and applications that this DPC supports.

Interfaces	<p>Syntax: <i>ge-fpc/pic/port</i> where:</p> <ul style="list-style-type: none"> • fpc: Slot in the router where the DPC is installed • pic: Grouping of 10-ports, numbered 0 through 3 • port: 0 through 9 <p>For example, <i>ge-1/3/0</i> is the interface for port 0 (labeled 3/0) in the right-most grouping of ports on a DPC installed in slot 1.</p>
------------	--

Cables and connectors	<ul style="list-style-type: none"> • Connector: Four-pair, Category 5 shielded twisted-pair connectivity through an RJ-45 connector • Pinout: <ul style="list-style-type: none"> • Junos OS Release 9.1: MDI • Junos OS Release 9.2 and later: MDI, MDI crossover • Maximum distance: 328 ft/100 m <p>CAUTION: Do not use RJ-45 cables with strain-relief boots exceeding 1.5 mm from the bottom of the connector. Cable boots that exceed this measurement can damage the port.</p>
-----------------------	---

LEDs	<p>OK/FAIL LED, one bicolor:</p> <ul style="list-style-type: none"> • Steady green—DPC is functioning normally. • Blinking green—DPC is transitioning online or offline. • Red—DPC has failed. <p>ACT LED, one green per port:</p> <ul style="list-style-type: none"> • Off—No active traffic. • Blinking—Link is active. <p>SPD LED, one bicolor:</p> <ul style="list-style-type: none"> • Green—DPC is functioning in 1000BASE-T mode. • Yellow—DPC is functioning in 10BASE-T or 100BASE-TX mode. • Off—No link. <p>The ACT and SPD LEDs are located on either side of the ports labeled horizontally and top to bottom 0/0 through 3/9.</p>
------	--

Related Documentation	<ul style="list-style-type: none"> • MX Series DPC Overview on page 7 • DPCs Supported on MX240, MX480, and MX960 Routers on page 7
------------------------------	---

Tri-Rate Enhanced Ethernet Services DPC

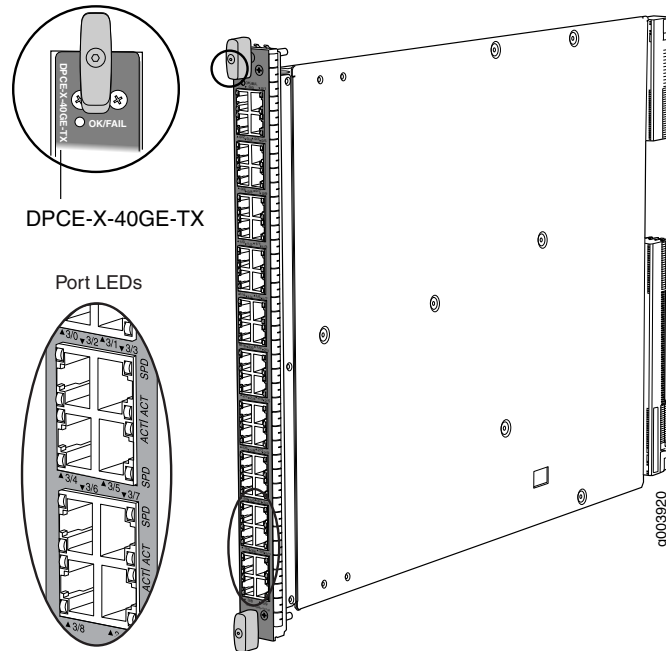

Software release	<ul style="list-style-type: none"> Junos OS Release 9.1 and later EOL (see PSN-2009-06-400)
Description	<ul style="list-style-type: none"> 40 autonegotiating 10BASE-T, 100.BASE-TX, or 1000BASE-T Megabit Ethernet ports Power requirement: 6.67 A @ 48 V (320 W) Weight: 14.5 lb (6.6 kg) Supports large Ethernet frame sizes for more efficient throughput across the intra-POP network Model number: DPCE-X-40GE-TX Name in the CLI:
Hardware features	<ul style="list-style-type: none"> High-performance throughput on each port at speeds of 10 Mbps, 100 Mbps, or 1000 Mbps Autonegotiation between Gigabit Ethernet circuit partners Full-duplex mode Maximum transmission units (MTUs) of up to 9192 bytes Enhanced ASICs for increased performance and scalability of Layer 2 features
Software features	<ul style="list-style-type: none"> See "Protocols and Applications Supported by Enhanced Ethernet Services DPCs (DPCE-X)" on page 303 for information about the protocols and applications that this DPC supports.
Interfaces	<p>Syntax: <i>ge-fpc/pic/port</i> where:</p> <ul style="list-style-type: none"> fpc: Slot in the router where the DPC is installed pic: Grouping of 10-ports, numbered 0 through 3 port: 0 through 9 <p>For example, <i>ge-1/3/0</i> is the interface for port 0 (labeled 3/0) in the right-most grouping of ports on a DPC installed in slot 1.</p>

- Cables and connectors
- Connector: Four-pair, Category 5 shielded twisted-pair connectivity through an RJ-45 connector
 - Pinout:
 - Junos OS Release 9.1: MDI
 - Junos OS Release 9.2 and later: MDI, MDI crossover
 - Maximum distance: 328 ft/100 m

CAUTION: Do not use RJ-45 cables with strain-relief boots exceeding 1.5 mm from the bottom of the connector. Cable boots that exceed this measurement can damage the port.

LEDs

OK/FAIL LED, one bicolor:

- Steady green—DPC is functioning normally.
- Blinking green—DPC is transitioning online or offline.
- Red—DPC has failed.

ACT LED, one green per port:

- Off—No active traffic.
- Blinking—Link is active.

SPD LED, one bicolor:

- Green—DPC is functioning in 1000BASE-T mode.
- Yellow—DPC is functioning in 10BASE-T or 100BASE-TX mode.
- Off—No link.

The **ACT** and **SPD** LEDs are located on either side of the ports labeled horizontally and top to bottom 0/0 through 3/9.

**Related
Documentation**

- [MX Series DPC Overview on page 7](#)
- [DPCs Supported on MX240, MX480, and MX960 Routers on page 7](#)

CHAPTER 8

MX Series MPC Descriptions

- 16x10GE MPC on page 134
- Multiservices MPC on page 136
- MPC1 on page 138
- MPC1E on page 139
- MPC1 Q on page 141
- MPC1E Q on page 143
- MPC2 on page 145
- MPC2E on page 147
- MPC2 Q on page 149
- MPC2E Q on page 151
- MPC2 EQ on page 153
- MPC2E EQ on page 155
- MPC2E P on page 157
- MPC2E NG on page 159
- MPC2E NG Q on page 161
- MPC3E on page 163
- MPC3E NG on page 165
- MPC3E NG Q on page 167
- 32x10GE MPC4E on page 169
- 2x100GE + 8x10GE MPC4E on page 171
- 6x40GE + 24x10GE MPC5E on page 173
- 6x40GE + 24x10GE MPC5EQ on page 175
- 2x100GE + 4x10GE MPC5E on page 177
- 2x100GE + 4x10GE MPC5EQ on page 179
- MPC6E on page 181
- MPC7E (Multi-Rate) on page 182
- MPC7E 10G on page 185

- [MPC8E on page 186](#)
- [MPC9E on page 188](#)

16x10GE MPC

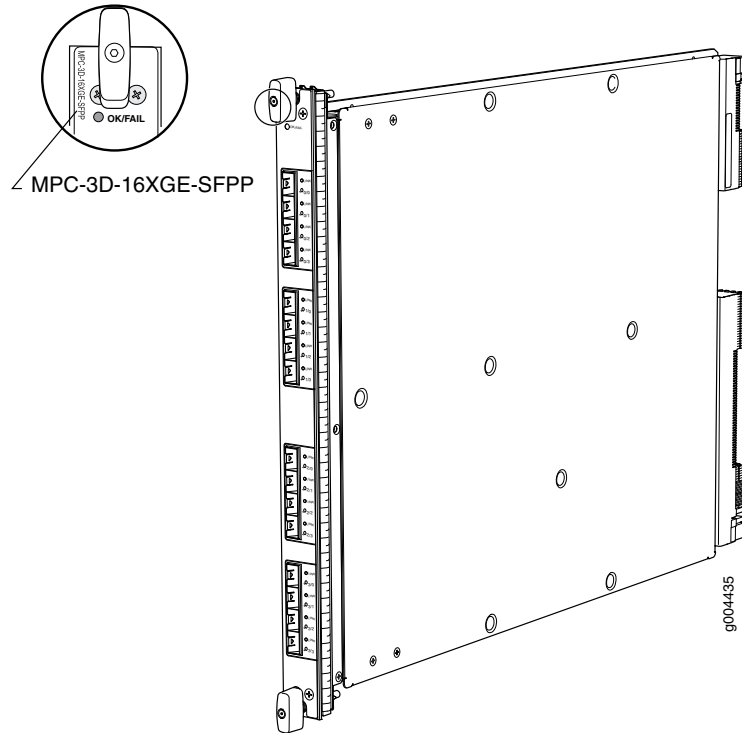

Software release	<ul style="list-style-type: none"> • MX240, MX480, and MX960 routers : Junos OS Release 10.0R2 and later • MX2010 and MX2020 router: Junos OS Release 12.3 and later
Description	<ul style="list-style-type: none"> • Fixed configuration MPC with sixteen 10-Gigabit Ethernet ports • Power requirement: 9.17 A @ 48 V (440 W) • Weight: 18.35 lb (8.3 kg) • Model numbers: <ul style="list-style-type: none"> • MPC-3D-16XGE-SFPP • MPC-3D-16XGE-SFPP-R-B • Name in the CLI: <ul style="list-style-type: none"> • MPC 3D 16x10GE • MPC 3D 16x10GE EM
Hardware features	<ul style="list-style-type: none"> • High-performance throughput on each port at speeds up to 10 Gbps • Four fully programmable Junos Trio chipsets for increased scaling for bandwidth, subscribers, and services • One Junos Trio chipset per set of four ports • LAN-PHY mode at 10.3125 Gbps <p>NOTE: The 16x10GE 3D MPC does not support WAN-PHY mode.</p>

Software features	<ul style="list-style-type: none"> • Optical diagnostics and related alarms • See “Protocols and Applications Supported by MX240, MX480, MX960, MX2010, and MX2020 MPCs” on page 319 for information about the protocols and applications that this MPC supports.
-------------------	---

Interfaces	<p>Syntax: <code>xe-fpc/pic/port</code> where:</p> <ul style="list-style-type: none"> • fpc: Slot in the router where the MPC is installed • pic: Grouping of 4 ports, numbered 0 through 3 • port: 0 through 3 <p>For example, <code>xe-1/3/3</code> is the interface for the last port (labeled 3/3) on an MPC installed in slot 1.</p>
------------	---

Cables and connectors	<ul style="list-style-type: none"> • 10-Gigabit SFP+ transceivers: <ul style="list-style-type: none"> • Connector: Duplex LC (Rx and Tx) • 10GBASE-ER (model number: SFPP-10GE-ER) • 10GBASE-LR (model number: SFPP-10GE-LR) • 10GBASE-LRM (model number: SFPP-10GE-LRM) • 10GBASE-SR (model number: SFPP-10GE-SR) • 10GBASE-Z: <ul style="list-style-type: none"> • Model number SFPP-10GE-ZR is supported in Junos OS Release 12.2 and later • Model number SFPP-10G-CT50-ZR for MPC-3D-16XGE-SFPP: <ul style="list-style-type: none"> • Is supported in Junos OS Release 12.3R6, 13.2R3, 13.3R2, and 14.1, and later • Supports LAN-PHY mode <p>NOTE: The 16x10GE 3D MPC does not support WAN-PHY mode.</p> • Is tunable by configuring the wavelength statement at the [edit interfaces interface-name optics-options] hierarchy level (see <i>wavelength</i>) • Model number SFPP-10G-OTN-XT: <ul style="list-style-type: none"> • Supported in Junos OS Release 12.3R5, 13.2R3, 13.3, and later • NEBS compliant • Dual-rate extended temperature transceiver that supports LAN-PHY mode and OTN rates <p>NOTE: The 16x10GE 3D MPC does not support WAN-PHY mode.</p> • Model number SFPP-10G-DT-ZRC2 for MPC-3D-16XGE-SFPP: <ul style="list-style-type: none"> • Is supported in Junos OS Release 12.3R8, 13.2R5, 13.3R3, 14.1R2, 14.2, and later • Supports LAN-PHY mode <p>NOTE: The 16x10GE 3D MPC does not support WAN-PHY mode.</p> • Is tunable by configuring the wavelength statement at the [edit interfaces interface-name optics-options] hierarchy level (see <i>wavelength</i>) • NEBS compliant <p>Optical interface specifications—see “10-Gigabit Ethernet 10GBASE Optical Interface Specifications” on page 54</p>
-----------------------	---

LEDs

OK/FAIL LED, one bicolor:

- Steady green—MPC is functioning normally.
- Blinking green—MPC is transitioning online or offline.
- Red—MPC has failed.

Enable/disable LED, one bicolor per port:

- Green—Port is enabled.
- Yellow—Port is not functioning normally.
- Off—Port is disabled.

The enable/disable LEDs are labeled in groups of four:

- 0/0 through 0/3
- 1/0 through 1/3
- 2/0 through 2/3
- 3/0 through 3/3

Related Documentation

- [MX Series MPC Overview on page 11](#)
- [MPCs Supported by MX240, MX480, MX960, MX2010, and MX2020 Routers on page 12](#)

Multiservices MPC

Figure 6: Multiservices MPC

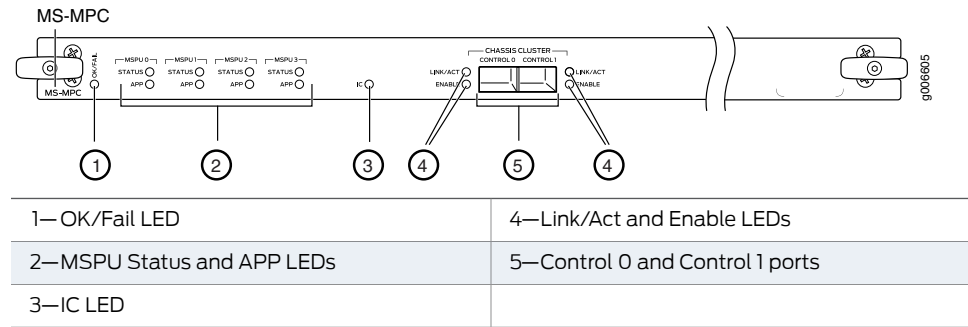

Software release

- Junos OS Release 13.2R4 and later

For information on which MPCs are supported on MX Series routers, see [“MPCs Supported by MX240, MX480, MX960, MX2010, and MX2020 Routers” on page 12](#).

Description

- Power requirement: 12.2 Amps @ 48 V (590W)
- Weight: 14 lbs.
- Model number: MS-MPC
- Name in the CLI: **MS-MPC**

Hardware features

- One Junos Trio chipset for increased scaling for bandwidth, subscribers, and services.

Software features	<ul style="list-style-type: none"> • Support for up to 6000 service sets. • Support for MTUs up to 9192 bytes. • See “Protocols and Applications Supported by the MS-MIC and MS-MPC” on page 387 for information about the protocols and applications that this MPC supports.
-------------------	--

LEDs	<p>OK/FAIL LED, one bicolor:</p> <ul style="list-style-type: none"> • Steady green—MPC is functioning normally. • Blinking green—MPC is transitioning online or offline. • Red—MPC has failed. <p>IC LED—Reserved for future use.</p> <p>STATUS LED, one tricolor per MSPU:</p> <ul style="list-style-type: none"> • Off—MSPU is offline. If both MSPUs are offline it is safe to remove the DPC from the chassis. • Green—MSPU is operating normally. • Yellow—MSPU is initializing. • Red—MSPU has an error or failure. <p>Application (APP) LED, one tricolor per MSPU:</p> <ul style="list-style-type: none"> • Off—Service is not running on the MSPU. • Green—Service is running on the MSPU under acceptable load. • Yellow—Service on the MSPU is reconfiguring. • Red—Service on the MSPU has failed. <p>Activity (LINK/ACT) LED, one per control port:</p> <ul style="list-style-type: none"> • Off—No link. • Green—Chassis cluster control port link is active. <p>ENABLE LED, one per control port:</p> <ul style="list-style-type: none"> • Off—Chassis cluster control port is disabled. • Green—Chassis cluster control port is enabled.
------	--

Related Documentation	<ul style="list-style-type: none"> • MX Series MPC Overview on page 11 • Multiservices MIC on page 253 • Protocols and Applications Supported by the MS-MIC and MS-MPC on page 387
------------------------------	---

MPC1

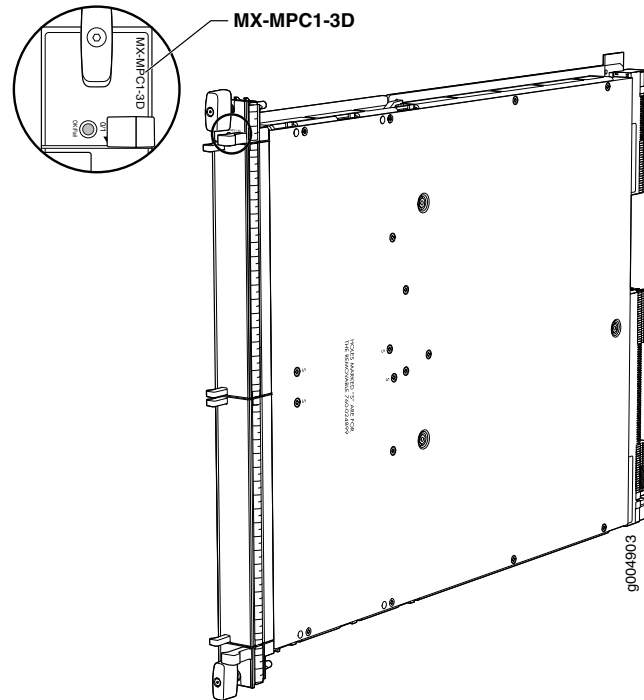

Software release	<ul style="list-style-type: none"> MX240, MX480, and MX960 routers: Junos OS Release 10.2 and later MX2010 and MX2020 router: Junos OS Release 12.3 and later <p>For information on which MICs are supported on this MPC, "MIC/MPC Compatibility" on page 21.</p>
Description	<ul style="list-style-type: none"> Power requirement: 3.4 A @ 48 V (165 W) Weight: 13.8 lb (6.3 kg) Model number: MX-MPC1-3D Name in the CLI: MPC Type 1 3D
Hardware features	<ul style="list-style-type: none"> Two slots for MICs labeled PIC 0/1 and PIC 2/3 One Junos Trio chipset for increased scaling for bandwidth, subscribers, and services LAN-PHY mode at 10.3125 Gbps WAN-PHY mode at 9.953 Gbps
Software features	<ul style="list-style-type: none"> See "Protocols and Applications Supported by MX240, MX480, MX960, MX2010, and MX2020 MPCs" on page 319 for information about the protocols and applications that this MPC supports.
LEDs	<p>OK/FAIL LED, one bicolor:</p> <ul style="list-style-type: none"> Steady green—MPC is functioning normally. Blinking green—MPC is transitioning online or offline. Red—MPC has failed.

- Related Documentation**
- [MX Series MPC Overview on page 11](#)
 - [MPCs Supported by MX240, MX480, MX960, MX2010, and MX2020 Routers on page 12](#)

MPC1E

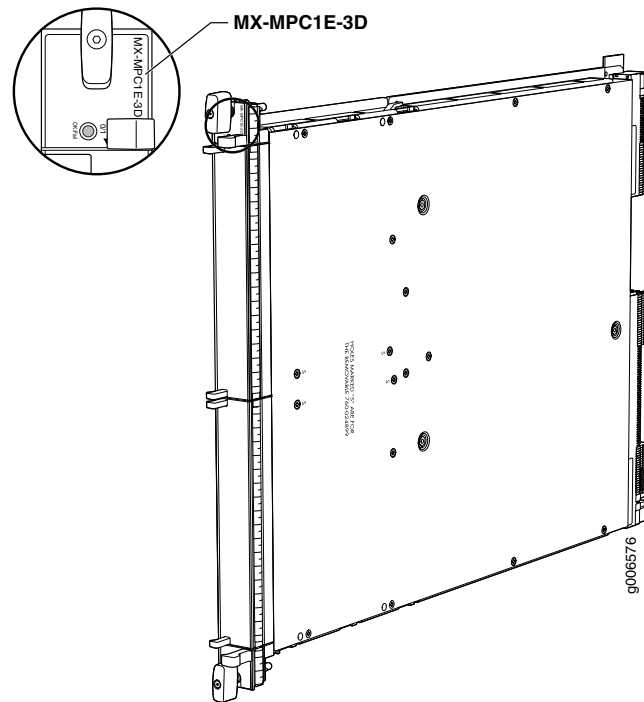

Software release	<ul style="list-style-type: none"> • MX240, MX480, and MX960 routers: Junos OS Release 11.2R4 and later • MX2010 and MX2020 router: Junos OS Release 12.3 and later <p>For information on which MICs are supported on this MPC, “MIC/MPC Compatibility” on page 21.</p>
Description	<ul style="list-style-type: none"> • Power requirement: 3.4 A @ 48 V (165 W) • Weight: 13.8 lb (6.3 kg) • Model number: MX-MPC1E-3D • Name in the CLI: MPCE Type 1 3D
Hardware features	<ul style="list-style-type: none"> • Two slots for MICs labeled PIC 0/1 and PIC 2/3 • One Junos Trio chipset for increased scaling for bandwidth, subscribers, and services • LAN-PHY mode at 10.3125 Gbps • WAN-PHY mode at 9.953 Gbps
Software features	<ul style="list-style-type: none"> • See “Protocols and Applications Supported by MX240, MX480, MX960, MX2010, and MX2020 MPC1Es” on page 328 for information about the protocols and applications that this MPC supports.

LEDs

OK/FAIL LED, one bicolor:

- Steady green—MPC is functioning normally.
 - Blinking green—MPC is transitioning online or offline.
 - Red—MPC has failed.
-

- Related Documentation**
- [MX Series MPC Overview on page 11](#)
 - [MPCs Supported by MX240, MX480, MX960, MX2010, and MX2020 Routers on page 12](#)

MPC1 Q

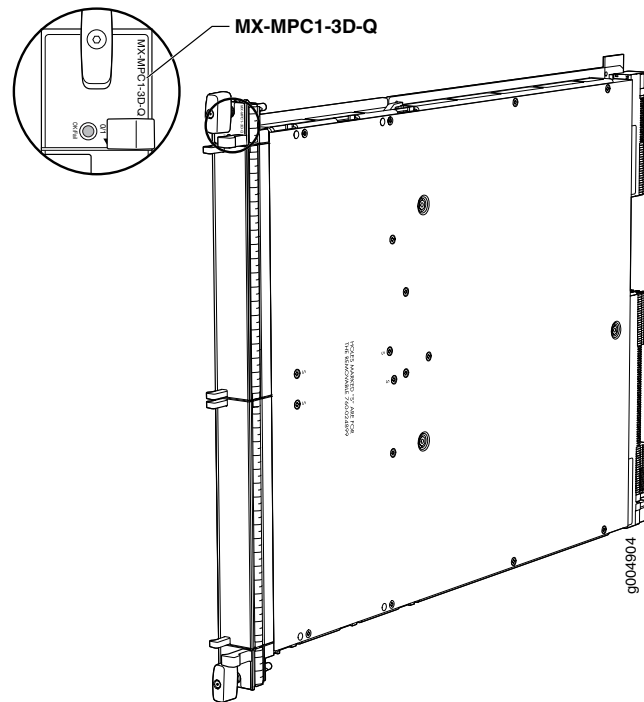

Software release	<ul style="list-style-type: none"> • MX240, MX480, and MX960 routers: Junos OS Release 10.2 and later • MX2010 and MX2020 router: Junos OS Release 12.3 and later <p>For information on which MICs are supported on this MPC, “MIC/MPC Compatibility” on page 21.</p>
Description	<ul style="list-style-type: none"> • Power requirement: 3.65 A @ 48 V (175 W) • Weight: 13.8 lb (6.3 kg) • Model number: MX-MPC1-3D-Q • Name in the CLI: MPC Type 1 3D Q
Hardware features	<ul style="list-style-type: none"> • Two slots for MICs labeled PIC 0/1 and PIC 2/3 • One Junos Trio chipset for increased scaling for bandwidth, subscribers, and services • LAN-PHY mode at 10.3125 Gbps • WAN-PHY mode at 9.953 Gbps
Software features	<ul style="list-style-type: none"> • See “Protocols and Applications Supported by MX240, MX480, MX960, MX2010, and MX2020 MPCs” on page 319 for information about the protocols and applications that this MPC supports.

LEDs

OK/FAIL LED, one bicolor:

- Steady green—MPC is functioning normally.
 - Blinking green—MPC is transitioning online or offline.
 - Red—MPC has failed.
-

- Related Documentation**
- [MX Series MPC Overview on page 11](#)
 - [MPCs Supported by MX240, MX480, MX960, MX2010, and MX2020 Routers on page 12](#)

MPC1E Q

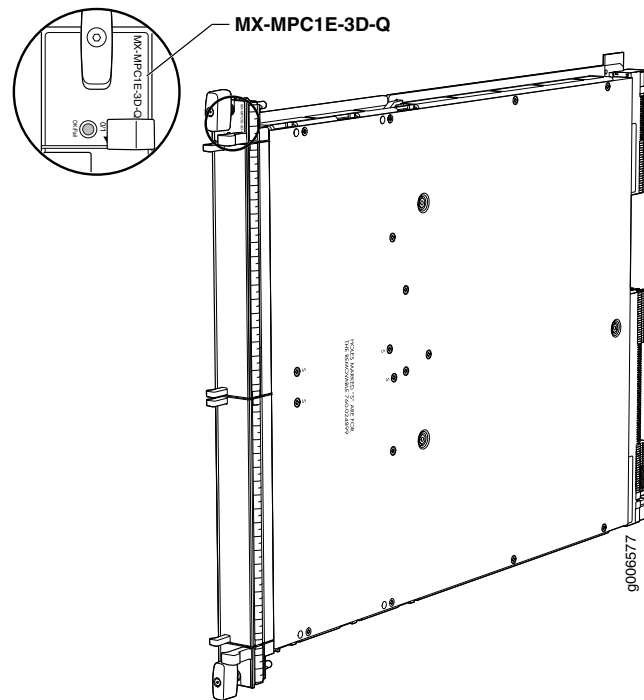

Software release	<ul style="list-style-type: none"> • MX240, MX480, and MX960 routers: Junos OS Release 11.2R4 and later • MX2010 and MX2020 router: Junos OS Release 12.3 and later <p>For information on which MICs are supported on this MPC, “MIC/MPC Compatibility” on page 21.</p>
Description	<ul style="list-style-type: none"> • Power requirement: 3.65 A @ 48 V (175 W) • Weight: 13.8 lb (6.3 kg) • Model number: MX-MPC1E-3D-Q • Name in the CLI: MPCE Type 1 3D Q
Hardware features	<ul style="list-style-type: none"> • Two slots for MICs labeled PIC 0/1 and PIC 2/3 • One Junos Trio chipset for increased scaling for bandwidth, subscribers, and services • LAN-PHY mode at 10.3125 Gbps • WAN-PHY mode at 9.953 Gbps
Software features	<ul style="list-style-type: none"> • See “Protocols and Applications Supported by MX240, MX480, MX960, MX2010, and MX2020 MPC1Es” on page 328 for information about the protocols and applications that this MPC supports.

LEDs

OK/FAIL LED, one bicolor:

- Steady green—MPC is functioning normally.
 - Blinking green—MPC is transitioning online or offline.
 - Red—MPC has failed.
-

- Related Documentation**
- [MX Series MPC Overview on page 11](#)
 - [MPCs Supported by MX240, MX480, MX960, MX2010, and MX2020 Routers on page 12](#)

MPC2

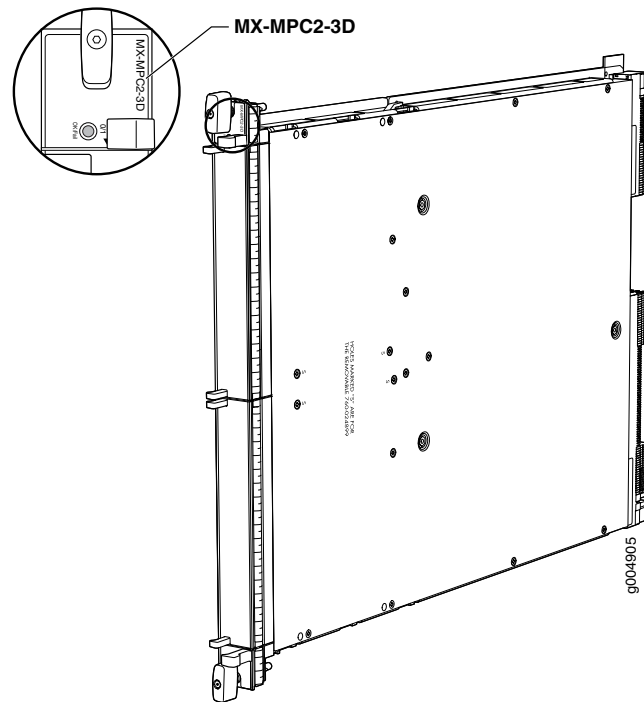

Software release	<ul style="list-style-type: none"> • MX240, MX480, and MX960 routers : Junos OS Release 10.1 and later • MX2010 and MX2020 router: Junos OS Release 12.3 and later <p>For information on which MICs are supported on this MPC, "MIC/MPC Compatibility" on page 21.</p>
Description	<ul style="list-style-type: none"> • Power requirement: 5.7 A @ 48 V (274 W) • Weight: 14 lb (6.4 kg) • Model number: MX-MPC2-3D • Name in the CLI: MPC Type 2 3D
Hardware features	<ul style="list-style-type: none"> • Two slots for MICs labeled PIC 0/1 and PIC 2/3 • Two Junos Trio chipsets for increased scaling for bandwidth, subscribers, and services • LAN-PHY mode at 10.3125 Gbps • WAN-PHY mode at 9.953 Gbps
Software features	<ul style="list-style-type: none"> • See "Protocols and Applications Supported by MX240, MX480, MX960, MX2010, and MX2020 MPCs" on page 319 for information about the protocols and applications that this MPC supports.

LEDs

OK/FAIL LED, one bicolor:

- Steady green—MPC is functioning normally.
 - Blinking green—MPC is transitioning online or offline.
 - Red—MPC has failed.
-

- Related Documentation**
- [MX Series MPC Overview on page 11](#)
 - [MPCs Supported by MX240, MX480, MX960, MX2010, and MX2020 Routers on page 12](#)

MPC2E

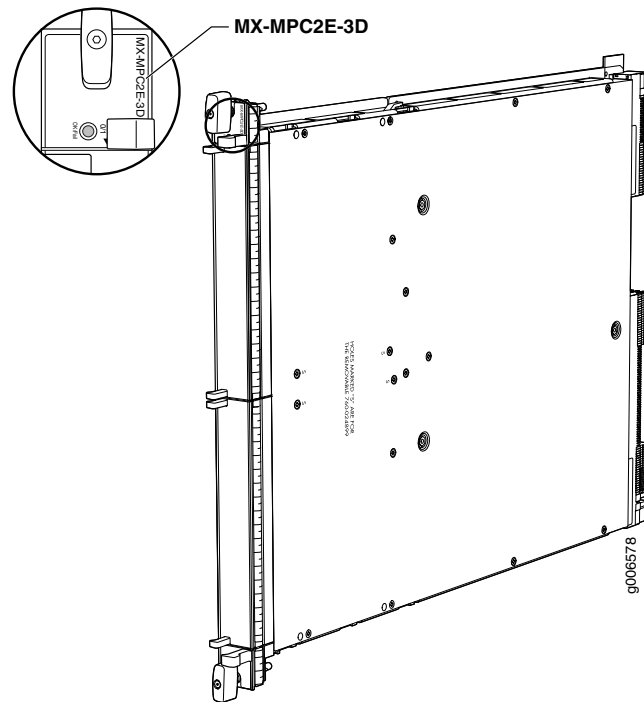

Software release	<ul style="list-style-type: none"> • MX240, MX480, and MX960 routers : Junos OS Release 11.2R4 and later • MX2010 and MX2020 router: Junos OS Release 12.3 and later <p>For information on which MICs are supported on this MPC, "MIC/MPC Compatibility" on page 21.</p>
Description	<ul style="list-style-type: none"> • Power requirement: 5.7 A @ 48 V (274 W) • Weight: 14 lb (6.4 kg) • Model number: MX-MPC2E-3D • Name in the CLI: MPCE Type 2 3D
Hardware features	<ul style="list-style-type: none"> • Two slots for MICs labeled PIC 0/1 and PIC 2/3 • Two Junos Trio chipsets for increased scaling for bandwidth, subscribers, and services • LAN-PHY mode at 10.3125 Gbps • WAN-PHY mode at 9.953 Gbps
Software features	<ul style="list-style-type: none"> • See "Protocols and Applications Supported by MX240, MX480, MX960, MX2010, and MX2020 MPCIEs" on page 328 for information about the protocols and applications that this MPC supports.

LEDs

OK/FAIL LED, one bicolor:

- Steady green—MPC is functioning normally.
 - Blinking green—MPC is transitioning online or offline.
 - Red—MPC has failed.
-

- Related Documentation**
- [MX Series MPC Overview on page 11](#)
 - [MPCs Supported by MX240, MX480, MX960, MX2010, and MX2020 Routers on page 12](#)

MPC2 Q

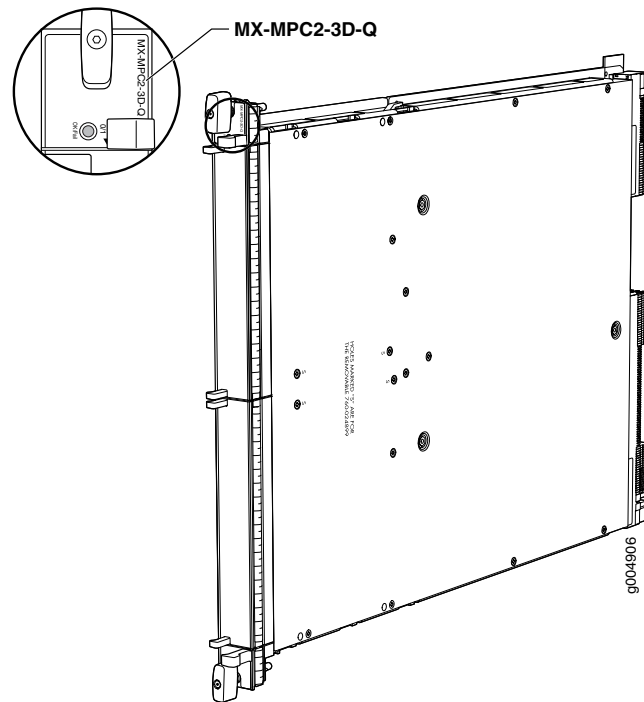

Software release	<ul style="list-style-type: none"> • MX240, MX480, and MX960 routers : Junos OS Release 10.1 and later • MX2010 and MX2020 router: Junos OS Release 12.3 and later <p>For information on which MICs are supported on this MPC, “MIC/MPC Compatibility” on page 21.</p>
Description	<ul style="list-style-type: none"> • Power requirement: 6.13 A @ 48 V (294 W) • Weight: 14 lb (6.4 kg) • Model number: MX-MPC2-3D-Q • Name in the CLI: MPC Type 2 3D Q
Hardware features	<ul style="list-style-type: none"> • Two slots for MICs labeled PIC 0/1 and PIC 2/3 • Two Junos Trio chipsets for increased scaling for bandwidth, subscribers, and services • LAN-PHY mode at 10.3125 Gbps • WAN-PHY mode at 9.953 Gbps
Software features	<ul style="list-style-type: none"> • See “Protocols and Applications Supported by MX240, MX480, MX960, MX2010, and MX2020 MPCs” on page 319 for information about the protocols and applications that this MPC supports.

LEDs

OK/FAIL LED, one bicolor:

- Steady green—MPC is functioning normally.
 - Blinking green—MPC is transitioning online or offline.
 - Red—MPC has failed.
-

- Related Documentation**
- [MX Series MPC Overview on page 11](#)
 - [MPCs Supported by MX240, MX480, MX960, MX2010, and MX2020 Routers on page 12](#)

MPC2E Q

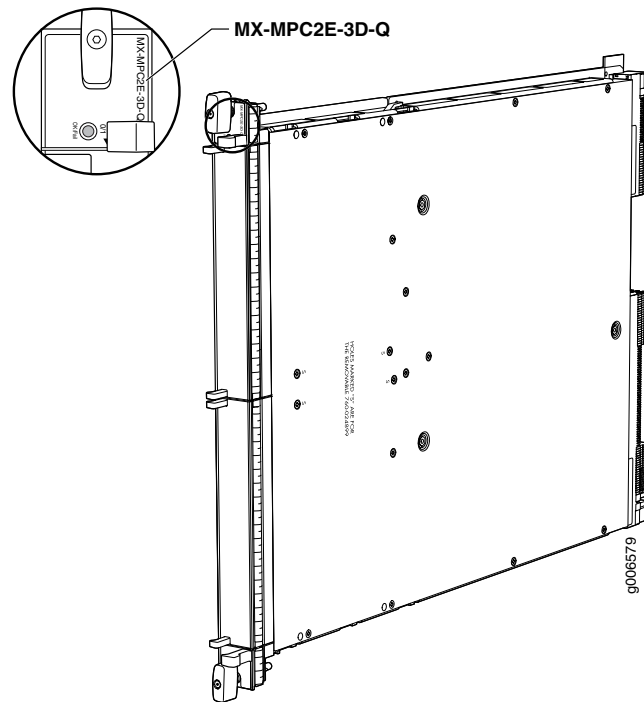

Software release	<ul style="list-style-type: none"> • MX240, MX480, and MX960 routers : Junos OS Release 11.2R4 and later • MX2010 and MX2020 router: Junos OS Release 12.3 and later <p>For information on which MICs are supported on this MPC, "MIC/MPC Compatibility" on page 21.</p>
Description	<ul style="list-style-type: none"> • Power requirement: 6.13 A @ 48 V (294 W) • Weight: 14 lb (6.4 kg) • Model number: MX-MPC2E-3D-Q • Name in the CLI: MPCE Type 2 3D Q
Hardware features	<ul style="list-style-type: none"> • Two slots for MICs labeled PIC 0/1 and PIC 2/3 • Two Junos Trio chipsets for increased scaling for bandwidth, subscribers, and services • LAN-PHY mode at 10.3125 Gbps • WAN-PHY mode at 9.953 Gbps
Software features	<ul style="list-style-type: none"> • See "Protocols and Applications Supported by MX240, MX480, MX960, MX2010, and MX2020 MPCIEs" on page 328 for information about the protocols and applications that this MPC supports.

LEDs

OK/FAIL LED, one bicolor:

- Steady green—MPC is functioning normally.
 - Blinking green—MPC is transitioning online or offline.
 - Red—MPC has failed.
-

- Related Documentation**
- [MX Series MPC Overview on page 11](#)
 - [MPCs Supported by MX240, MX480, MX960, MX2010, and MX2020 Routers on page 12](#)

MPC2 EQ

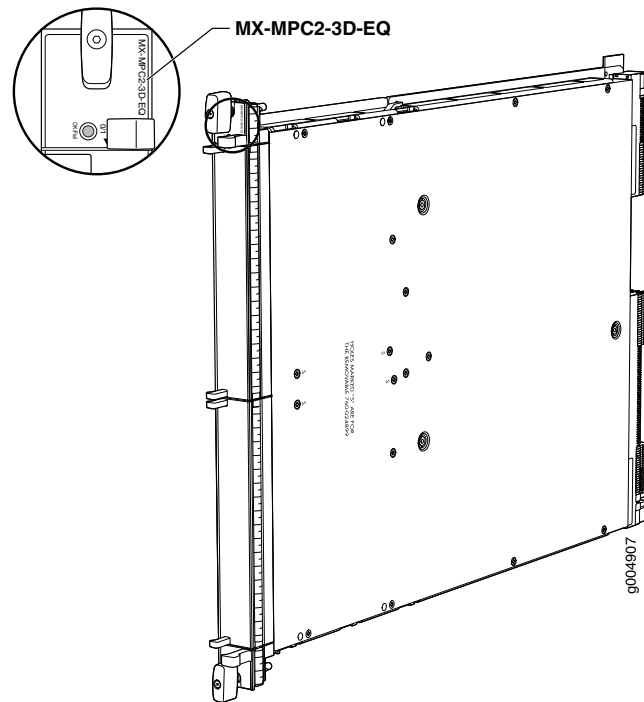

Software release	<ul style="list-style-type: none"> • MX240, MX480, and MX960 routers : Junos OS Release 10.1 and later • MX2010 and MX2020 router: Junos OS Release 12.3 and later <p>For information on which MICs are supported on this MPC, “MIC/MPC Compatibility” on page 21.</p>
Description	<ul style="list-style-type: none"> • Power requirement: 6.13 A @ 48 V (294 W) • Weight: 14 lb (6.4 kg) • Model number: MX-MPC2-3D-EQ • Name in the CLI: MPC Type 2 3D EQ
Hardware features	<ul style="list-style-type: none"> • Two slots for MICs labeled PIC 0/1 and PIC 2/3 • Two Junos Trio chipsets for increased scaling for bandwidth, subscribers, and services • LAN-PHY mode at 10.3125 Gbps • WAN-PHY mode at 9.953 Gbps
Software features	<ul style="list-style-type: none"> • See “Protocols and Applications Supported by MX240, MX480, MX960, MX2010, and MX2020 MPCs” on page 319 for information about the protocols and applications that this MPC supports.

LEDs

OK/FAIL LED, one bicolor:

- Steady green—MPC is functioning normally.
 - Blinking green—MPC is transitioning online or offline.
 - Red—MPC has failed.
-

- Related Documentation**
- [MX Series MPC Overview on page 11](#)
 - [MPCs Supported by MX240, MX480, MX960, MX2010, and MX2020 Routers on page 12](#)

MPC2E EQ

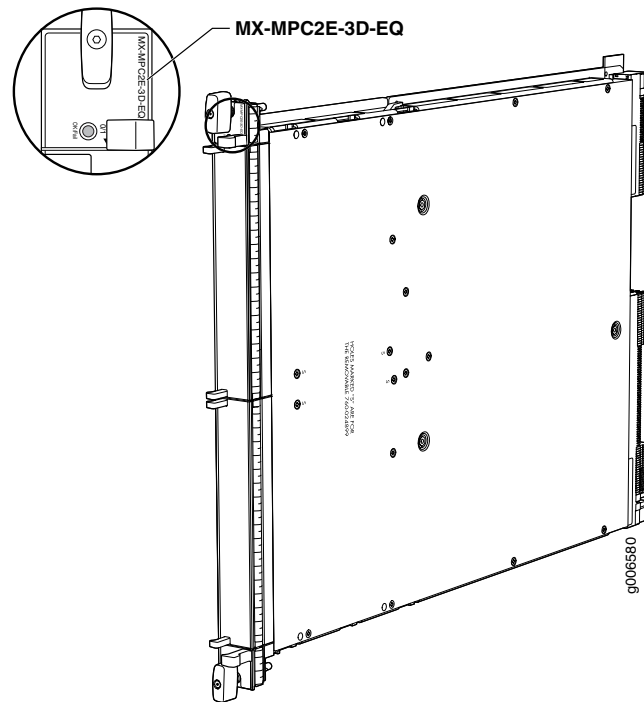

Software release	<ul style="list-style-type: none"> • MX240, MX480, and MX960 routers : Junos OS Release 11.2R4 and later • MX2010 and MX2020 router: Junos OS Release 12.3 and later <p>For information on which MICs are supported on this MPC, “MIC/MPC Compatibility” on page 21.</p>
Description	<ul style="list-style-type: none"> • Power requirement: 6.13 A @ 48 V (294 W) • Weight: 14 lb (6.4 kg) • Model number: MX-MPC2E-3D-EQ • Name in the CLI: MPCE Type 2 3D EQ
Hardware features	<ul style="list-style-type: none"> • Two slots for MICs labeled PIC 0/1 and PIC 2/3 • Two Junos Trio chipsets for increased scaling for bandwidth, subscribers, and services • LAN-PHY mode at 10.3125 Gbps • WAN-PHY mode at 9.953 Gbps
Software features	<ul style="list-style-type: none"> • See “Protocols and Applications Supported by MX240, MX480, MX960, MX2010, and MX2020 MPCIEs” on page 328 for information about the protocols and applications that this MPC supports.

LEDs

OK/FAIL LED, one bicolor:

- Steady green—MPC is functioning normally.
 - Blinking green—MPC is transitioning online or offline.
 - Red—MPC has failed.
-

- Related Documentation**
- [MX Series MPC Overview on page 11](#)
 - [MPCs Supported by MX240, MX480, MX960, MX2010, and MX2020 Routers on page 12](#)

MPC2E P

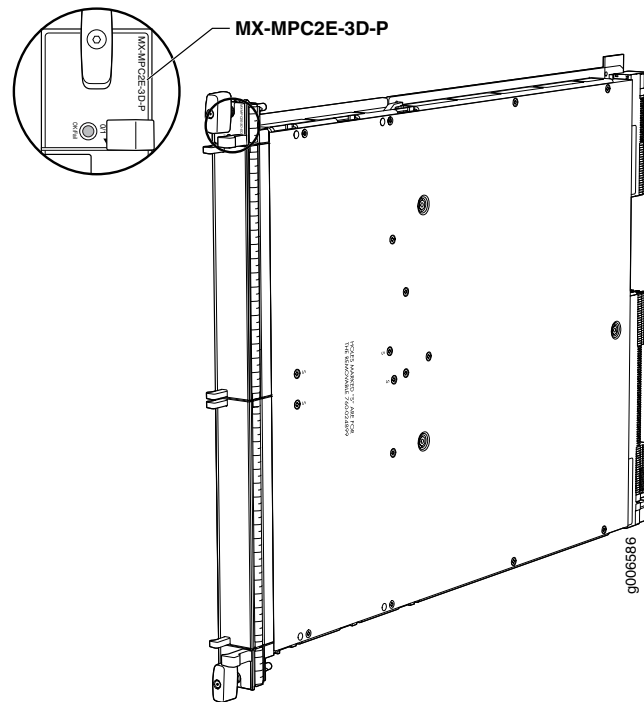

Software release	<ul style="list-style-type: none"> • MX240, MX480, and MX960 routers : Junos OS Release 12.2 and later • MX2010 and MX2020 router: Junos OS Release 12.3 and later <p>For information on which MICs are supported on this MPC, "MIC/MPC Compatibility" on page 21.</p>
Description	<ul style="list-style-type: none"> • Power requirement: 6.13 A @ 48 V (294 W) • Weight: 14 lb (6.4 kg) • Model number: MX-MPC2E-3D-P • Name in the CLI: MPCE Type 2 3D P
Hardware features	<ul style="list-style-type: none"> • Two slots for MICs labeled PIC 0/1 and PIC 2/3 • Two Junos Trio chipsets for increased scaling for bandwidth, subscribers, and services • LAN-PHY mode at 10.3125 Gbps • WAN-PHY mode at 9.953 Gbps
Software features	<ul style="list-style-type: none"> • See "Protocols and Applications Supported by MX240, MX480, MX960, MX2010, and MX2020 MPCIEs" on page 328 for information about the protocols and applications that this MPC supports.

LEDs

OK/FAIL LED, one bicolor:

- Steady green—MPC is functioning normally.
 - Blinking green—MPC is transitioning online or offline.
 - Red—MPC has failed.
-

- Related Documentation**
- [MX Series MPC Overview on page 11](#)
 - [MPCs Supported by MX240, MX480, MX960, MX2010, and MX2020 Routers on page 12](#)

MPC2E NG

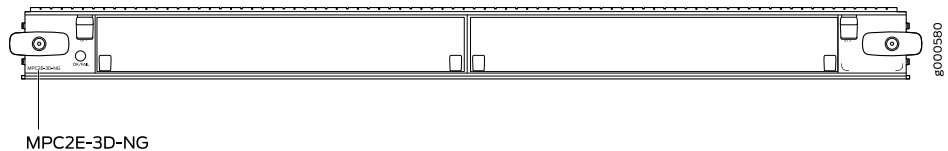

Software release	<ul style="list-style-type: none"> • Junos OS releases 14.1R4, 14.2R3 with Junos Continuity, Junos OS release 15.1 and later <p>For information about which MICs are supported on this MPC, see “MIC/MPC Compatibility” on page 21.</p>
Description	<ul style="list-style-type: none"> • 80 Gbps capacity without hierarchical quality of service (HQoS) • Requires high-capacity fan trays and high-capacity filter trays • Weight: 15.96 lb (7.26 kg) • Model numbers: MPC2E-3D-NG • Name in the CLI: MPC2E NG PQ & Flex Q • Add-on license provides limited additional flexible queuing. <p>NOTE: MPC2E-3D-NG is not compatible with SCB, you must use either SCBE-MX or SCBE2-MX for the switch fabric interface.</p>
Hardware features	<ul style="list-style-type: none"> • Line-rate throughput of up to 80 Gbps • Supports WAN-PHY mode at 9.95 Gbps and LAN-PHY mode at 10.31 Gbps • Two slots for MICs • Junos Trio chipsets for increased scaling for bandwidth, subscribers, and services. <p>NOTE: MPC2E-3D-NG does not support MIC3-3D-10XGE-SFPP, MIC3-3D-1X100GE-CFP, MIC3-3D-1X100GE-CXP, and MIC3-3D-2X40GE-QSFPP.</p> <p>NOTE: The non-HQoS MPC3E NG and MPC2E NG MPCs support MIC-3D-8CHOC3-4CHOC12 and MIC-3D-4CHOC3-2CHOC12 only with a limited queuing license.</p>
Software features	<ul style="list-style-type: none"> • Chained composite next hops • Layer 3 VPN localization • Detection of Layer 2 loops • Entropy label support in mixed mode • SNMP and CLI support for Routing Engine memory monitoring • Mixed-mode LAG support on core interfaces • Dynamic power management for MICs • Support for flexible-queuing <p>• See “Protocols and Applications Supported by MX240, MX480, MX960, MX2010, and MX2020 MPC2E” on page 334 for information about the protocols and applications that this MPC supports.</p>

Power requirement Maximum with highest-power MICs at 55° C: 9.88 A @ 48 V (474 W)

At different temperatures:

- 55° C: 474 W
- 40° C: 417 W
- 25° C: 400 W

LEDs

OK/FAIL LED, one bicolor:

- Steady green—MPC is functioning normally.
- Blinking green—MPC is transitioning online or offline.
- Red—MPC has failed.

- Related Documentation**
- [MX Series MPC Overview on page 11](#)
 - [MPCs Supported by MX240, MX480, MX960, MX2010, and MX2020 Routers on page 12](#)
 - [Junos Continuity Software](#)

MPC2E NG Q

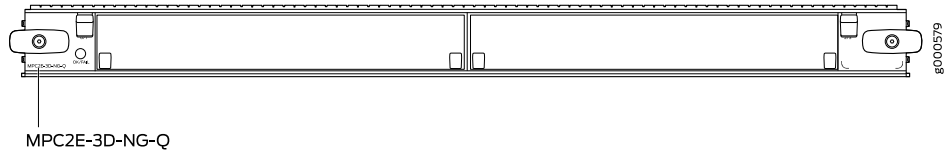

Software release	<ul style="list-style-type: none"> • Junos OS releases 14.1R4, 14.2R3 with Junos Continuity, Junos OS release 15.1 and later <p>For information about which MICs are supported on this MPC, see "MIC/MPC Compatibility" on page 21.</p>
Description	<ul style="list-style-type: none"> • 80 Gbps capacity with hierarchical quality of service (HQoS) • Requires high-capacity fan trays and high capacity filter trays • Weight: 15.96 lb (7.26 kg) • Model number: MPC2E-3D-NG-Q • Name in the CLI: MPC2E NG HQoS <p>NOTE: MPC2E-3D-NG-Q is not compatible with SCB, you must use either SCBE-MX or SCBE2-MX for the switch fabric interface.</p>
Hardware features	<ul style="list-style-type: none"> • Line-rate throughput of up to 80 Gbps • Supports up to 512,000 queues per slot • Supports WAN-PHY mode at 9.95 Gbps and LAN-PHY mode at 10.31 Gbps • Two slots for MICs • Junos Trio chipsets for increased scaling for bandwidth, subscribers, and services. <p>NOTE: MPC2E-3D-NG-Q does not support MIC3-3D-10XGE-SFPP, MIC3-3D-1X100GE-CFP, MIC3-3D-1X100GE-CXP, and MIC3-3D-2X40GE-QSFPP.</p>
Software features	<ul style="list-style-type: none"> • Chained composite next hops • Layer 3 VPN localization • Detection of Layer 2 loops • Entropy label support in mixed mode • SNMP and CLI support for Routing Engine memory monitoring • BFD support for inline MLPPP/MLFR • Mixed Mode LAG support on core interfaces • Dynamic power management for MICs • See "Protocols and Applications Supported by MX240, MX480, MX960, MX2010, and MX2020 MPC2E" on page 334 for information about the protocols and applications that this MPC supports.

Power requirement Maximum with highest-power MICs at 55° C: 11.02 A @ 48 V (529 W)

At different temperatures:

- 55° C: 529 W
- 40° C: 460 W
- 25° C: 438 W

LEDs

OK/FAIL LED, one bicolor:

- Steady green—MPC is functioning normally.
- Blinking green—MPC is transitioning online or offline.
- Red—MPC has failed.

- Related Documentation**
- [MX Series MPC Overview on page 11](#)
 - [MPCs Supported by MX240, MX480, MX960, MX2010, and MX2020 Routers on page 12](#)
 - [Junos Continuity Software](#)

MPC3E

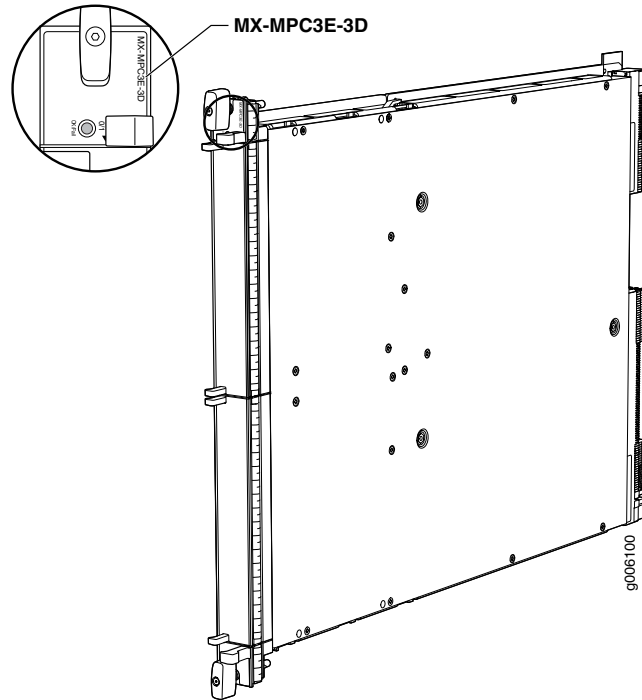

Software release	<ul style="list-style-type: none"> • MX240, MX480, and MX960 routers : Junos OS Release 12.1 and later • MX2010 and MX2020 router: Junos OS Release 12.3 and later <p>For information on which MICs are supported on this MPC, "MIC/MPC Compatibility" on page 21.</p>
Description	<ul style="list-style-type: none"> • Power requirement: 10.83 A @ 48 V (440 W; plus 40 W for each of the two MICs) • Requires high-capacity fan trays • Weight: 14.94 lb (6.78 kg) • Model number: MX-MPC3E-3D • Name in the CLI: MPCE Type 3 3D
Hardware features	<ul style="list-style-type: none"> • Two slots for MICs • Chipset for increased scaling for bandwidth, subscribers, and services
Software features	<ul style="list-style-type: none"> • See "Protocols and Applications Supported by the MX240, MX480, MX960, MX2010, and MX2020 MPC3E" on page 343 for information about the protocols and applications that this MPC supports.

LEDs

OK/FAIL LED, one bicolor:

- Steady green—MPC is functioning normally.
 - Blinking green—MPC is transitioning online or offline.
 - Red—MPC has failed.
-

- Related Documentation**
- [MX Series MPC Overview on page 11](#)
 - [MPCs Supported by MX240, MX480, MX960, MX2010, and MX2020 Routers on page 12](#)

MPC3E NG

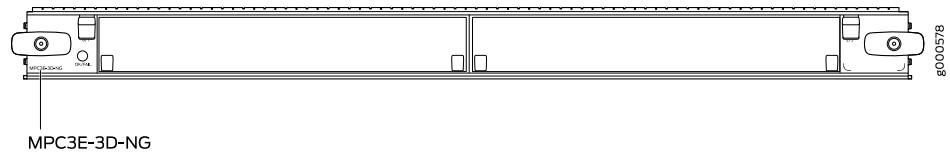

Software release	<ul style="list-style-type: none"> • Junos OS releases 14.1R4, 14.2R3 with Junos Continuity, Junos OS release 15.1 and later <p>For information about which MICs are supported on this MPC, see “MIC/MPC Compatibility” on page 21.</p>
Description	<ul style="list-style-type: none"> • 130 Gbps capacity without hierarchical quality of service (HQoS) • Requires high-capacity fan trays and high-capacity filter trays • Weight: 15.96 lb (7.26 kg) • Model number: MPC3E-3D-NG • Name in the CLI: MPC3E NG PQ & Flex Q • Add-on license provides limited additional flexible queuing. <p>NOTE: MPC3E-3D-NG is not compatible with SCB, you must use either SCBE-MX or SCBE2-MX for the switch fabric interface.</p>
Hardware features	<ul style="list-style-type: none"> • Line-rate throughput of up to 130 Gbps • Supports WAN-PHY mode at 9.95 Gbps and LAN-PHY mode at 10.31 Gbps • Two slots for MICs • Junos Trio chipsets for increased scaling for bandwidth, subscribers, and services <p>NOTE: The non-HQOS MPC3E NG and MPC2E NG MPCs support MIC-3D-8CHOC3-4CHOC12 and MIC-3D-4CHOC3-2CHOC12 only with a limited queuing license.</p>
Software features	<ul style="list-style-type: none"> • Chained composite next hops • Layer 3 VPN localization • Detection of Layer 2 loops • Entropy label support in mixed mode • SNMP and CLI support for Routing Engine memory monitoring • Mixed Mode LAG support on core interfaces • Dynamic power management for MICs • Support for flexible-queuing • See “Protocols and Applications Supported by the MX240, MX480, MX960, MX2010, and MX2020 MPC3E” on page 343 for information about the protocols and applications that this MPC supports.

Power requirement Maximum with highest-power MICs at 55° C: 11.13 A @ 48 V (534 W)

At different temperatures:

- 55° C: 534 W
- 40° C: 485 W
- 25° C: 461 W

LEDs

OK/FAIL LED, one bicolor:

- Steady green—MPC is functioning normally.
- Blinking green—MPC is transitioning online or offline.
- Red—MPC has failed.



NOTE: On the MX960 router, FPC slot 0 and slot 11 are not NEBS compliant beyond 104°F (40°C) with MPC3E-3D-NG and MPC3E-3D-NG-Q. This is a cooling restriction.

- Related Documentation**
- [MX Series MPC Overview on page 11](#)
 - [MPCs Supported by MX240, MX480, MX960, MX2010, and MX2020 Routers on page 12](#)
 - [Junos Continuity Software](#)

MPC3E NG Q

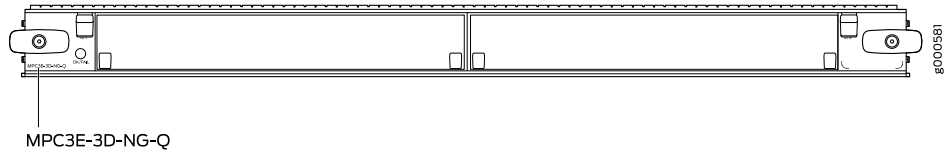

Software release	<ul style="list-style-type: none"> • Junos OS releases 14.1R4, 14.2R3 with Junos Continuity, Junos OS release 15.1 and later <p>For information about which MICs are supported on this MPC, see "MIC/MPC Compatibility" on page 21.</p>
Description	<ul style="list-style-type: none"> • 130 Gbps capacity with hierarchical quality of service (HQoS) • Requires high-capacity fan trays and high-capacity filter trays • Weight: 15.96 lb (7.26 kg) • Model number: MPC3E-3D-NG-Q • Name in the CLI: MPC3E NG HQoS <p>NOTE: MPC3E-3D-NG-Q is not compatible with SCB, you must use either SCBE-MX or SCBE2-MX for the switch fabric interface.</p>
Hardware features	<ul style="list-style-type: none"> • Line-rate throughput of up to 130 Gbps • Supports up to 512,000 queues per slot • Supports WAN-PHY mode at 9.95 Gbps and LAN-PHY mode at 10.31 Gbps • Two slots for MICs • Junos Trio chipsets for increased scaling for bandwidth, subscribers, and services
Software features	<ul style="list-style-type: none"> • Chained composite next hops • Layer 3 VPN localization • Detection of Layer 2 loops • Entropy label support in mixed mode • SNMP and CLI support for Routing Engine memory monitoring • BFD support for inline MLPPP/MLFR • Mixed Mode LAG support on core interfaces • Dynamic power management for MICs • See "Protocols and Applications Supported by the MX240, MX480, MX960, MX2010, and MX2020 MPC3E" on page 343 for information about the protocols and applications that this MPC supports.

Power requirement Maximum with highest-power MICs at 55° C: 12.15 A @ 48 V (583 W)

At different temperatures:

- 55° C: 583 W
- 40° C: 532 W
- 25° C: 503 W

LEDs

OK/FAIL LED, one bicolor:

- Steady green—MPC is functioning normally.
- Blinking green—MPC is transitioning online or offline.
- Red—MPC has failed.



NOTE: On the MX960 router, FPC slot 0 and slot 11 are not NEBS compliant beyond 104°F (40°C) with MPC3E-3D-NG and MPC3E-3D-NG-Q. This is a cooling restriction.

- Related Documentation**
- [MX Series MPC Overview on page 11](#)
 - [MPCs Supported by MX240, MX480, MX960, MX2010, and MX2020 Routers on page 12](#)
 - [Junos Continuity Software](#)

32x10GE MPC4E

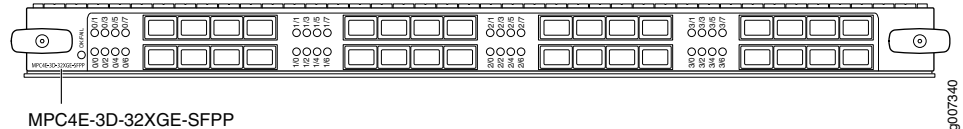

Software release	<ul style="list-style-type: none"> • Junos OS Release 12.3R2 and later
Description	<ul style="list-style-type: none"> • Fixed configuration MPC with thirty-two 10-Gigabit Ethernet ports • Power requirement: 12.7 A @ 48 V (610 W) • Weight: 19.4 lb (8.8 kg) • Model number: MPC4E-3D-32XGE-SFPP
Hardware features	<ul style="list-style-type: none"> • Line-rate throughput of up to 260 Gbps • WAN-PHY mode at 10 Gbps on a per-port basis • Supported on MX2020, MX2010, MX960, MX480, and MX240 routers with both normal-capacity and high-capacity power supplies and fan trays.
Software features	<ul style="list-style-type: none"> • Optical diagnostics and related alarms • Up to 260 Gbps of full-duplex traffic • Intelligent oversubscription services • Configurable LAN-PHY and WAN-PHY mode options per port • Local loopback • Configurable to interoperate with routers that use the 100-Gigabit Ethernet PIC (Type 4 PIC on Type 4 FPC) • See “Protocols and Applications Supported by the MX240, MX480, MX960, MX2010, and MX2020 MPC4Es” on page 351 for information about the protocols and applications that this MPC supports.

- Cables and connectors
- Fiber-optic 10-gigabit small form-factor pluggable (SFP+) transceivers:
 - Connector: Duplex LC
 - 10GBASE-SR (model number: SFPP-10GE-SR)
 - 10GBASE-LR (model number: SFPP-10GE-LR)
 - 10GBASE-ER (model number: SFPP-10GE-ER-XT)
 - 10GBASE-ZR (model number: SFPP-10GE-ZR)

NOTE: SFPP-10GE-ZR has a commercial temperature rating and is not NEBS compliant when plugged into the 32x10GE MPC4E with SFP+. If the ambient air temperature exceeds 40°C, Junos OS disables the transmitter, which takes the optical transceiver offline.

 - 10GBASE-ZR (model number: SFPP-10G-OTN-XT)
 - Supported in Junos OS Release 12.3R5, 13.2R3, 13.3, and later
 - NEBS compliant
 - Dual-rate extended temperature transceiver that supports LAN-PHY and WAN-PHY modes, and OTN rates
 - 10GBASE-ZR (model number: SFPP-10G-DT-ZRC2)
 - Supported in Junos OS Release 12.3R6, 13.2R3, 13.3R2, 14.1R1, and later
 - Supports LAN-PHY and WAN-PHY modes
 - Is tunable by configuring the **wavelength** statement at the **[edit interfaces interface-name optics-options]** hierarchy level (see *wavelength*)

NOTE: SFPP-10G-DT-ZRC2 is not NEBS compliant when plugged into the MPC4E-3D-32XGE-SFPP MPC. If the ambient air temperature exceeds 40°C, Junos OS disables the transmitter, which takes the optical transceiver offline.

Optical interface specifications—see “[10-Gigabit Ethernet 10GBASE Optical Interface Specifications](#)” on page 54.

NOTE: On the MX960 router, FPC slot 0 and FPC slot 11 are not NEBS compliant beyond 104°F (40°C). This is a cooling restriction.

LEDs

OK/FAIL LED, one bicolor:

- Steady green—MPC is functioning normally.
- Blinking green—MPC is transitioning online or offline.
- Red—MPC has failed.

Enable/disable LED, one bicolor per port:

- Green—Port is enabled.
- Red—Port has failed.
- Off—Port is disabled.

The enable/disable LEDs are arranged in four groups:

- 0/0 through 0/7
- 1/0 through 1/7
- 2/0 through 2/7
- 3/0 through 3/7

Related Documentation

- [MX Series MPC Overview on page 11](#)
- [MPC4E on MX Series Routers Overview](#)
- [MPCs Supported by MX240, MX480, MX960, MX2010, and MX2020 Routers on page 12](#)

- *Configuring MPC4E (MPC4E-3D-2CGE-8XGE) to Interoperate with 100-Gigabit Ethernet PICs on Type 4 FPC Using SA Multicast Mode*

2x100GE + 8x10GE MPC4E

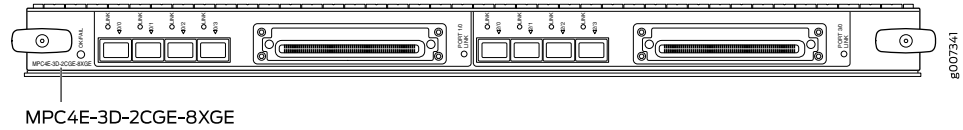

Software release	<ul style="list-style-type: none"> • Junos OS Release 12.3R2 and later
Description	<ul style="list-style-type: none"> • Fixed configuration MPC with two 100-Gigabit Ethernet ports and eight 10-Gigabit Ethernet ports • Power requirement: 12.7 A @ 48 V (610 W) • Weight: 19.4 lb (8.8 kg) • Model number: MPC4E-3D-2CGE-8XGE
Hardware features	<ul style="list-style-type: none"> • Line-rate throughput of up to 260 Gbps • WAN-PHY mode at 10 Gbps on a per-port basis • Supported only on the MX960, MX480, and MX240 routers with high-capacity power supplies and high-capacity fan trays. • The ports are labeled as: <ul style="list-style-type: none"> • 10-Gigabit Ethernet ports: 0/0 through 0/3 • 100-Gigabit Ethernet ports: PORT 1/0 • 10-Gigabit Ethernet ports: 2/0 through 2/3 • 100-Gigabit Ethernet ports: PORT 3/0
Software features	<ul style="list-style-type: none"> • Optical diagnostics and related alarms • Configurable LAN-PHY and WAN-PHY mode options per 10-Gigabit Ethernet port • Up to 260 Gbps of full-duplex traffic • Intelligent oversubscription services • Local loopback • Configurable to interoperate with routers that use the 100-Gigabit Ethernet PIC (Type 4 PIC on Type 4 FPC) • See "Protocols and Applications Supported by the MX240, MX480, MX960, MX2010, and MX2020 MPC4Es" on page 351 for information about the protocols and applications that this MPC supports.

Cables and connectors

- Fiber-optic 10-gigabit small form-factor pluggable (SFP+) transceivers:
 - Connector: Duplex LC
 - 10GBASE-SR (model number: SFPP-10GE-SR)
 - 10GBASE-LR (model number: SFPP-10GE-LR)
 - 10GBASE-ER (model number: SFPP-10GE-ER-XT)
 - 10GBASE-ZR (model number: SFPP-10GE-ZR)

NOTE: SFPP-10GE-ZR has a commercial temperature rating and is not NEBS compliant when plugged into the 2x100GE + 8x10GE MPC4E. If the ambient air temperature exceeds 40°C, Junos OS disables the transmitter, which takes the optical transceiver offline.

 - 10GBASE-ZR (model number: SFPP-10G-OTN-XT)
 - Supported in Junos OS Release 12.3R5, 13.2R3, 13.3, and later
 - NEBS compliant
 - Dual-rate extended temperature transceiver that supports LAN-PHY and WAN-PHY modes and OTN rates
 - 10GBASE-ZR (model number: SFPP-10G-DT-ZRC2)
 - Supported in Junos OS Release 12.3R6, 13.2R3, 13.3R2, 14.1R1, and later
 - Supports LAN-PHY and WAN-PHY modes
 - Is tunable by configuring the **wavelength** statement at the **[edit interfaces interface-name optics-options]** hierarchy level (see *wavelength*)

NOTE: SFPP-10G-DT-ZRC2 is not NEBS compliant when plugged into the MPC4E-3D-2CGE-8XGE MPC. If the ambient air temperature exceeds 40°C, Junos OS disables the transmitter, which takes the optical transceiver offline.

Optical interface specifications—see “[10-Gigabit Ethernet 10GBASE Optical Interface Specifications](#)” on page 54.

- 100-Gigabit Ethernet CFP transceivers:
 - 100GBASE-SR10 (model number: CFP-100GBASE-SR10)
 - 100GBASE-LR4 (model number: CFP-100GBASE-LR4)
 - GEN2-100GBASE-LR4 (model number: CFP-GEN2-100GBASE-LR4 and part number: 740-047682)
 - 100GBASE-ER4 (model number: CFP-GEN2-CGE-ER4 and part number: 740-049763). Connector: Duplex LC
 - 100GBASE-ZR (model number: CFP-100GBASE-ZR)
 - Supported in Junos OS Release 13.3R6, 14.1R4, 14.2R3, and 15.1R1 and later
 - Provides advanced dual polarization-quadrature phase-shift keying (DP-QPSK) coherent digital signal processing (DSP) and forward error correction (FEC)-enabled robust tolerance to optical impairments and supports 80 km reach over single mode fiber
 - The transceiver is not specified as part of IEEE 802.3 but is built according to Juniper Networks specifications.

NOTE: The “GEN2” optics have been redesigned with newer versions of internal components for reduced power consumption.

NOTE: CFP-100GBASE-LR4 and CFP-100GBASE-ZR are not NEBS compliant when plugged into the 2x100GE + 8x10GE MPC4E. If the ambient air temperature exceeds 40°C, the software disables the transmitter, which takes the optical transceiver offline.

Optical interface specifications—see “[100-Gigabit Ethernet 100GBASE-R Optical Interface Specifications](#)” on page 68.

NOTE: On the MX960 router, FPC slot 0 and FPC slot 11 are not NEBS compliant beyond 104°F (40°C). This is a cooling restriction.

LEDs	<p>OK/FAIL LED, one bicolor:</p> <ul style="list-style-type: none"> Steady green—MPC is functioning normally. Blinking green—MPC is transitioning online or offline. Red—MPC has failed. <p>LINK LED, one tricolor per port:</p> <ul style="list-style-type: none"> Green—Port is enabled. Red—Port has failed. Yellow—Port is disabled by configuration. Off—Port is disabled.
------	--

Related Documentation	<ul style="list-style-type: none"> MX Series MPC Overview on page 11 MPC4E on MX Series Routers Overview MPCs Supported by MX240, MX480, MX960, MX2010, and MX2020 Routers on page 12 Configuring MPC4E (MPC4E-3D-2CGE-8XGE) to Interoperate with 100-Gigabit Ethernet PICs on Type 4 FPC Using SA Multicast Mode
------------------------------	---

6x40GE + 24x10GE MPC5E

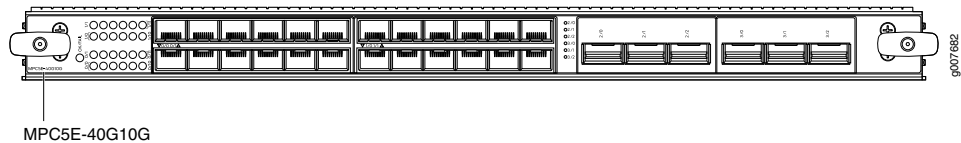

Software release	<ul style="list-style-type: none"> Junos OS Release 13.3R2 and later
Description	<ul style="list-style-type: none"> Fixed-port MPC with six 40-Gigabit Ethernet ports and twenty-four 10-Gigabit Ethernet ports Weight: 21 lb (9.52 kg) Model number: MPC5E-40G10G Name in the CLI: MPC5E 3D 24XGE+6XLGE
Hardware features	<ul style="list-style-type: none"> Line-rate throughput of up to 240 Gbps Supports up to 32,000 queues per-slot LAN-PHY mode at 10.3125 Gbps on a per-port basis WAN-PHY mode at 9.95328 Gbps on a per-port basis The ports are labeled as: <ul style="list-style-type: none"> 10-Gigabit Ethernet ports: <ul style="list-style-type: none"> 0/0 through 0/11 1/0 through 1/11 40-Gigabit Ethernet ports: <ul style="list-style-type: none"> 2/0 through 2/2 3/0 through 3/2

NOTE: On MX960 routers, all the MPC slots work with the ambient temperature of up to 40° C. However, when the chassis temperature exceeds 40° C, slots 0 and 11 can work with MPC1s, MPC2s, and the 16x10GE MPC.

Software features

- Optical diagnostics and related alarms
- Two packet-forwarding engines, PFE0 and PFE1. PFE0 hosts PIC0 and PIC2. PFE1 hosts PIC1 and PIC3.
- Configurable LAN-PHY and WAN-PHY mode options per 10-Gigabit Ethernet port
- See ["Protocols and Applications Supported by the MX240, MX480, MX960, MX2010, and MX2020 MPC5Es" on page 358](#) for information about the protocols and applications that this MPC supports.

NOTE: On MX240, MX480, and MX960 routers, MPC5E powers on only if the **network-services** mode on the router is configured to either **enhanced-ip** or **enhanced-ethernet**. On MX2010 and MX2020 routers, only **enhanced-ip** is supported.

NOTE: A maximum of two PICs can be powered on at any one time (PIC0 or PIC2, and PIC1 or PIC3). The other PICs must be powered off.

Cables and connectors

- Fiber-optic 40-gigabit quad small form-factor pluggable plus (QSFP+)
 - 40GBASE-SR4 (model number: QSFP-40GBASE-SR4)
Connector: 12-fiber MPO
 - 40GBASE-LR4 (model number: QSFP-40GBASE-LR4)
Connector: Standard Duplex LC

Optical interface specifications—see ["40-Gigabit Ethernet 40GBASE-R Optical Interface Specifications" on page 64](#).

- 40GBASE-LX4 (model number: QSFP-40GE-LX4)
Connector: Standard Duplex LC

NOTE: QSFP-40GE-LX4 is not NEBS compliant on the MX960 router in FPC slot 0 or FPC slot 11.

- Fiber-optic 10-gigabit small form-factor pluggable (SFP+) transceivers:
 - Connector: Duplex LC
 - 10GBASE-SR (model number: SFPP-10GE-SR)
 - 10GBASE-LR (model number: SFPP-10GE-LR)
 - 10GBASE-ER (model number: SFPP-10GE-ER-XT)
 - 10GBASE-Z (model number: SFPP-10G-ZR-OTN-XT)

Optical interface specifications—see ["10-Gigabit Ethernet 10GBASE Optical Interface Specifications" on page 54](#).

Power requirements

- Typical: 9.68 A @ 48 V (460 W)
- At different temperatures:
 - 55° C: 607 W
 - 40° C: 541 W
 - 25° C: 511 W

LEDs

OK/FAIL LED, one bicolor:

- Steady green—MPC is functioning normally.
- Blinking green—MPC is transitioning online or offline.
- Red—MPC has failed.

10-Gigabit Ethernet **LINK LED**, one green per port:

- Green—Link is up.
- Off—Link is down or disabled.

40-Gigabit Ethernet **LINK LED**, one bicolor per port:

- Green—Link is up.
- Yellow—Link is disabled.
- Off—Link is down.

Related Documentation

- [MX Series MPC Overview on page 11](#)
- [MPCs Supported by MX240, MX480, MX960, MX2010, and MX2020 Routers on page 12](#)
- [MPC5E on MX Series Routers Overview](#)
- [10-Gigabit Ethernet OTN Options Configuration Overview](#)

6x40GE + 24x10GE MPC5EQ

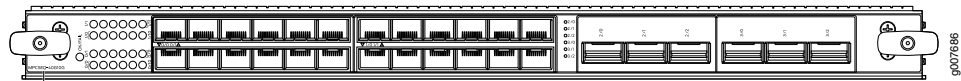

MPC5EQ-40G10G

Software release

- Junos OS Release 13.3R2 and later

Description

- Fixed-configuration MPC with six 40-Gigabit Ethernet ports and twenty-four 10-Gigabit Ethernet ports
- Weight: 21 lb (9.52 kg)
- Model number: MPC5EQ-40G10G
- Name in the CLI: **MPC5E 3D Q 24XGE+6XLGE**

- Hardware features**
- Line-rate throughput of up to 240 Gbps
 - Supports up to 1 million queues per-slot
 - LAN-PHY mode at 10.3125 Gbps on a per-port basis
 - WAN-PHY mode at 9.95328 Gbps on a per-port basis
 - The ports are labeled as:
 - 10-Gigabit Ethernet ports:
0/0 through 0/11
1/0 through 1/11
 - 40-Gigabit Ethernet ports:
2/0 through 2/2
3/0 through 3/2

NOTE: On MX960 routers, all the MPC slots work with the ambient temperature of up to 40° C. However, when the chassis temperature exceeds 40° C, slots 0 and 11 can work with MPC1s, MPC2s, and the 16x10GE MPC.

- Software features**
- Supports hierarchical QoS (HQoS)
 - Optical diagnostics and related alarms
 - Support for optical transport network (OTN) on 10-Gigabit Ethernet ports
 - Configurable LAN-PHY and WAN-PHY mode options per 10-Gigabit Ethernet port
 - Intelligent oversubscription services
 - See [“Protocols and Applications Supported by the MX240, MX480, MX960, MX2010, and MX2020 MPC5Es” on page 358](#) for information about the protocols and applications that this MPC supports.

NOTE: On MX240, MX480, and MX960 routers, MPC5E powers on only if the **network-services** mode on the router is configured to either **enhanced-ip** or **enhanced-ethernet**. On MX2010 and MX2020 routers, only **enhanced-ip** is supported.

- Cables and connectors**
- Fiber-optic 40-gigabit quad small form-factor pluggable plus (QSFP+)
 - 40GBASE-SR4 (model number: QSFP-40GBASE-SR4)
Connector: 12-fiber MPO
 - 40GBASE-LR4 (model number: QSFP-40GBASE-LR4)
Connector: Standard Duplex LC
 - 40GBASE-LX4 (model number: QSFP-40GE-LX4)
Connector: Standard Duplex LC

NOTE: QSFP-40GE-LX4 is not NEBS compliant on the MX960 router in FPC slot 0 or FPC slot 11.

Optical interface specifications—see [“40-Gigabit Ethernet 40GBASE-R Optical Interface Specifications” on page 64](#).

- Fiber-optic 10-gigabit small form-factor pluggable (SFP+) transceivers:
 - Connector: Duplex LC
 - 10GBASE-SR (model number: SFPP-10GE-SR)
 - 10GBASE-LR (model number: SFPP-10GE-LR)
 - 10GBASE-ER (model number: SFPP-10GE-ER-XT)
 - 10GBASE-Z (model number: SFPP-10G-ZR-OTN-XT)

Optical interface specifications—see [“10-Gigabit Ethernet 10GBASE Optical Interface Specifications” on page 54](#).

Power requirements	<ul style="list-style-type: none"> • Typical: 9.68 A @ 48 V (460 W) • At different temperatures: <ul style="list-style-type: none"> 55° C: 607 W 40° C: 541 W 25° C: 511 W
LEDs	<p>OK/FAIL LED, one bicolor:</p> <ul style="list-style-type: none"> • Steady green—MPC is functioning normally. • Blinking green—MPC is transitioning online or offline. • Red—MPC has failed. <p>10-Gigabit Ethernet LINK LED, one green per port:</p> <ul style="list-style-type: none"> • Green—Link is up. • Off—Link is down or disabled. <p>40-Gigabit Ethernet LINK LED, one bicolor per port:</p> <ul style="list-style-type: none"> • Green—Link is up. • Yellow—Link is disabled. • Off—Link is down.

Related Documentation

- [MX Series MPC Overview on page 11](#)
- [MPCs Supported by MX240, MX480, MX960, MX2010, and MX2020 Routers on page 12](#)
- [MPC5E on MX Series Routers Overview](#)
- [10-Gigabit Ethernet OTN Options Configuration Overview](#)

2x100GE + 4x10GE MPC5E

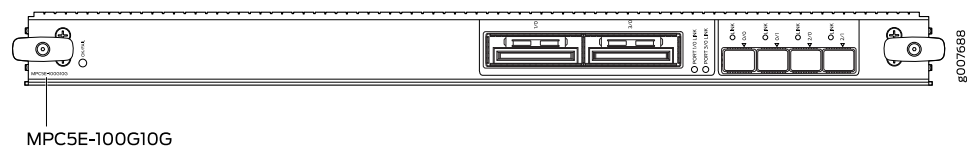

Software release

- Junos OS Release 13.3R3 and later

Description

- Fixed-configuration MPC with two 100-Gigabit Ethernet ports and four 10-Gigabit Ethernet ports
- Weight: 21 lb (9.52 kg)
- Model number: MPC5E-100G10G
- Name in the CLI: **MPC5E 3D 2CGE+4XGE**

- Hardware features**
- Line-rate throughput of up to 240 Gbps
 - Supports up to 32,000 queues per-slot
 - LAN-PHY mode at 10.3125 Gbps on a per-port basis
 - WAN-PHY mode at 9.95328 Gbps on a per-port basis
 - The ports are labeled as:
 - 10-Gigabit Ethernet ports: **0/0**, **0/1**, **2/0**, and **2/1**
 - 100-Gigabit Ethernet ports: **1/0** and **3/0**

NOTE: On MX960 routers, all the MPC slots work with the ambient temperature of up to 40° C. However, when the chassis temperature exceeds 40° C, slots **0** and **11** can work with MPC1s, MPC2s, and the 16x10GE MPC.

- Software features**
- Configurable LAN-PHY and WAN-PHY mode options per 10-Gigabit Ethernet port
 - Optical diagnostics and related alarms
 - Intelligent oversubscription services
 - See “[Protocols and Applications Supported by the MX240, MX480, MX960, MX2010, and MX2020 MPC5Es](#)” on page 358 for information about the protocols and applications that this MPC supports.

NOTE: On MX240, MX480, and MX960 routers, MPC5E powers on only if the **network-services** mode on the router is configured to either **enhanced-ip** or **enhanced-ethernet**. On MX2010 and MX2020 routers, only **enhanced-ip** is supported.

- Cables and connectors**
- Fiber-optic 10-gigabit small form-factor pluggable (SFP+) transceivers:
 - Connector: Duplex LC
 - 10GBASE-SR (model number: SFPP-10GE-SR)
 - 10GBASE-LR (model number: SFPP-10GE-LR)
 - 10GBASE-LR (model number: SFPP-10GE-LR-OTN)
 - 10GBASE-ER (model number: SFPP-10GE-ER-XT)
 - 10GBASE-Z (model number: SFPP-10G-ZR-OTN-XT)

Optical interface specifications—see “[10-Gigabit Ethernet 10GBASE Optical Interface Specifications](#)” on page 54.
 - 100-Gigabit Ethernet CFP2 transceivers:
 - Connector: Duplex LC
 - 100GBASE-LR4 (model number: CFP2-100GBASE-LR4)
 - 100GBASE-ER4 (model number: CFP2-100GBASE-ER4)
 - 100GBASE-ER4 (model number: CFP2-100G-ER4-D)

NOTE: CFP2-100G-ER4-D is not NEBS compliant on the MX960 router in FPC slot 0 or FPC slot 11.

 - Connector: 24-fiber MPO
 - 100GBASE-SR10 (model number: CFP2-100G-SR10-D3); also see “[Cable Specifications for MX Series Transceivers](#)” on page 43

Optical interface specifications—see “[100-Gigabit Ethernet 100GBASE-R Optical Interface Specifications](#)” on page 68.

- Power requirements**
- Typical: 10.52 A @ 48 V (505 W)
 - At different temperatures:
 - 55° C: 607 W
 - 40° C: 541 W
 - 25° C: 511 W

LEDs

OK/FAIL LED, one bicolor:

- Steady green—MPC is functioning normally.
- Blinking green—MPC is transitioning online or offline.
- Red—MPC has failed.

10-Gigabit Ethernet LINK LED, one bicolor per port:

- Green—Link is up.
- Yellow—Link is disabled.
- Off—Link is down or disabled.

100-Gigabit Ethernet LINK LED, one bicolor per port:

- Green—Link is up.
- Yellow—Link is disabled.
- Off—Link is down.

Related Documentation

- [MX Series MPC Overview on page 11](#)
- [MPCs Supported by MX240, MX480, MX960, MX2010, and MX2020 Routers on page 12](#)
- [MPC5E on MX Series Routers Overview](#)
- [10-Gigabit Ethernet OTN Options Configuration Overview](#)
- [100-Gigabit Ethernet OTN Options Configuration Overview](#)

2x100GE + 4x10GE MPC5EQ

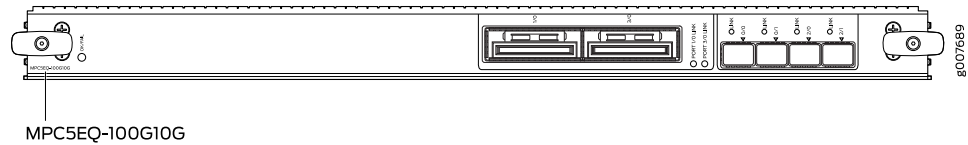

Software release • Junos OS Release 13.3R3 and later

Description • Fixed-configuration MPC with two 100-Gigabit Ethernet ports and four 10-Gigabit Ethernet ports
 • Weight: 21 lb (9.52 kg)
 • Model number: MPC5EQ-100G10G
 • Name in the CLI: **MPC5E 3D Q 2CGE+4XGE**

Hardware features • Line rate throughput of up to 240 Gbps
 • Supports up to 1 million queues per-slot
 • LAN-PHY mode at 10.3125 Gbps on a per-port basis
 • WAN-PHY mode at 9.95328 Gbps on a per-port basis
 • The ports are labeled as:
 • 10-Gigabit Ethernet ports: **0/0**, **0/1**, **2/0**, and **2/1**
 • 100-Gigabit Ethernet ports: **1/0** and **3/0**

NOTE: On MX960 routers, all the MPC slots work with the ambient temperature of up to 40° C. However, when the chassis temperature exceeds 40° C, slots 0 and 11 can work with MPC1s, MPC2s, and the 16x10GE MPC.

Software features

- Supports hierarchical QoS (HQoS)
- Configurable LAN-PHY and WAN-PHY mode options per 10-Gigabit Ethernet port
- Optical diagnostics and related alarms
- Intelligent oversubscription services
- See [“Protocols and Applications Supported by the MX240, MX480, MX960, MX2010, and MX2020 MPC5Es” on page 358](#) for information about the protocols and applications that this MPC supports.

NOTE: On MX240, MX480, and MX960 routers, MPC5E powers on only if the **network-services** mode on the router is configured to either **enhanced-ip** or **enhanced-ethernet**. On MX2010 and MX2020 routers, only **enhanced-ip** is supported.

Cables and connectors

- Fiber-optic 10-gigabit small form-factor pluggable (SFP+) transceivers:
 - Connector: Duplex LC
 - 10GBASE-SR (model number: SFPP-10GE-SR)
 - 10GBASE-LR (model number: SFPP-10GE-LR)
 - 10GBASE-LR (model number: SFPP-10GE-LR-OTN)
 - 10GBASE-ER (model number: SFPP-10GE-ER-XT)
 - 10GBASE-Z (model number: SFPP-10G-ZR-OTN-XT)Optical interface specifications—see [“10-Gigabit Ethernet 10GBASE Optical Interface Specifications” on page 54](#).
- 100-Gigabit Ethernet CFP2 transceivers:
 - Connector: Duplex LC
 - 100GBASE-LR4 (model number: CFP2-100GBASE-LR4)
 - 100GBASE-ER4 (model number: CFP2-100GBASE-ER4)
 - 100GBASE-ER4 (model number: CFP2-100G-ER4-D)

NOTE: CFP2-100G-ER4-D is not NEBS compliant on the MX960 router in FPC slot 0 or FPC slot 11.

 - Connector: 24-fiber MPO
 - 100GBASE-SR10 (model numbers: CFP2-100GBASE-SR10 for LAN rates and CFP2-100G-SR10-D3 for LAN/OTN rates; also see [“Cable Specifications for MX Series Transceivers” on page 43](#))Optical interface specifications—see [“100-Gigabit Ethernet 100GBASE-R Optical Interface Specifications” on page 68](#).

Power requirements

- Typical: 10.52 A @ 48 V (505 W)
- At different temperatures:
 - 55° C: 607 W
 - 40° C: 541 W
 - 25° C: 511 W

- LEDs
- OK/FAIL LED, one bicolor:**
- Steady green—MPC is functioning normally.
 - Blinking green—MPC is transitioning online or offline.
 - Red—MPC has failed.
- 10-Gigabit Ethernet LINK LED, one bicolor per port:**
- Green—Link is up.
 - Yellow—Link is disabled.
 - Off—Link is down or disabled.
- 100-Gigabit Ethernet LINK LED, one bicolor per port:**
- Green—Link is up.
 - Yellow—Link is disabled.
 - Off—Link is down.

- Related Documentation**
- [MX Series MPC Overview on page 11](#)
 - [MPCs Supported by MX240, MX480, MX960, MX2010, and MX2020 Routers on page 12](#)
 - [MPC5E on MX Series Routers Overview](#)
 - [10-Gigabit Ethernet OTN Options Configuration Overview](#)
 - [100-Gigabit Ethernet OTN Options Configuration Overview](#)

MPC6E

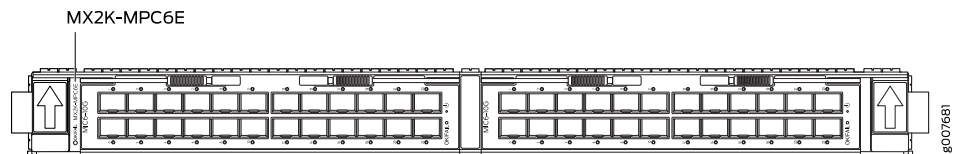

Software release	<ul style="list-style-type: none"> • Junos OS Release 13.3R2 and later <p>For information about which MICs are supported on this MPC, “MIC/MPC Compatibility” on page 21.</p>
Description	<ul style="list-style-type: none"> • Two slots for MICs • Power requirement: 20.9 A @ 52 V (880 W; plus 104 W for each MIC) • Weight: 27.4 lb (12.43 kg) (net weight without blank panels) • Model number: MX2K-MPC6E • Name in the CLI: MPC6E 3D
Hardware features	<ul style="list-style-type: none"> • Two slots for MICs • Line-rate throughput of up to 480 Gbps • Field-removable septum, to accommodate future full-height MICs

Software features

- Optical diagnostics and related alarms
- Configurable LAN-PHY and WAN-PHY mode options per 10-Gigabit Ethernet port
- Two Packet Forwarding Engines for each MIC slot
- Intelligent oversubscription services
- See “[Protocols and Applications Supported by the MX2010 and MX2020 MPC6E](#)” on page 365 for information about the protocols and applications that this MPC supports.

LEDs

OK/FAIL LED, one bicolor:

- Steady green—MPC is functioning normally.
- Blinking green—MPC is transitioning online or offline.
- Red—MPC has failed.

LINK LED, one bicolor per port:

- Green—Link is up.
- Yellow—Link is disabled.
- Off—Link is down.

Related Documentation

- [MX Series MPC Overview on page 11](#)
- [MPCs Supported by MX240, MX480, MX960, MX2010, and MX2020 Routers on page 12](#)
- [MPC6E on MX Series Routers Overview](#)

MPC7E (Multi-Rate)

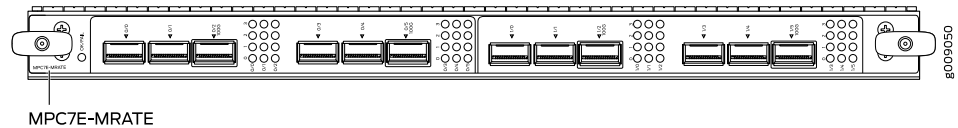

Software release

- Junos OS Release 15.1F4 with Junos Continuity.
- Junos OS release 16.1R1 and later.

Description

- Fixed-configuration MPC with 10-Gbps, 40-Gbps, and 100-Gbps port speeds
- Weight: 15.7 lb (7.12 kg)
- Model number: MPC7E-MRATE
- Name in the CLI: **MPC7E-MRATE**

Hardware features

- Line-rate throughput of up to 480 Gbps on MX240, MX480, and MX960 routers.
- Line-rate throughput of up to 400 Gbps on MX2000 routers with SFB, and up to 430 Gbps on MX2000 routers with SFB2.
- Junos Trio chipsets for increased scaling for bandwidth, subscribers, and services
- Twelve Gigabit Ethernet ports that can be configured as 40-Gigabit Ethernet port or as 4 10-Gigabit Ethernet port using a breakout cable. The ports support quad small-form factor pluggable plus (QSFP+) transceivers.
- Four out of the twelve ports can be configured as 100-Gigabit Ethernet ports. Port numbers **0/2**, **0/5**, **1/2** and **1/5** are the four 100-Gigabit Ethernet ports.
- You can configure different combination of port speeds as long as the aggregate capacity per group of six ports labeled **0/0** through **0/5** does not exceed 240 Gbps. Similarly, aggregate capacity per group of the other six ports labeled **1/0** through **1/5** should not exceed 240 Gbps.
- Requires high-capacity power supplies, high-capacity fan trays, and SCBE2 on MX240, MX480, and MX960 routers.
- Requires an adapter card to be housed in MX2000 routers.
- The ports are labeled as (with the MPC orientation as shown in the above figure):
 - 10-Gigabit Ethernet or 40-Gigabit Ethernet ports:
0/0, **0/1**, **0/2 100G**, **0/3**, **0/4**, **0/5 100G**, **1/0**, **1/1**, **1/2 100G**, **1/3**, **1/4**, and **1/5 100G**
 - 100-Gigabit Ethernet ports:
0/2 100G, **0/5 100G**, **1/2 100G** and **1/5 100G**

NOTE: Only ports marked **100G** support 100-Gigabit Ethernet speed using QSFP28 transceivers.

- Supports maximum transmission units (MTUs) from 256 bytes through 16,000 bytes.

NOTE: On MX960 routers, all the MPC slots can be occupied by MPC7E (Multi-Rate) at an ambient temperature of up to 40° C and at any altitude. All the MPC slots can be occupied by MPC7E (Multi-Rate) at temperatures of up to 55° C and at sea level. At an ambient temperature of 55° C and above, and at an altitude above sea level, slot **11** cannot host MPC7E (Multi-Rate).

Software features

- Supports rate selectability at the port level.
- By default, the ports are configured as 10-Gigabit Ethernet ports.
- Optical diagnostics and related alarms
- See “[Protocols and Applications Supported by the MX240, MX480, MX960, MX2010, and MX2020 MPC7Es](#)” on page 372 for information about the protocols and applications that the MPC7E supports.

NOTE: On MX240, MX480, and MX960 routers, MPC7E powers on only if the **network-services** mode on the router is configured as either **enhanced-ip** or **enhanced-ethernet**. On MX2000 router no additional configuration is required as by default the router operates in **enhanced-ip** mode.

- Cables and connectors**
- Fiber-optic 10-gigabit QSFP+ transceiver
 - 4x duplex LC breakout cable—To interface with an SFP+ transceiver at the other end. A breakout cable consists of a QSFP+ transceiver on one end (that connects to the router) and four SFP+ transceivers on the other end.
 - 10GBASE-L (model number: QSFPP-4X10GE-LR)
Connector: Female receptacle, MPO
 - 10GBASE-S (model number: QSFPP-4X10GE-SR)
Connector: Female receptacle, MPO
 - Optical interface specifications—see [“10-Gigabit Ethernet 10GBASE Optical Interface Specifications”](#) on page 54.
 - Fiber-optic 40-gigabit QSFP+ transceiver
 - 40GBASE-SR4 (model number: QSFPP-40GBASE-SR4)
Connector: Female receptacle, MPO
 - 40GBASE-LR4 (model number: QSFPP-40GBASE-LR4)
Connector: Standard Duplex LC
 - Optical interface specifications—see [“40-Gigabit Ethernet 40GBASE-R Optical Interface Specifications”](#) on page 64.
 - Fiber-optic 100-gigabit QSFP+ transceiver
 - 100GBASE-SR4 (model number: QSFP-100GBASE-SR4)
Connector: MPO
 - 100GBASE-LR4 (model number: QSFP-100GBASE-LR4)
Connector: Standard Duplex LC
 - Optical interface specifications—see [“100-Gigabit Ethernet 100GBASE-R Optical Interface Specifications”](#) on page 68.

- Power requirements**
- At different temperatures:
 - 55° C: 545 W
 - 40° C: 465 W
 - 25° C: 440 W

- LEDs**
- OK/FAIL LED**, one bicolor:
- Steady green—MPC is functioning normally.
 - Yellow—MPC has failed.
- LINK LED**, one green per port (4 per QSFP+ cage):
- Steady green—Link is up.
 - Off—Link is down or disabled.

- Related Documentation**
- [MPC7E \(Multi-Rate\) on MX Series Routers Overview](#)
 - [MX Series MPC Overview on page 11](#)
 - [MPCs Supported by MX240, MX480, MX960, MX2010, and MX2020 Routers on page 12](#)
 - [Junos Continuity Software \(Junos OS Release 14.1R4 and Later Releases\)](#)

MPC7E 10G

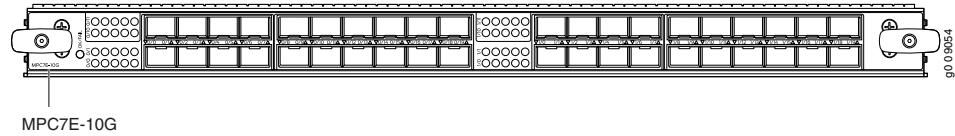

Software release	<ul style="list-style-type: none"> Junos OS Release 15.1F5 with Junos Continuity Junos OS release 16.1R1 and later
Description	<ul style="list-style-type: none"> Fixed-configuration MPC with forty 10-Gbps ports Weight: 17 lb (7.7 kg) Model number: MPC7E-10G Name in the CLI: MPC7E 3D 40XGE
Hardware features	<ul style="list-style-type: none"> Line-rate throughput of up to 400 Gbps on MX240, MX480, and MX960 routers. Line-rate throughput of up to 400 Gbps on MX2000 routers. Junos Trio chipsets for increased scaling for bandwidth, subscribers, and services. Forty 10-Gigabit Ethernet ports. The ports support SFP+ transceivers. Requires high-capacity power supplies, high-capacity fan trays, and SCBE2 on MX240, MX480, and MX960 routers. Requires an adapter card to be housed in MX2000 routers. Support maximum transmission units (MTUs) from 256 bytes through 16,000 bytes. The ports are labeled as (with the MPC orientation as shown in the figure): <ul style="list-style-type: none"> 0/0 through 0/9 0/10 through 0/19 1/0 through 1/9 1/10 through 1/19
Software features	<ul style="list-style-type: none"> Supports Hyper mode to speed up packet processing. Supports Flexible queuing using an add-on license to support 32,000 queues per line card, including queues on both ingress and egress interfaces. You can use an additional license to support up to 512,000 queues. Optical diagnostics and related alarms See “Protocols and Applications Supported by the MX240, MX480, MX960, MX2010, and MX2020 MPC7Es” on page 372 for information about the protocols and applications that MPC7Es support. <p>NOTE: On MX240, MX480, and MX960 routers, MPC7E powers on only if the network-services mode on the router is configured as either enhanced-ip or enhanced-ethernet. On MX2000 routers, no additional configuration is required because by default the router operates in enhanced-ip mode.</p>

- Cables and connectors**
- Fiber-optic 10-gigabit SFP+ transceivers:
 - Connector: Duplex LC
 - 10GBASE-SR (model number: SFPP-10GE-SR)
 - 10GBASE-LR (model number: SFPP-10GE-LR)
 - 10GBASE-ER (model number: SFPP-10GE-ER)
 - 10GBASE-ER (model number: SFPP-10GE-ER-XT)
 - 10GBASE-ZR (model number: SFPP-10G-ZR-OTN-XT)

NOTE: MPC7E 10G does not support OTN rates.

Optical interface specifications—see “10-Gigabit Ethernet 10GBASE Optical Interface Specifications” on page 54.

- Power requirements**
- Typical: 405 W
 - At different temperatures:
 - 55° C: 500 W
 - 40° C: 465 W
 - 25° C: 430 W

NOTE: On MX960 routers, all the MPC slots can be occupied by MPC7E 10G at an ambient temperature of up to 40° C and at any altitude. All the MPC slots can be occupied by MPC7E 10G at temperatures of up to 55° C and at sea level. At an ambient temperature of 55° C and above, and at an altitude above sea level, slot 11 cannot host MPC7E 10G.

- LEDs**
- OK/FAIL LED, one bicolor:**
- Steady green—MPC is functioning normally.
 - Yellow—MPC has failed.
- Link LED, one green per port:**
- Steady green—Link is up.
 - Off—Link is down or disabled.

- Related Documentation**
- [MPC7E 10G on MX Series Routers Overview](#)
 - [MX Series MPC Overview on page 11](#)
 - [MPCs Supported by MX240, MX480, MX960, MX2010, and MX2020 Routers on page 12](#)
 - [Junos Continuity Software \(Junos OS Release 14.1R4 and Later Releases\)](#)

MPC8E

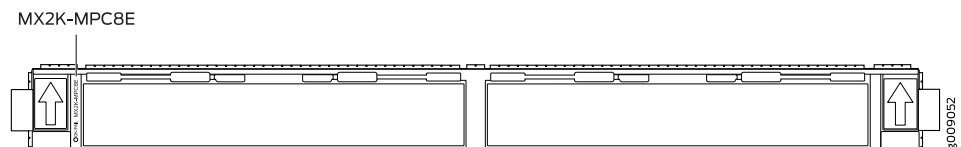

- Software release**
- Junos OS Release 15.1F5 with Junos Continuity
 - Junos OS release 16.1R1 and later

Description	<ul style="list-style-type: none"> Weight: 31.4 lb (14.24 kg) (net weight without blank panels) Model number: MX2K-MPC8E Name in the CLI: MPC8E 3D
Hardware features	<ul style="list-style-type: none"> Line-rate throughput of up to 960 Gbps on the MX2000 routers. Line-rate throughput of up to 1600 Gbps (1.6 Tbps) on the MX2000 routers with software upgrade. <ul style="list-style-type: none"> NOTE: Starting from Junos OS Release 16.1R1, you can upgrade MPC8E to provide an increased bandwidth of 1600 Gbps (1.6 Tbps) by using an add-on license. After you perform the upgrade, MPC8E provides a bandwidth of 1.6 Tbps, which is equivalent to the bandwidth of "MPC9E" on page 188. However, the MPC continues to be identified as MPC8E. Four Packet Forwarding Engines, each providing a maximum bandwidth of 240 Gbps in normal mode and 400 Gbps in 1.6Tbps upgraded mode. A license is required to operate in 1.6 Tbps upgraded mode. Supports two MICs. For information about which MICs are supported on this MPC, see "MIC/MPC Compatibility" on page 21. Junos Trio chipsets for increased scaling for bandwidth, subscribers, and services. Supports the Switch Fabric Boards SFB and SFB2. When MPC8E is used with SFB, the line-rate throughput is limited to 800 Gbps. Support maximum transmission units (MTUs) from 256 bytes through 16,000 bytes.
Software features	<ul style="list-style-type: none"> Dynamic power management for effective utilization of available power. Inline flow monitoring for higher scalability and performance. Flexible queuing using an add-on license to support 32,000 queues per line card, including queues on both ingress and egress interfaces. You can use an additional license to support up to 512,000 queues per slot or 1,000,000 queues per slot. Hyper mode to speed up packet processing. Optical diagnostics and related alarms. <p>For more information about features supported on MPC8E, see "Protocols and Applications Supported by MPC8E and MPC9E on the MX2010 and MX2020 Routers" on page 381.</p>
Power requirements (without MICs)	<p>Normal mode with line-rate throughput of 960 Gbps:</p> <ul style="list-style-type: none"> Typical: 688 W At different temperatures: <ul style="list-style-type: none"> 55° C: 805 W 40° C: 720 W 25° C: 690 W <p>Upgrade mode with line-rate throughput of 1.6 Tbps:</p> <ul style="list-style-type: none"> Typical: 838 W At different temperatures: <ul style="list-style-type: none"> 55° C: 1018 W 40° C: 870 W 25° C: 840 W
LEDs	<p>OK/FAIL LED, one bicolor:</p> <ul style="list-style-type: none"> Steady green—MPC is functioning normally. Yellow—MPC has failed.

- Related Documentation**
- [MPC8E on MX Series Routers Overview](#)
 - [MX Series MPC Overview on page 11](#)

- [MPCs Supported by MX240, MX480, MX960, MX2010, and MX2020 Routers on page 12](#)
- [Junos Continuity Software \(Junos OS Release 14.1R4 and Later Releases\)](#)
- [Understanding Rate Selectability](#)

MPC9E

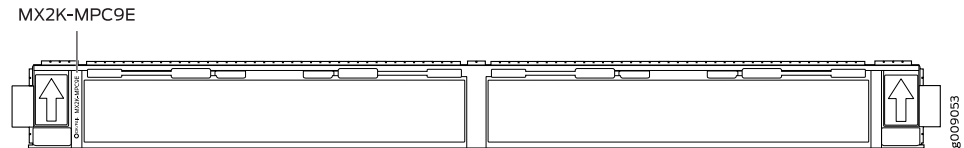

Software release	<ul style="list-style-type: none"> • Junos OS Release 15.1F5 with Junos Continuity • Junos OS release 16.1R1 and later
Description	<ul style="list-style-type: none"> • Weight: 31.4 lb (14.24 kg) (net weight without blank panels) • Model number: MX2K-MPC9E • Name in the CLI: MPC9E 3D
Hardware features	<ul style="list-style-type: none"> • Line-rate throughput of up to 1600 Gbps (1.6 Tbps) on MX2000 routers. • Four Packet Forwarding Engines, each providing a maximum bandwidth of 400 Gbps. • Supports two MICs. For information about which MICs are supported on this MPC, see “MIC/MPC Compatibility” on page 21. • Junos Trio chipsets for increased scaling for bandwidth, subscribers, and services • Supports the Switch Fabric Boards SFB and SFB2. When MPC9E is used with SFB, the line-rate throughput is limited to 800 Gbps. • Support maximum transmission units (MTUs) from 256 bytes through 16,000 bytes.
Software features	<ul style="list-style-type: none"> • Dynamic power management for effective utilization of available power. • Inline flow monitoring for higher scalability and performance. • Flexible queuing using an add-on license to support 32,000 queues per line card, including queues on both ingress and egress interfaces. You can use an additional license to support up to 512,000 queues per slot or 1,000,000 queues per slot. • Hyper mode to speed up packet processing. • Optical diagnostics and related alarms. <p>For more information about features supported on MPC9E, see “Protocols and Applications Supported by the MX240, MX480, MX960, MX2010, and MX2020 MPC7Es” on page 372.</p>
Power requirements (without MICs)	<ul style="list-style-type: none"> • Typical: 838 W • At different temperatures: <ul style="list-style-type: none"> 55° C: 1018 W 40° C: 870 W 25° C: 840 W
LEDs	<p>OK/FAIL LED, one bicolor:</p> <ul style="list-style-type: none"> • Steady green—MPC is functioning normally. • Yellow—MPC has failed.

**Related
Documentation**

- *MPC9E on MX Series Routers Overview*
- [MX Series MPC Overview on page 11](#)
- [MPCs Supported by MX240, MX480, MX960, MX2010, and MX2020 Routers on page 12](#)
- *Junos Continuity Software (Junos OS Release 14.1R4 and Later Releases)*
- *Understanding Rate Selectability*

CHAPTER 9

MX Series MIC Descriptions

- ATM MIC with SFP on page 192
- DS3/E3 MIC on page 196
- Gigabit Ethernet MIC with SFP on page 199
- Gigabit Ethernet MIC with SFP (E) on page 203
- Gigabit Ethernet MIC with SFP (EH) on page 207
- 10-Gigabit Ethernet MICs with XFP on page 209
- 10-Gigabit Ethernet MIC with SFP+ (10 Ports) on page 211
- 10-Gigabit Ethernet MIC with SFP+ (24 Ports) on page 213
- 10-Gigabit Ethernet OTN MIC with SFP+ (24 Ports) on page 214
- 40-Gigabit Ethernet MIC with QSFP+ on page 216
- 100-Gigabit Ethernet MIC with CFP on page 217
- 100-Gigabit Ethernet MIC with CXP on page 219
- 100-Gigabit Ethernet MIC with CXP (4 Ports) on page 220
- 100-Gigabit Ethernet MIC with CFP2 on page 221
- 100-Gigabit DWDM OTN MIC with CFP2-ACO on page 223
- Channelized SONET/SDH OC3/STM1 (Multi-Rate) MICs with SFP on page 232
- Channelized OC3/STM1 (Multi-Rate) Circuit Emulation MIC with SFP on page 236
- Channelized OC3/STM1 (Multi-Rate) Circuit Emulation MIC with SFP (H) on page 239
- Channelized E1/T1 Circuit Emulation MIC on page 241
- Channelized E1/T1 Circuit Emulation MIC (H) on page 244
- Tri-Rate MIC on page 247
- MIC MRATE on page 251
- Multiservices MIC on page 253
- SONET/SDH OC3/STM1 (Multi-Rate) MICs with SFP on page 254
- SONET/SDH OC192/STM64 MIC with XFP on page 258

ATM MIC with SFP

Figure 7: 8-Port ATM MIC with SFP

MIC-3D-OCx-ATM

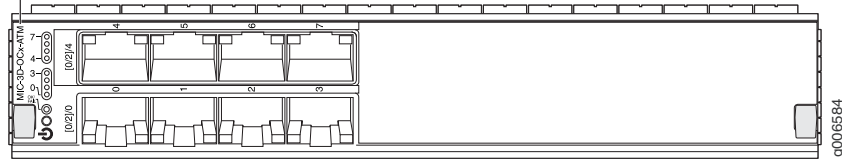

Software release

- Junos 12.1 and later

For information on which MPCs support this MIC, see [“MIC/MPC Compatibility” on page 21](#). For information on which MICs are supported on MX Series routers, see [“MICs Supported by MX Series Routers” on page 17](#).

Description

- Rate-selectable using one of the following rates:
 - 8-port OC3
 - 2-port OC12
- Power requirement: 0.73 A @ 48 V (35 W)
- Weight: 1.2 lb (0.54 kg)
- Model number: MIC-3D-8OC3-2OC12-ATM
- Name in the CLI: **3D 8OC3 2OC12 ATM**

Hardware features

- High-performance parsing of SONET/SDH frames
- Packet segmentation and reassembly (SAR) management and output port queuing
- Packet buffering, Layer 2 parsing
- Line rate throughput for each port

Software features

- Circuit cross-connect (CCC) for leveraging ATM access networks
- User-configurable virtual circuit (VC) and virtual path (VP) support
- Support for idle cell or unassigned cell transmission
- OAM fault management processes alarm indication signal (AIS), remote defect indication (RDI) cells, and loop cells
- Point-to-point and point-to-multipoint mode Layer 2 counters per VC and per VP
- Local and remote loopback
- Simple Network Management Protocol (SNMP):
 - Management Information Base (MIB) 2 (RFC 1213)
 - ATM MIB (RFC 1695)
 - SONET MIB
 - PWE3 MIB (RFC 5603)
 - PW-ATM-MIB (RFC 5605)
 - PW-FRAME-MIB (RFC 5601)
 - MIB for CoS
- Unspecified bit rate (UBR), non-real-time variable bit rate (VBR), and constant bit rate (CBR) traffic shaping
- Per-VC or per-VP traffic shaping
- Support for F4 OAM cells (AIS, RDI, Loopback, and Continuity Check)
- Support for F5 OAM cells (AIS, RDI, Loopback, and Continuity Check)
- Support for 16 bit VCI range
- Encapsulations:
 - atm-ccc-cell-relay (Junos 12.1 and later)
 - atm-ccc-vc-mux (Junos 12.1 and later)
 - atm-snap (Junos 12.2 and later)
 - atm-vc-mux (Junos 12.2 and later)
 - atm-tcc-snap (Junos 13.3 and later)
 - atm-tcc-vc-mux (Junos 13.3 and later)
 - vlan-vci-ccc (Junos 16.1 and later)
 - ether-over-atm-llc
 - ppp-over-ether-over-atm-llc
 - atm-ppp-llc
 - atm-ppp-vc-mux

NOTE: Inline MLPPP is not supported on this MIC.

- Cables and connectors
- Duplex LC/PC connector (Rx and Tx)
 - SONET/SDH OC3/STM1 small form-factor pluggable (SFP) transceivers:
 - Multimode (model number: SFP-OC3-SR)
 - Intermediate reach (IR-1) (model number: SFP-OC3-IR)
 - Long reach (LR-1) (model number: SFP-OC3-LR)Optical interface specifications—see [“SONET/SDH OC3/STM1 Optical Interface Specifications” on page 76](#)
 - SONET/SDH OC12/STM4 small form-factor pluggable (SFP) transceivers:
 - Short reach (model number: SFP-OC12-SR)
 - Intermediate reach (IR-1) (model number: SFP-OC12-IR)
 - Long reach (LR-1) (model number: SFP-OC12-LR)Optical interface specifications—see [“SONET/SDH OC12/STM4 Optical Interface Specifications” on page 78](#)

LEDs**OK/FAIL LED, one bicolor:**

- Green—MIC is functioning normally.
- Red—MIC has failed.

Link LED, one green per port:

- Off—No link.
- On steadily—Link is up.
- Blinking—Online with alarms for remote failures
- Blinking rapidly—Active with a local alarm; router has detected a failure

Alarms, errors, and events

- Alarm indication signal—line (AIS-L)
- Alarm indication signal—path (AIS-P)
- Bit error rate—signal degrade (BERR-SD)
- Bit error rate—signal fail (BERR-SF)
- Loss of cell delineation (LOC)
- Loss of frame (LOF)
- Loss of pointer (LOP-P)
- Loss of signal (LOS)
- Payload mismatch (PLM-P)
- Payload unequipped (unequipped STS at path level) (UNEQ-P)
- Remote defect indication—line (RDI-L)
- Remote defect indication—path (RDI-P)
- Error detection:
 - Bit interleaved parity errors B1, B2, B3
 - Errored seconds (ES-S, ES-L, ES-P)
 - Far-end bit errors, remote error indication—line (REI-L), far-end line coding violations (CV-LFE)
 - Far-end bit errors, remote error indication—path (REI-P), far-end path coding violations (CV-PFE)
 - Far-end errored seconds (ES-LFE, ES-PFE)
 - Far-end severely errored seconds (SES-LFE, SES-PFE)
 - Far-end unavailable seconds (UAS-LFE, UAS-PFE)
 - Severely errored framing (SEF)
 - Severely errored framing seconds (SEFS-S)
 - Severely errored seconds (SES-S, SES-L, SES-P)
 - Unavailable seconds (UAS-L, UAS-P)



NOTE: MIC-3D-8OC3-2OC12-ATM Revision 8 and Revision 22 are supported only by the following Junos OS releases:

- Junos OS Release 12.3—12.3R9 and later
- Junos OS Release 13.3—13.3R6 and later
- Junos OS Release 14.1—14.1R4 and later
- Junos OS Release 14.2—14.2R3 and later
- Junos OS Release 15.1 and later

You must upgrade to a supported Junos OS release to use MIC-3D-8OC3-2OC12-ATM Revision 8 and Revision 22 and later.

Related Documentation

- [MX Series MIC Overview on page 17](#)

DS3/E3 MIC

Figure 8: DS3/E3 MIC

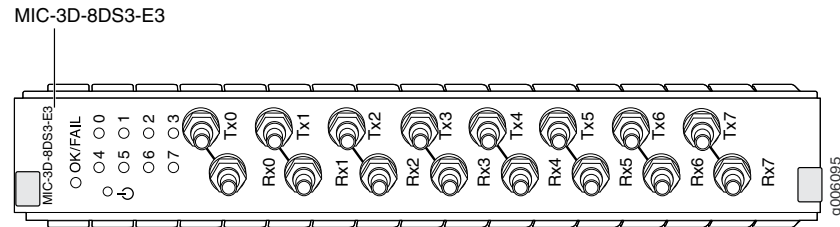

Software release

- Junos OS Release 11.4 and later

For information on which MPCs support this MIC, see [“MIC/MPC Compatibility” on page 21](#). For information on which MICs are supported on MX Series routers, see [“MICs Supported by MX Series Routers” on page 17](#).

Description

- Eight E3 or DS3 ports
- DS3/E3 MIC ports can be configured as one of the following:
 - 8 clear-channel DS3 ports
 - 8 channelized DS3 ports
 - 8 clear-channel E3 ports

NOTE: You can upgrade the DS3/E3 MIC with the S-MIC-3D-8CHDS3 software license (purchased separately) to support DS3 channelization. Channelized DS3/E3 MIC is supported only on queuing MPCs. On the MX80 router, you also need an S-MX80-Q software license.

- DS3 or E3 is configurable on a per-port granularity
- DS3 channelization for the 8-port Channelized DS3/E3 MIC:
 - 8 DS3 channels
 - 224 DS1 channels
 - 2038 DS0 channels
- Power requirement: 4.0 A @ 9 V (36W)
- Weight: 4.4 lb (2 kg)
- Model numbers:
 - DS3/E3 MIC: MIC-3D-8DS3-E3
 - Channelized DS3/E3 MIC: MIC-3D-8CHDS3-E3-B

Hardware features

- Ports are numbered 0 through 7, Tx0 through Tx7 and Rx0 through Rx7

Software features

- Maximum transmission units (MTUs) of up to 9192 bytes
- Framing: M13, C-bit parity, framed clear channel
- Subrate and scrambling:

NOTE: Only DS3 interfaces support subrate and scrambling.

- Digital Link/Quick Eagle
- Kentrox
- Larscom
- ADTRAN
- Verilink
- Internal and look clocking
- DS3 far-end alarm and control (FEAC) channel
- Full bit error rate test (BERT) for DS0, DS1, and DS3
- Encapsulations:
 - MPLS fast reroute
 - MPLS CCC (circuit cross-connection)
 - MPLS TCC (translational cross-connection)
 - Cisco High-Level Data Link Control (cHDLC)
 - Cisco HDLC CCC
 - Cisco HDLC TCC
 - Point-to-Point Protocol (PPP)
 - PPP for CCC
 - PPP for TCC
 - Flexible Frame Relay
 - Frame Relay
 - Frame Relay for CCC
 - Frame Relay for TCC
 - PPP over Frame Relay

NOTE: Ethernet over Frame Relay is not supported.

- Encapsulations available only for Channelized DS3/E3 MIC (Junos OS Release 12.1 and later):
 - Multilink Point-to-Point Protocol (MLPPP)
 - Multiclass MLPPP
 - Multilink Frame Relay (MLFR) end-to-end (FRF.15)
 - Multilink Frame Relay (MLFR) UNI NNI (FRF.16, also referred to as MFR)
 - Compressed Real-Time Transport Protocol (CRTP)

NOTE: When you configure multilink services on a MIC in an MX Series router, ensure that a Multiservices DPC is present in the same router.

Cables and connectors

- Coaxial:
 - Custom 10-ft (3-m) mini-SMB to BNC cable (model number: CBL-DS3-E3-M-S), set of 8 cables (bundled RX and TX)

LEDs**OK/FAIL LED, one bicolor:**

- Green—MIC is functioning normally
- Red—MIC has failed

Link LED, one green per port:

- Off—Not enabled
- Green—Online with no alarms or failures
- Yellow—Online with alarms for remote failures
- Red—Active with a local alarm; router has detected a failure

Alarms, errors, and events**DS3 alarms:**

- Alarm indication signal (AIS)
- Loss of frame (LOF)
- Loss of signal seconds (LOS)
- Phase lock loop (PLL)

DS3 error detection:

- C-bit code violations (CCV)
- C-bit errored seconds (CES)
- C-bit severely errored seconds (CSES)
- CRC errors
- Excessive zeros (EXZ)
- Far-end block error (FEBE)
- Far-end receive failure (FERF)
- Line errored seconds (LES)
- Parity bit (P-bit) code violations (PCV)
- Parity bit (P-bit) errored seconds (PES)
- Parity bit (P-bit) severely errored framing seconds (PSES)
- Severely errored framing seconds (SEFS)
- Unavailable seconds (UAS)

Related Documentation

- [MX Series MIC Overview on page 17](#)

Gigabit Ethernet MIC with SFP

Figure 9: 20-Port Gigabit Ethernet MIC with SFP

MIC-3D-20GE-SFP

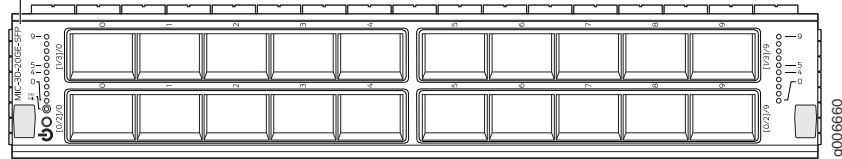

Software release	<ul style="list-style-type: none"> Junos 10.1 and later <p>For information on which MPCs support this MIC, see “MIC/MPC Compatibility” on page 21. For information on which MICs are supported on MX Series routers, see “MICs Supported by MX Series Routers” on page 17.</p>
Description	<ul style="list-style-type: none"> 20 Gigabit Ethernet ports Power requirement: 0.77 A @ 48 V (37 W) Weight: 1.2 lb (0.54 kg) Model number: MIC-3D-20GE-SFP Name in the CLI: 3D 20GE SFP
Hardware features	<ul style="list-style-type: none"> High-performance throughput on each port at speeds up to 1 Gbps Autonegotiation between Gigabit Ethernet circuit partners Up to 20-Gbps of full-duplex traffic Maximum transmission units (MTUs) of up to 9192 bytes
Software features	<ul style="list-style-type: none"> Optical diagnostics and related alarms Virtual Router Redundancy Protocol (VRRP) support IEEE 802.1Q virtual LANs (VLANs) support Remote monitoring (RMON) EtherStats Source MAC learning MAC accounting and policing—Dynamic local address learning of source MAC addresses Flexible Ethernet encapsulation Multiple tag protocol identifiers (TPID)
Interfaces	<p>Syntax: <i>ge-fpc/pic/port</i> where:</p> <ul style="list-style-type: none"> fpc: Slot in the router where the MPC is installed pic: The logical PIC number on the MIC, numbered 0, 1, 2, and 3. port: 0 through 9 <p>For example, <i>ge-3/3/0</i> is the interface for port 0 in PIC 3 on the MPC installed in slot 3.</p> <p>Figure 10 on page 201, Figure 11 on page 202, and Figure 12 on page 202 show examples of the port numbering for the Gigabit Ethernet MIC with SFP installed in an MX960, MX480, and MX240, respectively.</p>

Cables and connectors

- Fiber-optic small form-factor pluggable (SFP) transceivers:

- Connector: Duplex LC/PC (Rx and Tx)
- 100BASE-FX (model number: SFP-1FE-FX)
- 1000BASE-EX (model number: SFP-GE40KM)
- 1000BASE-LH (model number: SFP-1GE-LH)
- 1000BASE-LX (model number: SFP-1GE-LX)
- 1000BASE-SX (model number: SFP-1GE-SX)

Optical interface specifications—see [“Fast Ethernet 100BASE-FX Optical Interface Specifications” on page 48](#) and [“Gigabit Ethernet 1000BASE Optical Interface Specifications” on page 44](#)

- Copper SFP transceivers:

- Connector: Four-pair, Category 5 shielded twisted-pair connectivity through an RJ-45 connector
- 1000BASE-T (model number: SFP-1GE-T)
- 10/100/1000BASE-T (model number: SFP-1GE-FE-E-T)

NOTE: SFP-1GE-FE-E-T supports tri-rate 10/100/1000 mode in Junos OS Release 9.4 and later

- Pinout: MDI, MDI crossover
- Length: 328 ft/100 m

Copper interface specifications—see [“Ethernet 10BASE-T Copper Interface Specifications” on page 48](#), [“Fast Ethernet 100BASE-T Copper Interface Specifications” on page 49](#), and [“Gigabit Ethernet 1000BASE-T Copper Interface Specifications” on page 47](#)

- Bidirectional SFP transceivers:

- Connector: Duplex LC/PC (Rx and Tx)
- 100BASE-BX (model number pairs: SFP-FE20KT13R15 with SFP-FE20KT15R13)
- 1000BASE-BX (model number pairs: SFP-GE10KT13R14 with SFP-GE10KT14R13, SFP-GE10KT13R15 with SFP-GE10KT15R13, SFP-GE40KT13R15 with SFP-GE40KT15R13)

Optical interface specifications—see [“Fast Ethernet and Gigabit Ethernet Bidirectional SFP Optical Interface Specifications” on page 50](#)

- The following transceivers support operation and monitoring with links up to a distance of 80 km. Each transceiver is tuned to a different transmit wavelength for use in CWDM applications.

- Connector: Duplex LC (Rx and Tx)
- Supported in Junos OS Release 12.3R5, 13.2R3, 13.3R1, and later
- SFP-GE80KCW1470-ET
- SFP-GE80KCW1490-ET
- SFP-GE80KCW1510-ET
- SFP-GE80KCW1530-ET
- SFP-GE80KCW1550-ET
- SFP-GE80KCW1570-ET
- SFP-GE80KCW1590-ET
- SFP-GE80KCW1610-ET

Optical interface specifications—see [“Gigabit Ethernet SFP CWDM Optical Interface Specifications” on page 53](#)

LEDs

OK/FAIL LED, one bicolor:

- Green—MIC is functioning normally.
- Red—MIC has failed.

Link LED, one green per port:

- Off—No link.
- On steadily—Link is up.

Port Numbering

Figure 10 on page 201, Figure 11 on page 202, and Figure 12 on page 202 show examples of the port numbering for the Gigabit Ethernet MIC with SFP on the MX960, MX480, and MX240, respectively.

Figure 10: Port Numbering for the Gigabit Ethernet MIC with SFP (MX960)

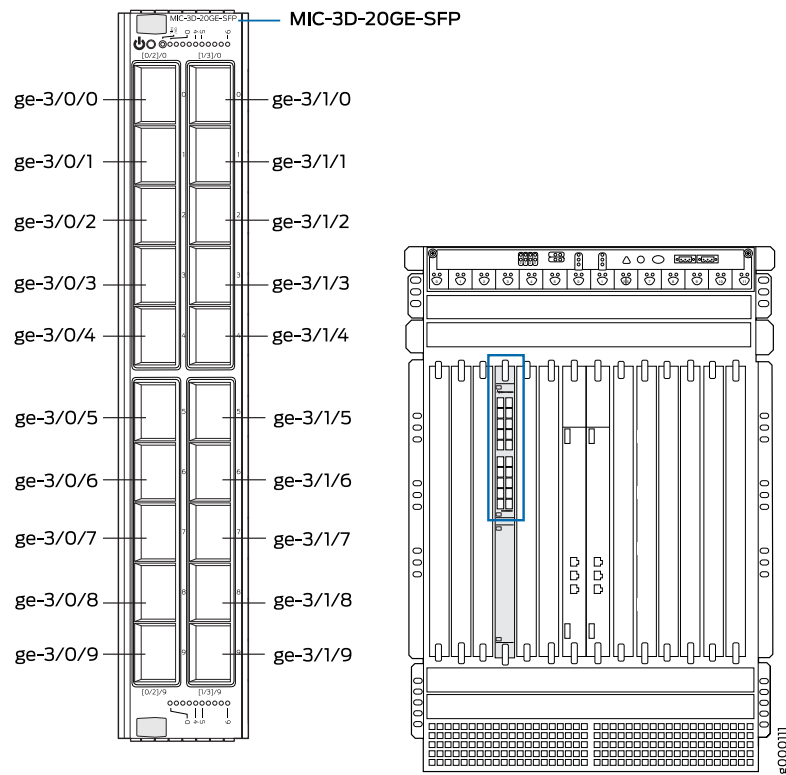
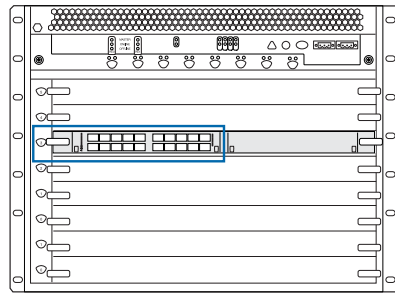

Figure 11: Port Numbering for the Gigabit Ethernet MIC with SFP (MX480)



MIC-3D-20GE-SFP

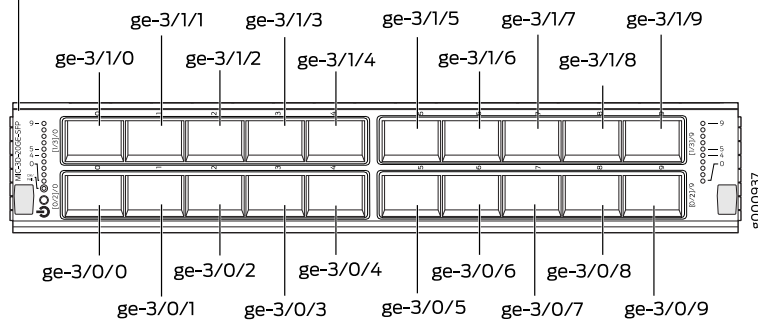
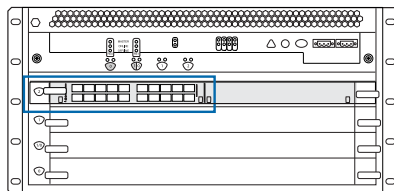
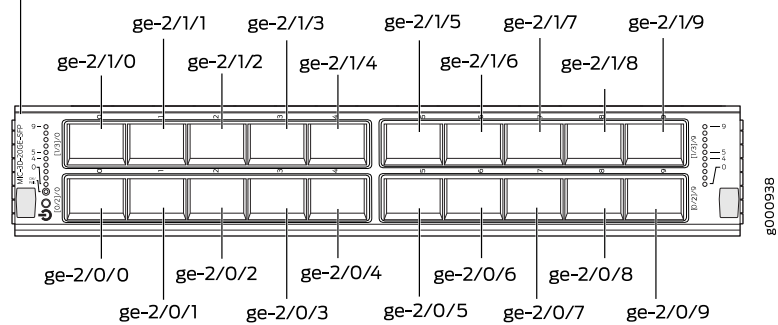

Figure 12: Port Numbering for Gigabit Ethernet MIC with SFP (MX240)



MIC-3D-20GE-SFP



Related Documentation

- [MX Series MIC Overview on page 17](#)

Gigabit Ethernet MIC with SFP (E)

Figure 13: 20-Port Gigabit Ethernet MIC with SFP (E)

MIC-3D-20GE-SFP-E

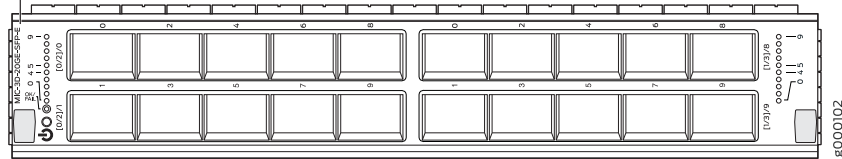

Software release	<ul style="list-style-type: none"> Junos 13.2R2 and later <p>For information on which MPCs support this MIC, see “MIC/MPC Compatibility” on page 21. For information on which MICs are supported on MX Series routers, see “MICs Supported by MX Series Routers” on page 17.</p>
Description	<ul style="list-style-type: none"> 20 Gigabit Ethernet ports Power requirement: 0.77 A @ 48 V (37 W) Weight: 1.2 lb (0.54 kg) Model number: MIC-3D-20GE-SFP-E Name in the CLI: 3D 20x 1GE(LAN)-E,SFP
Hardware features	<ul style="list-style-type: none"> High-performance throughput on each port at speeds up to 1 Gbps Auto-negotiation between Gigabit Ethernet circuit partners Up to 20-Gbps of full-duplex traffic Maximum transmission units (MTUs) of up to 9192 bytes Environmentally hardened for 32° F (0° C) to 131° F (55° C) operating temperatures SEC PHY Timing PHY
Software features	<ul style="list-style-type: none"> Optical diagnostics and related alarms Virtual Router Redundancy Protocol (VRRP) support IEEE 802.1Q virtual LANs (VLANs) support Remote monitoring (RMON) EtherStats Source MAC learning MAC accounting and policing—Dynamic local address learning of source MAC addresses Flexible Ethernet encapsulation Multiple tag protocol identifiers (TPID) Precision Time Protocol (PTP) or IEEE 1588v2 Media Access Control Security (MACsec)

Interfaces

Syntax: *ge-fpc/pic/port* where:

- fpc: Slot in the router where the MPC is installed. The MPCs are represented in the CLI as **FPC0** through **FPC19**.
- pic: The logical PIC number on the MIC, numbered 0 or 1. [Figure 14 on page 205](#), [Figure 15 on page 206](#), and [Figure 16 on page 206](#) illustrate the port numbering for the Gigabit Ethernet MIC with SFP (E) installed in the MX960, MX480, and MX240, respectively.
- port: 0 through 9.

For example, *ge-3/1/0* is the interface for port 0 in PIC 1 on the MPC installed in slot 3.

[Figure 14 on page 205](#), [Figure 15 on page 206](#), and [Figure 16 on page 206](#) illustrate the port numbering for the MIC-3D-20GE-SFP-E installed in an MX960, MX480, and MX280, respectively.

Cables and connectors

- Fiber-optic small form-factor pluggable (SFP) transceivers:

- Connector: Duplex LC/PC (Rx and Tx)
- 100BASE-FX (model number: SFP-IFE-FX)
- 1000BASE-LH (model number: SFP-IGE-LH)
- 1000BASE-LX (model number: SFP-IGE-LX)
- 1000BASE-SX (model number: SFP-IGE-SX)
- 1000BASE-SX (model number: SFP-GE40KM)

Optical interface specifications—see “[Fast Ethernet 100BASE-FX Optical Interface Specifications](#)” on page 48 and “[Gigabit Ethernet 1000BASE Optical Interface Specifications](#)” on page 44

- Copper SFP transceivers:

- Connector: Four-pair, Category 5 shielded twisted-pair connectivity through an RJ-45 connector
- 1000BASE-T (model number: SFP-IGE-T)
- 10/100/1000BASE-T (model number: SFP-IGE-FE-E-T)

NOTE: SFP-IGE-FE-E-T supports tri-rate 10/100/1000 mode in Junos OS Release 9.4 and later.

- Pinout: MDI, MDI crossover
- Length: 328 ft/100 m

Copper interface specifications—see “[Ethernet 10BASE-T Copper Interface Specifications](#)” on page 48, “[Fast Ethernet 100BASE-T Copper Interface Specifications](#)” on page 49, and “[Gigabit Ethernet 1000BASE-T Copper Interface Specifications](#)” on page 47

- Bidirectional SFP transceivers:

- Connector: Duplex LC/PC (Rx and Tx)
- 100BASE-BX (model number pairs: SFP-FE20KT13R15, SFP-FE20KT15R13)
- 1000BASE-BX (model number pairs: SFP-GE10KT13R14, SFP-GE10KT14R13, SFP-GE10KT13R15, SFP-GE10KT15R13, SFP-GE40KT13R15, SFP-GE40KT15R13)

Optical interface specifications—see “[Fast Ethernet and Gigabit Ethernet Bidirectional SFP Optical Interface Specifications](#)” on page 50

LEDs

OK/FAIL LED, one bicolor:

- Green—MIC is functioning normally.
- Red—MIC has failed.

Link LED, one green per port:

- Off—No link.
- On steadily—Link is up.

Figure 14: Port Numbering for the MIC-3D-20GE-SFP-E (MX960)

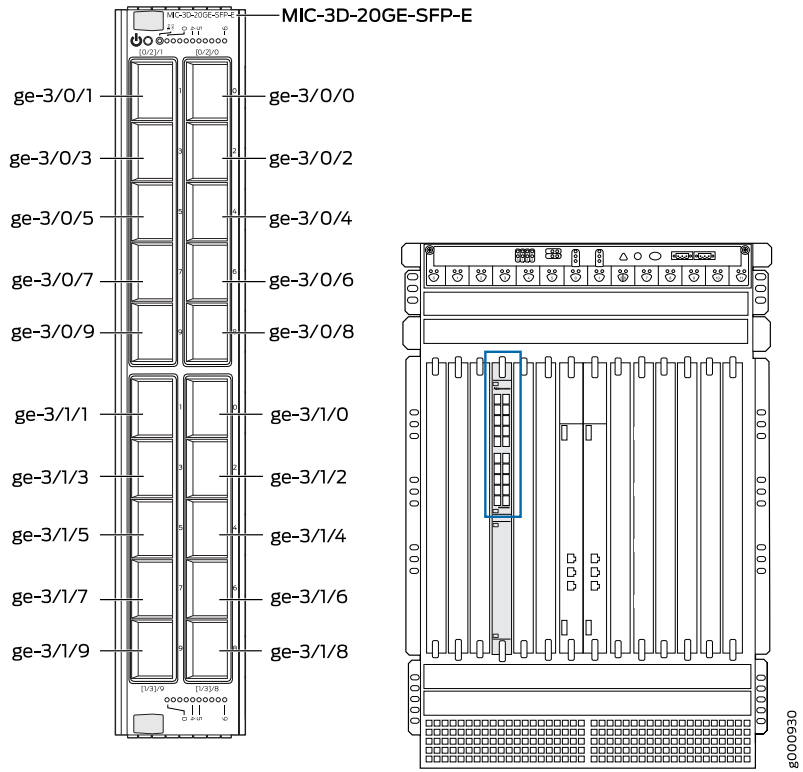
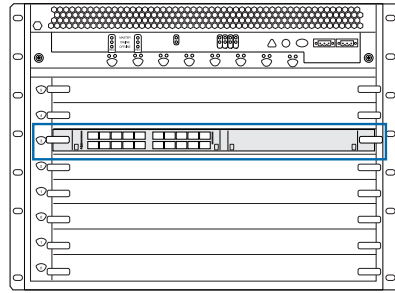

Figure 15: Port Numbering for the MIC-3D-20GE-SFP-E (MX480)



MIC-3D-20GE-SFP-E

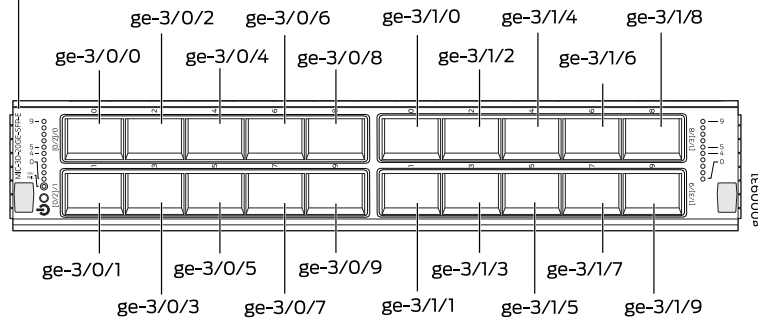
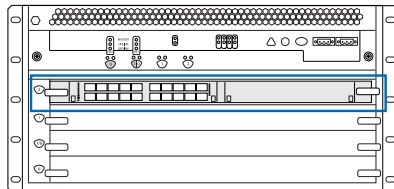
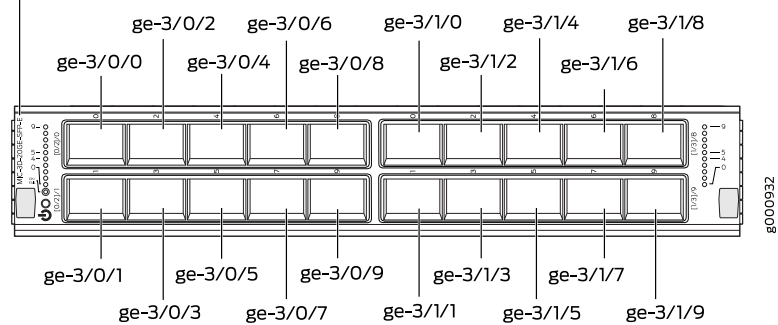

Figure 16: Port Numbering for the MIC-3D-20GE-SFP-E (MX240)



MIC-3D-20GE-SFP-E



Related Documentation • [MX Series MIC Overview on page 17](#)

Gigabit Ethernet MIC with SFP (EH)

Figure 17: 20-Port Gigabit Ethernet MIC with SFP (EH)

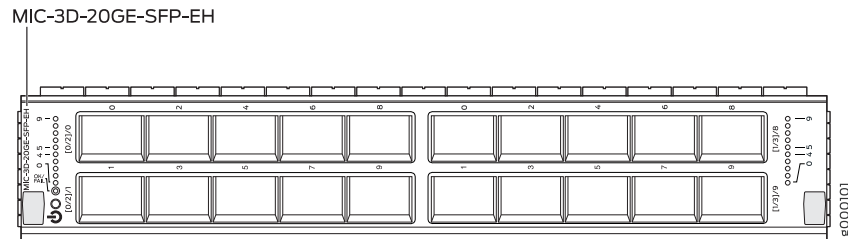

Software release	<ul style="list-style-type: none"> Junos 13.2R2 and later <p>For information on which MPCs support this MIC, see “MIC/MPC Compatibility” on page 21. For information on which MICs are supported on MX Series routers, see “MICs Supported by MX Series Routers” on page 17.</p>
Description	<ul style="list-style-type: none"> 20 Gigabit Ethernet ports Power requirement: 0.77 A @ 48 V (37 W) Weight: 1.2 lb (0.54 kg) Model number: MIC-3D-20GE-SFP-EH Name in the CLI: 3D 20x 1GE(LAN)-EH,SFP
Hardware features	<ul style="list-style-type: none"> High-performance throughput on each port at speeds up to 1 Gbps Autonegotiation between Gigabit Ethernet circuit partners Up to 20-Gbps of full-duplex traffic Maximum transmission units (MTUs) of up to 9192 bytes Environmentally hardened for -40° F (-40° C) to 149° F (65° C) operating temperatures SEC PHY Timing PHY
Software features	<ul style="list-style-type: none"> Optical diagnostics and related alarms Virtual Router Redundancy Protocol (VRRP) support IEEE 802.1Q virtual LANs (VLANs) support Remote monitoring (RMON) EtherStats Source MAC learning MAC accounting and policing—Dynamic local address learning of source MAC addresses Flexible Ethernet encapsulation Multiple tag protocol identifiers (TPID) Precision Time Protocol (PTP) or IEEE 1588v2 Media Access Control Security (MACsec)

Interfaces

Syntax: *ge-fpc/pic/port* where:

- fpc: Slot in the router where the MPC is installed
- pic: 0 (left grouping of 10 ports) or 1 (right grouping of 10 ports) when installed in MIC slot 0; 2 (left grouping of 10 ports) or 3 (right grouping of 10 ports) when installed in MIC slot 1
- port: 0 through 9

For example, *ge-1/3/0* is the interface for port 0 in the right grouping of ports on the MIC installed in MIC slot 1 on an MPC installed in slot 1.

Cables and connectors

- Fiber-optic small form-factor pluggable (SFP) transceivers:
 - Connector: Duplex LC/PC (Rx and Tx)
 - 1000BASE-LH (model number: SFP-1GE-LH)
 - 1000BASE-LX (model number: SFP-1GE-LX)
 - 1000BASE-SX (model number: SFP-1GE-SX)
 - 1000BASE-SX (model number: SFP-GE40KM)

Optical interface specifications—see [“Gigabit Ethernet 1000BASE Optical Interface Specifications” on page 44](#)

- Copper SFP transceivers:
 - Connector: Four-pair, Category 5 shielded twisted-pair connectivity through an RJ-45 connector
 - 1000BASE-T (model number: SFP-1GE-T)
 - 10/100/1000BASE-T (model number: SFP-1GE-FE-E-T)

NOTE: SFP-1GE-FE-E-T supports tri-rate 10/100/1000 mode in Junos OS Release 9.4 and later.

 - Pinout: MDI, MDI crossover
 - Length: 328 ft/100 m

Copper interface specifications—see [“Ethernet 10BASE-T Copper Interface Specifications” on page 48](#), [“Fast Ethernet 100BASE-T Copper Interface Specifications” on page 49](#), and [“Gigabit Ethernet 1000BASE-T Copper Interface Specifications” on page 47](#)

LEDs

OK/FAIL LED, one bicolor:

- Green—MIC is functioning normally.
- Red—MIC has failed.

Link LED, one green per port:

- Off—No link.
- On steadily—Link is up.

**Related
Documentation**

- [MX Series MIC Overview on page 17](#)

10-Gigabit Ethernet MICs with XFP

Figure 18: 2-Port 10-Gigabit Ethernet MIC with XFP

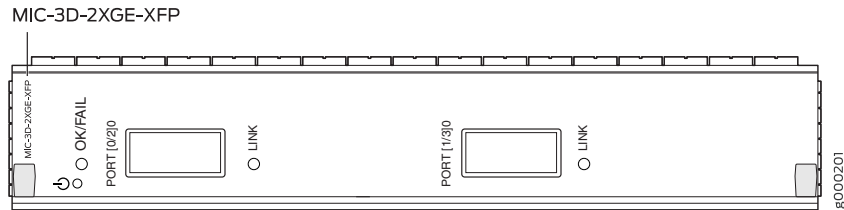
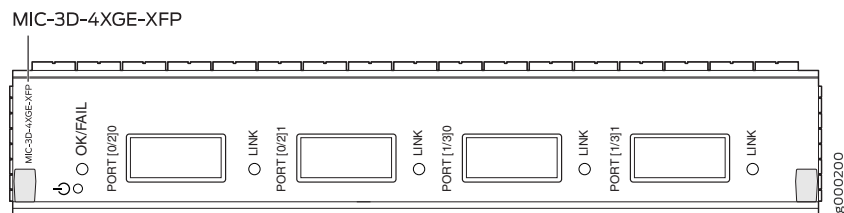

Figure 19: 4-Port 10-Gigabit Ethernet MIC with XFP



Software release

- 2-port: Junos 10.2 and later
- 4-port: Junos 10.1 and later

For information on which MPCs support these MICs, see [“MIC/MPC Compatibility” on page 21](#). For information on which MICs are supported on MX Series routers, see [“MICs Supported by MX Series Routers” on page 17](#).

Description

- Two or four 10-Gigabit Ethernet ports
- Power requirement:
 - 2-port: 0.6 A @ 48 V (29 W)
 - 4-port: 0.56 A @ 48 V (27 W)
- Weight:
 - 2-port: 1 lb (0.45 kg)
 - 4-port: 1.1 lb (0.5 kg)
- Model number:
 - 2-port: MIC-3D-2XGE-XFP
 - 4-port: MIC-3D-4XGE-XFP
- Name in the CLI:
 - 2-port: **3D 2X10GE XFP**
 - 4-port: **3D 4X10GE XFP**

Hardware features

- High-performance throughput on each port at speeds up to 10 Gbps
- LAN-PHY mode at 10.3125 Gbps
- WAN-PHY mode at 9.953 Gbps
- Maximum transmission units (MTUs) of up to 9192 bytes

- Software features
- Configurable LAN-PHY and WAN-PHY mode options
 - Synchronous Ethernet support
 - Optical diagnostics and related alarms
 - Virtual Router Redundancy Protocol (VRRP) support
 - IEEE 802.1Q virtual LANs (VLANs) support
 - Remote monitoring (RMON) EtherStats
 - Source MAC learning
 - MAC accounting and policing—Dynamic local address learning of source MAC addresses
 - Flexible Ethernet encapsulation
 - Multiple tag protocol identifiers (TPID)

Interfaces

Syntax: *xe-fpc/pic/port* where:

- fpc: Slot in the router where the MPC is installed
- pic:
 - 2-port: 0 when installed in MIC slot 0; 3 when installed in MIC slot 1
 - 4-port: 0 or 1 when installed in MIC slot 0; 2 or 3 when installed in MIC slot 1
- port:
 - 2-port: 0
 - 4-port: 0 or 1

For example, *xe-1/3/0* is the interface for port 0 on the MIC installed in MIC slot 1 on an MPC installed in slot 1.

Cables and connectors

- Fiber-optic 10-gigabit small form-factor pluggable (XFP) transceivers:
 - Connector: Duplex LC/PC (Rx and Tx)
 - 10GBASE-E (model number: XFP-10G-E-OC192-IR2)
 - 10GBASE-L (model number: XFP-10G-L-OC192-SR1)
 - 10GBASE-LR (model number: XFP-10G-LR)
 - 10GBASE-S (model number: XFP-10G-S)
 - 10GBASE-Z (model number: XFP-10G-Z-OC192-LR2)

Optical interface specifications—see ["10-Gigabit Ethernet 10GBASE Optical Interface Specifications" on page 54](#)
- DWDM Tunable XFP transceivers:
 - Connector: Duplex LC/PC (Rx and Tx)
 - 10GBASE-ZR (model number: XFP-10G-CBAND-T50-ZR)
DWDM supported wavelengths—see *10-Gigabit Ethernet DWDM Transceiver Wavelengths*

NOTE: XFP-10G-CBAND-T50-ZR is supported in Junos 10.2 and later

Optical interface specifications—see ["10-Gigabit Ethernet 10GBASE Optical Interface Specifications" on page 54](#)

LEDs	<p>OK/FAIL LED, one bicolor:</p> <ul style="list-style-type: none"> Green—MIC is functioning normally. Red—MIC has failed. <p>LINK LED, one green per port:</p> <ul style="list-style-type: none"> Off—No link. On steadily—Link is up with or without activity. <p>The ports are labeled:</p> <ul style="list-style-type: none"> 2-port: [0/2]0, [1/3]0 4-port: [0/2]0, [0/2]1, [1/3]0, and [1/3]1
------	---

Related Documentation

- [MX Series MIC Overview on page 17](#)

10-Gigabit Ethernet MIC with SFP+ (10 Ports)

Figure 20: 10-Gigabit Ethernet MIC with SFP+

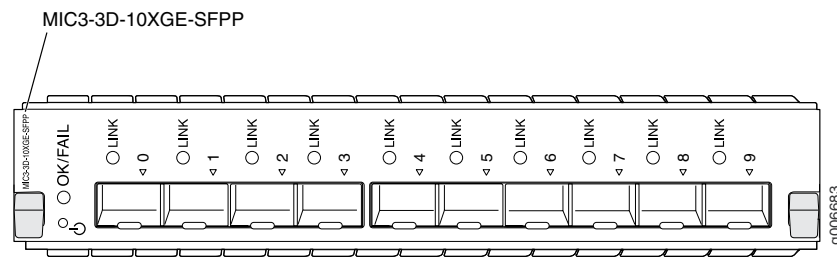

Software release	<ul style="list-style-type: none"> Junos 12.3 and later
Description	<ul style="list-style-type: none"> Ten 10-Gigabit Ethernet ports Power requirement: 0.62 A @ 48 V (29.8 W) Weight: 1.54 lb (0.70 kg) Model number: MIC3-3D-10XGE-SFPP Name in the CLI: 3D 10xGE SFPP
Hardware features	<ul style="list-style-type: none"> High-performance throughput on each port at speeds up to 10 Gbps Supports 10 SFP+ pluggable optic ports Voltage Sequencer for local voltage sequence control and monitoring LAN-PHY mode at 10.3125 Gbps WAN-PHY mode at 9.95328 Gbps Maximum transmission units (MTUs) of up to 9192 bytes

Software features	<ul style="list-style-type: none"> • Configurable LAN-PHY and WAN-PHY mode options per port • Synchronous Ethernet support • Optical diagnostics and related alarms • Virtual Router Redundancy Protocol (VRRP) support • IEEE 802.1Q virtual LANs (VLANs) support • Remote monitoring (RMON) EtherStats • Source MAC learning • MAC accounting and policing—Dynamic local address learning of source MAC addresses • Flexible Ethernet encapsulation • Multiple tag protocol identifiers (TPID)
Cables and connectors	<ul style="list-style-type: none"> • Fiber-optic 10-gigabit small form-factor pluggable (SFP+) transceivers: <ul style="list-style-type: none"> • Connector: Duplex LC • 10GBASE-SR (model number: SFPP-10GE-SR) • 10GBASE-LR (model number: SFPP-10GE-LR) • 10GBASE-ER (model number: SFPP-10GE-ER) • 10GBASE-ZR (model number: SFPP-10GE-ZR) <p>NOTE: SFPP-10GE-ZR has a commercial temperature rating and is not NEBS compliant when plugged into the 10-Gigabit Ethernet MIC with SFP+. If the ambient air temperature exceeds 40 degrees C, the software disables the transmitter, which takes the optical transceiver offline.</p> <ul style="list-style-type: none"> • 10GBASE-ZR (model number: SFPP-10G-OTN-XT) <ul style="list-style-type: none"> • Supported in Junos OS Release 12.3R5, 13.2R3, 13.3, and later • NEBS compliant • Dual-rate extended temperature transceiver that supports LAN-PHY and WAN-PHY modes, and OTN rates • 10GBASE-ZR (model number: SFPP-10G-DT-ZRC2) <ul style="list-style-type: none"> • Supported in Junos OS Release 12.3R6, 13.2R3, 13.3R2, 14.1R1, and later • Supports LAN-PHY and WAN-PHY modes • Is tunable by configuring the wavelength statement at the [edit interfaces interface-name optics-options] hierarchy level (see <i>wavelength</i>) <p>NOTE: SFPP-10G-DT-ZRC2 is not NEBS compliant when plugged into the MIC3-3D-10XGE-SFPP MIC. If the ambient air temperature exceeds 40 degrees C, Junos OS disables the transmitter, which takes the optical transceiver offline.</p> <p>Optical interface specifications—see “10-Gigabit Ethernet 10GBASE Optical Interface Specifications” on page 54</p>
LEDs	<p>OK/FAIL LED, one bicolor:</p> <ul style="list-style-type: none"> • Green—MIC is functioning normally. • Red—MIC has failed. <p>LINK LED, one per SFP+ port:</p> <ul style="list-style-type: none"> • Off—No link. • Green—Link is up. • Yellow—Link is disabled. <p>The ports are labeled:</p> <ul style="list-style-type: none"> • Port [0] to Port [9]

- Related Documentation**
- [MX Series MIC Overview on page 17](#)
 - [MICs Supported by MX Series Routers on page 17](#)
 - [MIC/MPC Compatibility on page 21](#)

10-Gigabit Ethernet MIC with SFP+ (24 Ports)

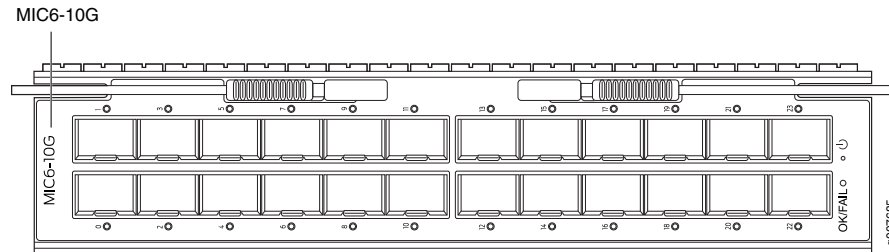

Software release	<ul style="list-style-type: none"> • Junos 13.3R2 and later <p>For information about which MPCs support this MIC, see "MIC/MPC Compatibility" on page 21. For information about which MICs are supported on MX Series routers, see "MICs Supported by MX Series Routers" on page 17.</p>
Description	<ul style="list-style-type: none"> • Twenty-four 10-Gigabit Ethernet ports • Power requirement: 7.1 A @ 10.4 V (74 W) • Weight: 3.2 lb (1.45 kg) • Model number: MIC6-10G • Name in the CLI: 24x10GE SFPP
Hardware features	<ul style="list-style-type: none"> • Supports 24 SFP+ pluggable optic ports • High-performance throughput on each port at speeds up to 10 Gbps • LAN-PHY mode at 10.3125 Gbps • WAN-PHY mode at 9.95328 Gbps • Supports LOS-squelch, enabling Synchronous Ethernet fast-clock-failover on a port down event • Maximum transmission units (MTUs) of up to 9192 bytes
Software features	<ul style="list-style-type: none"> • Configurable LAN-PHY and WAN-PHY mode options per port • Compliant to ITU-T specifications • Optical diagnostics and related alarms • Virtual Router Redundancy Protocol (VRRP) support • IEEE 802.1Q virtual LANs (VLANs) support • IEEE 802.1ad support • Remote monitoring (RMON) EtherStats • Source MAC learning • MAC accounting and policing—Dynamic local address learning of source MAC addresses • In-service software upgrade (Unified ISSU)

- Cables and connectors
- Fiber-optic 10-gigabit small form-factor pluggable (SFP+) transceivers:
 - Connector: Duplex LC
 - 10GBASE-SR (model number: SFPP-10GE-SR)
 - 10GBASE-LR (model number: SFPP-10GE-LR)
 - 10GBASE-ER (model number: SFPP-10GE-ER-XT)
 - 10GBASE-ZR (model number: SFPP-10G-ZR-OTN-XT)
- Optical interface specifications—see [“10-Gigabit Ethernet 10GBASE Optical Interface Specifications” on page 54](#)

- LEDs
- OK/FAIL LED**, one bicolor:
- Green—MIC is functioning normally.
 - Yellow—MIC is coming online.
 - Red—MIC has failed.
- LINK LED**, one bicolor per SFP+ port:
- Off—No link.
 - Green—Link is up.
 - Yellow—Link is disabled.
- The ports are labeled:
- Port [0] to Port [23]

- Related Documentation**
- [MX Series MIC Overview on page 17](#)

10-Gigabit Ethernet OTN MIC with SFP+ (24 Ports)

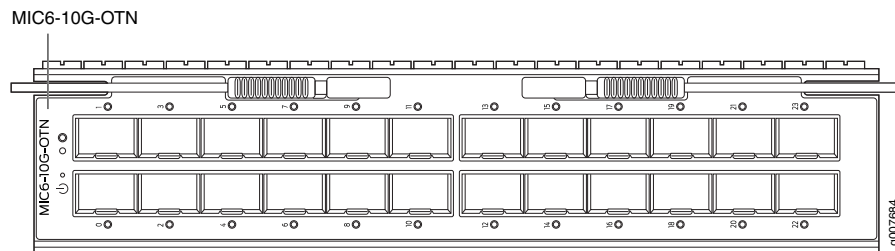

- Software release
- Junos 13.3R3 and later
- For information about which MPCs support this MIC, see [“MIC/MPC Compatibility” on page 21](#). For information about which MICs are supported on MX Series routers, see [“MICs Supported by MX Series Routers” on page 17](#).

- Description
- Twenty-four 10-Gigabit optical transport network (OTN) ports for transport of 10-Gigabit Ethernet (10GBASE-R) traffic
 - Power requirement: 1.5 A @ 52 V (84 W)
 - Weight: 3.4 lb (1.54 kg)
 - Model number: MIC6-10G-OTN
 - Name in the CLI: **24x10GE OTN**

Hardware features	<ul style="list-style-type: none"> • High-performance throughput on each port at speeds up to 10 Gbps • LAN-OTU2e mode (G.Sup43, 7.1) at 11.09 Gbps • WAN-OTU2 mode (G.Sup43, 6.1) at 10.70 Gbps • Supports LOS-squelch, enabling Synchronous Ethernet fast-clock-failover on a port-down event • Provides IEEE 1588 time-stamping at physical interface for improved accuracy • Maximum transmission units (MTUs) of up to 9192 bytes
Software features	<ul style="list-style-type: none"> • OTN support for 10-Gigabit Ethernet interface • Compliant with ITU-T specifications • Transparent transport of 10-Gigabit Ethernet signals with optical channel transport unit 2 (OTU2/OTU2e) framing • Optical diagnostics and related alarms • Configurable LAN-PHY, WAN-PHY, or OTN mode options per port • Virtual Router Redundancy Protocol (VRRP) support • IEEE 802.1Q VLAN support • IEEE 802.1ad support • Remote monitoring (RMON) EtherStats • Source MAC learning • MAC accounting and policing—Dynamic local address learning of source MAC addresses • In-service software upgrade (Unified ISSU)
Cables and connectors	<ul style="list-style-type: none"> • Duplex LC connector • Small Form-Factor Pluggable (SFPP) transceiver • Support for LAN and WAN rates over -SR, -LR, -ER, -ZR optics • Support for OTN rates over -LR and -ZR optics • Support for tunable (DWDM) wavelengths at LAN/WAN/OTN rates over -ZR optics <p>Optical interface specifications—see “10-Gigabit Ethernet DWDM OTN Optical Interface Specifications” on page 59 and “10-Gigabit Ethernet 10GBASE Optical Interface Specifications” on page 54.</p>
LEDs	<p>OK/FAIL LED, one bicolor:</p> <ul style="list-style-type: none"> • Green—MIC is functioning normally. • Yellow—MIC is coming online. • Red—MIC has failed. <p>LINK LED, one bicolor per port:</p> <ul style="list-style-type: none"> • Off—No link. • Green—Link is up. • Yellow—Link is disabled. <p>The ports are labeled:</p> <ul style="list-style-type: none"> • Port [0] through Port [23]

Related Documentation

- [MX Series MIC Overview on page 17](#)

40-Gigabit Ethernet MIC with QSFP+

Figure 21: 40-Gigabit Ethernet MIC with QSFP+

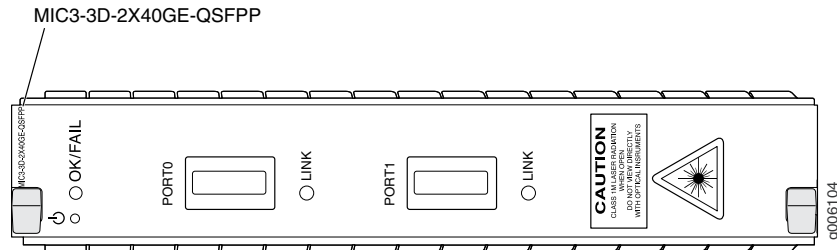

Software release	<ul style="list-style-type: none"> 12.2 and later <p>For information on which MPCs support this MIC, see “MIC/MPC Compatibility” on page 21. For information on which MICs are supported on MX Series routers, see “MICs Supported by MX Series Routers” on page 17.</p>
Description	<ul style="list-style-type: none"> Two 40-Gigabit Ethernet ports Power requirement: 0.38 A @ 48 V (18 W) Weight: 1.19 lb (0.54 kg) Model number: MIC3-3D-2X40GE-QSFPP
Hardware features	<ul style="list-style-type: none"> High-performance throughput on each port at speeds up to 40 Gbps Up to 40-Gbps of full-duplex traffic Maximum transmission units (MTUs) of up to 9192 bytes
Software features	<ul style="list-style-type: none"> Synchronous Ethernet support Optical diagnostics and related alarms Virtual Router Redundancy Protocol (VRRP) support IEEE 802.1Q virtual LANs (VLANs) support Remote monitoring (RMON) EtherStats Source MAC learning MAC accounting and policing—Dynamic local address learning of source MAC addresses Flexible Ethernet encapsulation Multiple tag protocol identifiers (TPID)
Cables and connectors	<ul style="list-style-type: none"> Fiber-optic 40-gigabit quad small form-factor pluggable plus (QSFP+) <ul style="list-style-type: none"> Connector: 12-fiber MPO 40GBASE-SR4 (model number: QSFPP-40GBASE-SR4) Connector: Standard Duplex LC 40GBASE-LR4 (model number: QSFPP-40GBASE-LR4) 40GBASE-ER4 (model number: QSFPP-40GBASE-ER4) Connector: Female, MPO-UPC 10GBASE-SR (model number: QSFPP-4X10GE-SR) Connector: Female, MPO-APC (angled 8 degrees) 10GBASE-LR (model number: QSFPP-4X10GE-LR) <p>Optical interface specifications—see “40-Gigabit Ethernet 40GBASE-R Optical Interface Specifications” on page 64 and “10-Gigabit Ethernet 10GBASE-R Optical Interface Specifications” on page 54.</p>

LEDs	<p>OK/FAIL LED, one bicolor:</p> <ul style="list-style-type: none"> Green—MIC is functioning normally. Red—MIC has failed. <p>LINK LED, one green per port:</p> <ul style="list-style-type: none"> Off—No link. On steadily—Link is up with or without activity. Yellow—Link is disabled. <p>The ports are labeled:</p> <ul style="list-style-type: none"> PORT [0] - PORT [1]
------	---

Related Documentation

- [MX Series MIC Overview on page 17](#)

100-Gigabit Ethernet MIC with CFP

Figure 22: 1-Port 100 Gigabit Ethernet MIC with CFP

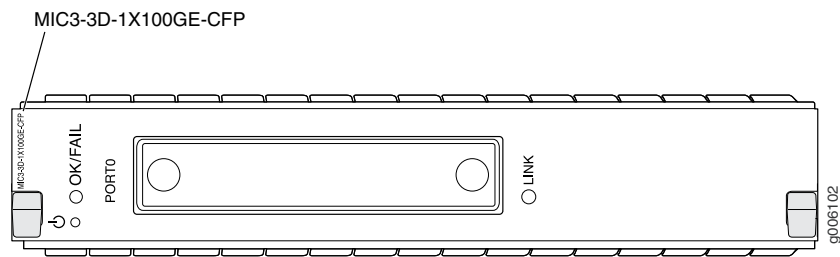

Software release	<ul style="list-style-type: none"> 12.1 and later <p>For information about which MPCs support this MIC, see “MIC/MPC Compatibility” on page 21. For information about which MICs are supported on MX Series routers, see “MICs Supported by MX Series Routers” on page 17.</p>
Description	<ul style="list-style-type: none"> One 100-Gigabit Ethernet port Power requirement: 0.83 A @ 48 V (40 W) Weight: 1.94 lb (0.88 kg) Model number: MIC3-3D-1X100GE-CFP Name in the CLI: 1X100GE CFP
Hardware features	<ul style="list-style-type: none"> High-performance throughput on each port at speeds up to 100 Gbps Up to 100-Gbps of full-duplex traffic Maximum transmission units (MTUs) of up to 9192 bytes The port is labeled PORT0

Software features	<ul style="list-style-type: none"> • Synchronous Ethernet support • Optical diagnostics and related alarms • Virtual Router Redundancy Protocol (VRRP) support • IEEE 802.1Q virtual LANs (VLANs) support • Remote monitoring (RMON) EtherStats • Source MAC learning • MAC accounting and policing—Dynamic local address learning of source MAC addresses • Flexible Ethernet encapsulation • Multiple tag protocol identifiers (TPID)
Cables and connectors	<ul style="list-style-type: none"> • Fiber-optic 100-Gigabit C form-factor Pluggable <ul style="list-style-type: none"> • 100GBASE-LR4 (model number: CFP-100GBASE-LR4). Connector: Duplex SC/PC (Rx and Tx) • 100GBASE-LR4 (model number: CFP-GEN2-100GBASE-LR4 and part number: 740-047682). Connector: Duplex LC/PC (Rx and Tx) • 100GBASE-ER4 (model number: CFP-100GBASE-ER4). Connector: Duplex LC/PC <p>NOTE: The CFP-100GBASE-ER4 transceiver is NEBS-compliant in the 100-Gigabit Ethernet MIC with CFP, but only when the other MIC slot in the MPC3E is empty. If another MIC is present and the ambient temperature exceeds 40 degrees C, the software converts CFP-100GBASE-ER4 to low power mode, which takes the transceiver offline.</p> <ul style="list-style-type: none"> • 100GBASE-ER4 (model number: CFP-GEN2-CGE-ER4 and part number: 740-049763). Connector: Duplex LC <p>NOTE: The “GEN2” optics have been redesigned with newer versions of internal components for reduced power consumption.</p> <ul style="list-style-type: none"> • 100GBASE-SR10 (model number: CFP-100GBASE-SR10). Connector: 24-fiber MPO • 100GBASE-ZR (model number: CFP-100GBASE-ZR). Connector: LC <ul style="list-style-type: none"> • Supported in Junos OS Release 13.3R6, 14.1R4, 14.2R3, and 15.1R1 and later • Provides advanced dual polarization-quadrature phase-shift keying (DP-QPSK) coherent digital signal processing (DSP) and forward error correction (FEC)-enabled robust tolerance to optical impairments and supports 80 km reach over single mode fiber • The transceiver is not specified as part of IEEE 802.3 but is built according to Juniper Networks specifications. <p>NOTE: The CFP-100GBASE-ZR transceiver is NEBS compliant in the 100-Gigabit Ethernet MIC with CFP, but only when the other MIC slot in the MPC3E is empty. If another MIC is present and the ambient air temperature exceeds 40 degrees C, the software disables the transmitter, which takes the optical transceiver offline. The other MIC slot must be filled with a blank panel.</p> <p>Optical interface specifications—see “100-Gigabit Ethernet 100GBASE-R Optical Interface Specifications” on page 68</p>
LEDs	<p>OK/FAIL LED, one bicolor:</p> <ul style="list-style-type: none"> • Green—MIC is functioning normally. • Red—MIC has failed. <p>LINK LED, one green per port:</p> <ul style="list-style-type: none"> • Off—No link. • On steadily—Link is up. • Yellow—Link is disabled.

- Related Documentation**
- [MX Series MIC Overview on page 17](#)

100-Gigabit Ethernet MIC with CXP

Figure 23: 100-Gigabit Ethernet MIC with CXP

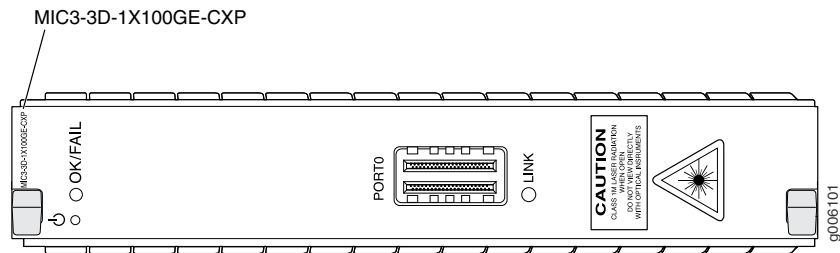

Software release	<ul style="list-style-type: none"> • 12.2 and later <p>For information about which MPCs support this MIC, see “MIC/MPC Compatibility” on page 21. For information about which MICs are supported on MX Series routers, see “MICs Supported by MX Series Routers” on page 17.</p>
Description	<ul style="list-style-type: none"> • One 100-gigabit Ethernet port • Power requirement: 0.42 A @ 48 V (20 W) • Weight: 1.03 lb (0.47 kg) • Model number: MIC3-3D-1X100GE-CXP • Name in the CLI: 3D 1x100GE CXP
Hardware features	<ul style="list-style-type: none"> • High-performance throughput on each port at speeds up to 100 Gbps • Up to 100-Gbps of full-duplex traffic • Maximum transmission units (MTUs) of up to 9192 bytes • The port is labeled PORT0
Software features	<ul style="list-style-type: none"> • Synchronous Ethernet support • Optical diagnostics and related alarms • Virtual Router Redundancy Protocol (VRRP) support • IEEE 802.1Q virtual LANs (VLANs) support • Remote monitoring (RMON) EtherStats • Source MAC learning • MAC accounting and policing—Dynamic local address learning of source MAC addresses • Flexible Ethernet encapsulation • Multiple tag protocol identifiers (TPID)
Cables and connectors	<ul style="list-style-type: none"> • Fiber-optic 100-gigabit CXP <ul style="list-style-type: none"> • Connector: 24-fiber MPO • 100GBASE-SR10 (model number: CXP-100GBASE-SR10) <p>Optical interface specifications—see “100-Gigabit Ethernet 100GBASE-R Optical Interface Specifications” on page 68</p>

LEDs	<p>OK/FAIL LED, one bicolor:</p> <ul style="list-style-type: none"> Green—MIC is functioning normally. Red—MIC has failed. <p>LINK LED, one green per port:</p> <ul style="list-style-type: none"> Off—No link. On steadily—Link is up with or without activity. Yellow—Link is disabled.
------	--

Related Documentation

- [MX Series MIC Overview on page 17](#)

100-Gigabit Ethernet MIC with CXP (4 Ports)

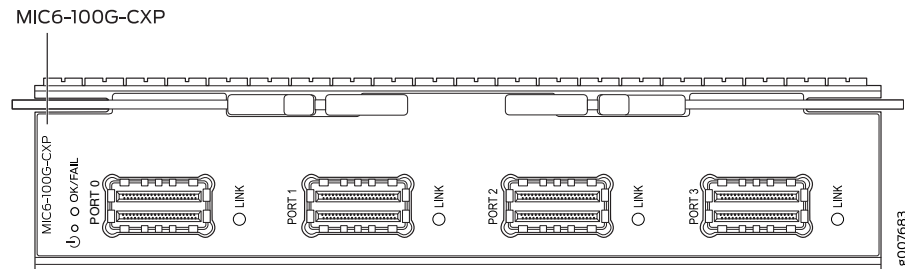

Software release	<ul style="list-style-type: none"> • Junos 13.3R2 and later <p>For information about which MPCs support this MIC, see “MIC/MPC Compatibility” on page 21. For information about which MICs are supported on MX Series routers, see “MICs Supported by MX Series Routers” on page 17.</p>
Description	<ul style="list-style-type: none"> • Four 100-Gigabit Ethernet ports • Power requirement: 5.5 A @ 10.4 V (57 W) • Weight: 2.7 lb (1.22 kg) • Model number: MIC6-100G-CXP • Name in the CLI: 4X100GE CXP
Hardware features	<ul style="list-style-type: none"> • Line-rate throughput of up to 100Gbps per port. • Supports 100GBASE-SR10 over CXP pluggable optics • Supports LOS-squelch, enabling Synchronous Ethernet fast-clock-failover on a port down event • Maximum transmission units (MTUs) of up to 9192 bytes

Software features	<ul style="list-style-type: none"> Compliant to ITU-T specifications Optical diagnostics and related alarms Virtual Router Redundancy Protocol (VRRP) support IEEE 802.1Q virtual LANs (VLANs) support IEEE 802.1ad support Remote monitoring (RMON) EtherStats Source MAC learning MAC accounting and policing—Dynamic local address learning of source MAC addresses In-service software upgrade (Unified ISSU)
Cables and connectors	<ul style="list-style-type: none"> Fiber-optic 100-gigabit CXP <ul style="list-style-type: none"> Connector: 24-fiber MPO 100GBASE-SR10 (model number: CXP-100GBASE-SR10) optical interface specifications—see “100-Gigabit Ethernet 100GBASE-R Optical Interface Specifications” on page 68
LEDs	<p>OK/FAIL LED, one tricolor:</p> <ul style="list-style-type: none"> Green—MIC is functioning normally. Yellow—MIC is coming online. Red—MIC has failed. <p>LINK LED, one bicolor per port:</p> <ul style="list-style-type: none"> Off—No link. Green—Link is up. Yellow—Link is disabled. <p>The ports are labeled:</p> <ul style="list-style-type: none"> Port 0 to Port 3

Related Documentation

- [MX Series MIC Overview on page 17](#)

100-Gigabit Ethernet MIC with CFP2

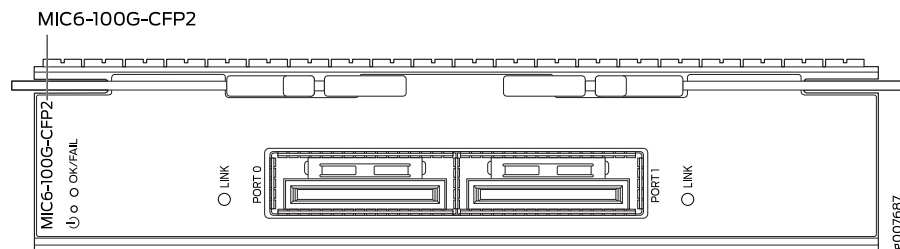

Software release	<ul style="list-style-type: none"> Junos 13.3R3 and later <p>For information about which MPCs support this MIC, see “MIC/MPC Compatibility” on page 21. For information about which MICs are supported on MX Series routers, see “MICs Supported by MX Series Routers” on page 17.</p>
------------------	---

Description	<ul style="list-style-type: none">• Two 100-Gigabit Ethernet CFP2 ports• Power requirement: 2 A @ 52 V (104 W)• Weight: 2.4 lb (1.09 kg)• Model number: MIC6-100G-CFP2• Name in the CLI: 2X100GE CFP2 OTN
Hardware features	<ul style="list-style-type: none">• Line-rate throughput of up to 100 Gbps per port• Supports CFP2 pluggable optics• Supports LAN (103.125 Gbps) and OTN/OTU4 (111.81 Gbps) on a per-port basis• Provides IEEE 1588 time-stamping at physical interface for improved accuracy• Maximum transmission units (MTUs) of up to 9192 bytes
Software features	<ul style="list-style-type: none">• Optical transport network (OTN) support for 100-Gigabit Ethernet interfaces• Compliant with ITU-T specifications• Transparent transport of 100-Gigabit Ethernet signals with OTU4 framing• Optical diagnostics and related alarms• Configurable 100-Gigabit Ethernet or OTN options per port• Virtual Router Redundancy Protocol (VRRP) support• IEEE 802.1Q VLAN support• IEEE 802.1ad support• Remote monitoring (RMON) EtherStats• Source MAC learning• MAC accounting and policing—Dynamic local address learning of source MAC addresses• In-service software upgrade (Unified ISSU)
Cables and connectors	<p>Fiber-optic 100-gigabit CFP2 transceivers</p> <ul style="list-style-type: none">• Connector: Duplex LC• 100GBASE-LR4 (model numbers: CFP2-100GBASE-LR4 for LAN rates and CFP2-100G-LR4-D for LAN/OTN rates)• 100GBASE-ER4 (model numbers: CFP2-100GBASE-ER4 for LAN rates and CFP2-100G-ER4-D for LAN/OTN rates) <p>NOTE: CFP2-100G-ER4-D is not NEBS compliant on the MX960 router in FPC slot 0 or FPC slot 11.</p> <ul style="list-style-type: none">• 100GBASE-SR10 (model numbers: CFP2-100GBASE-SR10 for LAN rates and CFP2-100G-SR10-D3 for LAN/OTN rates; also see "Cable Specifications for MX Series Transceivers" on page 43) <p>For optical interface specifications, see "100-Gigabit Ethernet 100GBASE-R Optical Interface Specifications" on page 68.</p> <p>NOTE: When inserting the CFP2 transceiver, ensure that the transceiver sits tightly in the port. You will hear a distinct click sound when the latch locks into the corresponding port. The latch must be fully engaged in the corresponding port for the CFP2 transceiver to function properly. Failing to do so will result in loss of connection.</p> <p>To verify that the CFP2 transceiver module is inserted properly, give a gentle pull by grasping the sides of the module. The module should sit tightly.</p>

LEDs	<p>OK/FAIL LED, one tricolor:</p> <ul style="list-style-type: none"> Green—MIC is functioning normally. Yellow—MIC is coming online. Red—MIC has failed. <p>LINK LED, one bicolor per port:</p> <ul style="list-style-type: none"> Off—No link. Green—Link is up. Yellow—Link is disabled. <p>Port labels:</p> <ul style="list-style-type: none"> Port 0 and Port 1
------	--

Related Documentation

- [MX Series MIC Overview on page 17](#)

100-Gigabit DWDM OTN MIC with CFP2-ACO

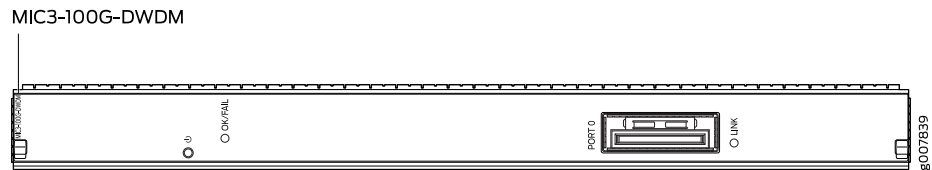

Software release	<ul style="list-style-type: none"> Junos 15.1F5 and later <p>For information about which MPCs support this MIC, see "MIC/MPC Compatibility" on page 21. For information about which MICs are supported on MX Series routers, see "MICs Supported by MX Series Routers" on page 17.</p>
Description	<ul style="list-style-type: none"> One 100-Gigabit DWDM OTN port Power requirements (including transceiver) at different temperatures: <ul style="list-style-type: none"> 55° C: 1.90 A @ 48 V (91 W) 25° C: 1.73 A @ 48 V (83 W) Weight: 2.3 lb (1.04 kg) Model number: MIC3-100G-DWDM Name in the CLI: 1X100GE DWDM CFP2-ACO

Hardware features

- Dual-wide MIC that installs into two MIC slots
- Supports CFP2 analog coherent optics (CFP2-ACO)
- Transparent transport of a 100-Gigabit Ethernet signal with OTU4V framing
- ITU-standard OTN performance monitoring and alarm management
- Dual-polarization quadrature phase shift keying (DP-QPSK) modulation
- Supports three types of forward error correction (FEC):
 - Soft-decision FEC (SD-FEC)
 - High-gain FEC (HG-FEC)
 - G.709 FEC (GFEC)
- 100 channels on C-band ITU grid with 50-GHz spacing
- Latency:
 - SD-FEC: 14 μ s (TX + RX)
 - HG-FEC: 22 μ s (TX + RX)
 - GFEC: 6 μ s (TX + RX)
- Interoperable with the CFP-100GBASE-ZR transceiver supported on the 100-Gigabit Ethernet MIC with CFP (MIC3-3D-1X100GE-CFP) on MX Series routers and the 100-Gigabit Ethernet PIC with CFP (P1-PTX-2-100GE-CFP) on PTX Series routers.
- Interoperable with the 100-Gigabit DWDM OTN PIC with CFP2 (PTX-5-100G-WDM) on PTX Series routers when the 100-Gigabit DWDM OTN MIC is configured to use SD-FEC or GFEC.

NOTE: The 1-port 100-Gigabit DWDM OTN MIC is not directly interoperable with the 2-port 100-Gigabit DWDM OTN PIC (P1-PTX-2-100G-WDM), but they can both operate over the same DWDM line system.

Software features

NOTE: For information about configuring the MIC, see [Configuring OTN Interfaces on MIC3-100G-DWDM MIC](#). For information about upgrading the firmware on the PIC, see [Upgrading Firmware on the 100-Gigabit DWDM OTN MIC \(MIC3-100G-DWDM\)](#).

- Compliant with ITU G.709 and G.798
 - Provides a transport interface and state model (GR-1093)
 - Performance monitoring features such as alarms, threshold-crossing alarms, OTU/ODU error seconds and FEC and bit error rate (BER) statistics
 - SNMP management of the MIC based on *RFC 3591, Managed Objects for the Optical Interface Type*, including the following:
 - Set functionality
 - Black Link MIB
 - IFOTN MIB
 - Optics MIB
 - FRU MIB
 - Pre-FEC BER monitoring provides interrupt-driven, BER-based detection of link signal degradation for MPLS fast reroute.
 - User-configurable optics options:
 - Transmit (TX) laser enable and disable
 - TX output power
 - Wavelength
 - Receive (RX) LOS warning or alarm thresholds
 - Threshold crossing alarms (TCAs)
- User-configurable card options:
- FEC mode (SD-FEC, HG-FEC, or GFEC)
 - TCAs

Cables and connectors

Fiber-optic 100-gigabit CFP2-ACO transceiver

- Connector: Duplex LC/UPC
- Model number: TCFP2-100G-C

For optical interface specifications, see ["100-Gigabit DWDM OTN CFP2-ACO Optical Interface Specifications"](#) on page 72.

NOTE: When inserting the C form-factor pluggable 2 (CFP2) transceiver, ensure that the transceiver sits tightly in the port. You hear a distinct click sound when the latch locks into the corresponding port. The latch must be fully engaged in the corresponding port for the CFP2 transceiver to function properly. Failing to do so can result in loss of connection.

To verify that the CFP2 transceiver module is inserted properly, give a gentle pull by grasping the sides of the module. The module should sit tightly.

LEDs	<p>OK/FAIL LED, one bicolor:</p> <ul style="list-style-type: none">• Off—MIC is powered off.• Green—MIC is initialized and online, functioning normally.• Amber—MIC is coming online, or is in fault state. <p>LINK LED, one bicolor per port:</p> <ul style="list-style-type: none">• Off—Port is offline.• Solid green—Link is up.• Red—Port failure is detected. <p>NOTE: The port is labeled Port 0.</p>
Alarms, Errors, and Events	<p>NOTE: For OTN alarms, see Table 67 on page 230.</p> <p>Chassis and MIC:</p> <ul style="list-style-type: none">• MIC (FRU) inserted or removed• MIC (FRU) Administrative State: In Service, Out Of Service• MIC (FRU) Operational State: Unequipped, Init, Normal, Mismatch, Fault, Upgrade• Mismatch equipment• Temperature alarm <p>Port (interface):</p> <ul style="list-style-type: none">• Interface Administrative State: In Service, Out Of Service, Service MA, Out of Service MA• Interface Operational State: Init, Normal, Fault, Degraded <p>Optical channel transport unit (OTU) TCAs:</p> <ul style="list-style-type: none">• OTU-TCA-BBE—15-minute background block error TCA• OTU-TCA-ES—15-minute far-end errored seconds TCA• OTU-TCA-SES—15-minute severely errored seconds TCA• OTU-TCA-UAS—15-minute unavailable seconds TCA <p>Optical channel data unit (ODU) TCAs:</p> <ul style="list-style-type: none">• ODU-TCA-BBE—15-minute background block error TCA• ODU-TCA-ES—15-minute far-end errored seconds TCA• ODU-TCA-SES—15-minute severely errored seconds TCA• ODU-TCA-UAS—15-minute unavailable seconds TCA <p>TIP: You can view OTU and ODU TCAs by using the show interfaces transport pm otn operational-mode CLI command.</p>

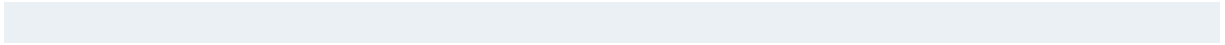

NOTE: If you insert an invalid CFP module, the CLI displays **unsupported module** and a syslog message is generated.

Optics-related status:

- Module temperature
- Module voltage
- Module temperature alarm:
 - High alarm
 - Low alarm
 - High warning
 - Low warning
- Module voltage alarm:
 - High alarm
 - Low alarm
 - High warning
 - Low warning
- Module not ready alarm
- Module low power alarm
- Module initialization incomplete alarm
- Module fault alarm
- TX laser disabled alarm
- RX loss of signal alarm
- Modem lock state
- TX output power:
 - Current TX output power
 - Minimum over PM interval
 - Maximum over PM interval
 - Average over PM interval
- TX power alarm:
 - High alarm
 - Low alarm
 - High warning
 - Low warning
- RX input power (signal)
- RX input power (total):
 - Current RX input power (total)
 - Minimum over PM interval
 - Maximum over PM interval
 - Average over PM interval
- RX power alarm:
 - High alarm
 - Low alarm
 - High warning
 - Low warning
- RX loss of signal alarm
- Wavelength unlocked alarm

TIP: You can view optics-related status by using the **show interfaces transport pm optics** and **show interfaces diagnostics optics** operational-mode CLI commands.

Network lane receive-related status:

- Chromatic dispersion:
 - Current chromatic dispersion
 - Minimum over PM interval
 - Maximum over PM interval
 - Average over PM interval
- Differential group delay:
 - Current differential group delay
 - Minimum over PM interval
 - Maximum over PM interval
 - Average over PM interval
- Q²-factor:
 - Current Q²-factor
 - Minimum over PM interval
 - Maximum over PM interval
 - Average over PM interval
- Carrier frequency offset
 - Current carrier frequency offset
 - Minimum over PM interval
 - Maximum over PM interval
 - Average over PM interval
- Signal-to-noise ratio (SNR)
 - Current SNR
 - Minimum over PM interval
 - Maximum over PM interval
 - Average over PM interval

TIP: You can view network lane receive-related status by using the **show interfaces transport pm optics** operational-mode CLI command.

FEC statistics:

- Corrected Errors—the number of bits received that were in error, but corrected.
- Uncorrected Words—the number of FEC codewords received that were uncorrectable.
- Corrected Error Ratio—the number of corrected bits divided by the number of bits received

TIP: You can view FEC statistics by using the **show interfaces interface-name extensive** operational-mode CLI command.

Table 67 on page 230 describes the OTN alarms and defects that can occur on the MIC and the link status when the alarm or defect occurs.



TIP: You can view OTN alarms and defects by using the **show interfaces interface-name extensive** operational-mode CLI command.

Table 67: OTN Alarms and Defects

Category	Alarm	Description	Link Status
OTN	LOS	Loss of signal	Link down
	LOF	Loss of frame	Link down
	LOM	Loss of multiframe	Link down
OTN FEC	FEC Degrade (OTU-FEC-DEG)	Forward error correction degraded	Link down if signal degrade or backward FRR thresholds are met
	FEC Excessive (OTU-FEC-EXE)	There are uncorrected words and there are errors in the frame header	Possible link down
OTN OTU	OTU-AIS	Alarm indication signal or all ones signal	Link down
	OTU-BDI	Backward defect identification	Link down
	OTU-IAE	Incoming alignment error	Warning
	OTU-TTIM	Destination access point identifier (DAPI), source access point identifier (SAPI), or both mismatch from expected to received	Can cause the link to be down if otu-ttim-act-enable is configured at the [edit interfaces <i>interface-name</i> otn-options] hierarchy level
	OTU-BIAE	Backward incoming alignment error	Warning
	OTU-TSF	OTU trail signal fail	Warning
	OTU-SSF	OTU server signal fail	Warning

Table 67: OTN Alarms and Defects (*continued*)

Category	Alarm	Description	Link Status
OTN ODU	ODU-AIS	Alarm indication signal or all ones signal	Link down
	ODU-OCI	Open connection error	Link down
	ODU-LCK	ODU lock triggers for path monitoring and TCM levels 1 through 6	Link down
	ODU-BDI	Backward defect indication	Link down
	ODU-TTIM	DAPI or SAPI mismatch from expected to received	Can cause the link to be down if <code>odu-ttim-act-enable</code> is configured at the <code>[edit interfaces interface-name otn-options]</code> hierarchy level
	ODU-IAE	Incoming alignment error	Warning
	ODU-LTC	Loss of tandem connection	Warning
	ODU-CSF	Client signal failure	Warning
	ODU-TSF	Trail signal fail	Warning
	ODU-SSF	Server signal fail	Warning
	ODU-PTIM	Payload type mismatch	Link down

Related Documentation

- [100-Gigabit DWDM OTN CFP2-ACO Optical Interface Specifications on page 72](#)
- [MX Series MIC Overview on page 17](#)
- [Configuring OTN Interfaces on MIC3-100G-DWDM MIC](#)
- [Upgrading Firmware on the 100-Gigabit DWDM OTN MIC \(MIC3-100G-DWDM\)](#)
- *show interfaces extensive*
- *show interfaces transport pm*
- *show interfaces diagnostics optics (Gigabit Ethernet, 10-Gigabit Ethernet, 40-Gigabit Ethernet, 100-Gigabit Ethernet, and Virtual Chassis Port)*

Channelized SONET/SDH OC3/STM1 (Multi-Rate) MICs with SFP

Figure 24: 4-Port Channelized SONET/SDH OC3/STM1 (Multi-Rate) MIC with SFP

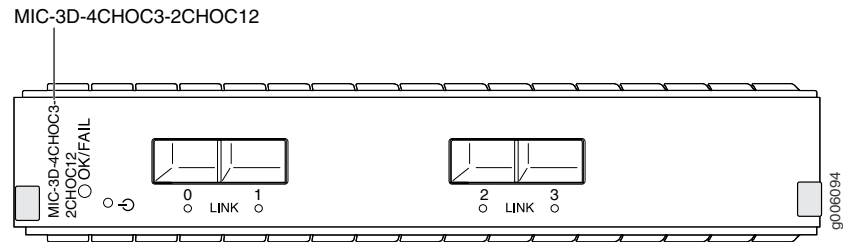
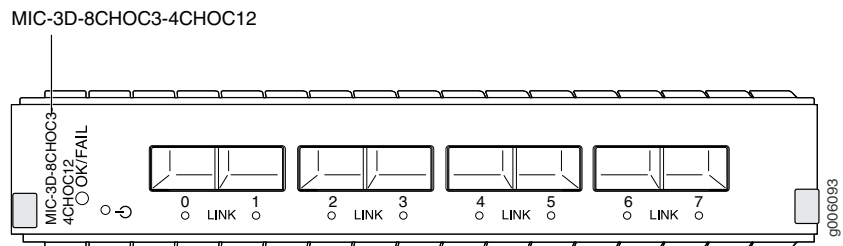

Figure 25: 8-Port Channelized SONET/SDH OC3/STM1 (Multi-Rate) MIC with SFP



Software release

- Junos OS Release 11.4 and later

For information on which MPCs support these MICs, see [“MIC/MPC Compatibility” on page 21](#). For information on which MICs are supported on MX Series routers, see [“MICs Supported by MX Series Routers” on page 17](#).

Description

- 4-port: Rate-selectable using one of the following rates:
 - 4-port OC3/STM1
 - 2-port OC12/STM4
- 8-port: Rate-selectable using one of the following rates:
 - 8-port OC3/STM1
 - 4-port OC12/STM4
- Channelization: OC3, DS3, DS1, DS0, E3, E1. For information on channelization numbers, see *Channelized Interfaces Feature Guide for Routing Devices*.
- Power requirement:
 - 4-port: 4.56 A @ 9 V (41 W)
 - 8-port: 5.78 A @ 9 V (52 W)
- Weight:
 - 4-port: 4.4 lb (2 kg)
 - 8-port: 4.4 lb (2 kg)
- Model number:
 - 4-port: MIC-3D-4CHOC3-2CHOC12
 - 8-port: MIC-3D-8CHOC3-4CHOC12

- Hardware features
- The ports are labeled:
 - 4-port: 0-3
 - 8-port: 0-7

- Software features
- Maximum transmission units (MTUs) of up to 9192 bytes
 - Per-port SONET/SDH framing
 - Local and remote loopback on each port
 - Optical diagnostics and monitoring
 - Clocking options: internal or external/loop mode
 - Encapsulations:
 - MPLS fast reroute
 - MPLS CCC (circuit cross-connection)
 - MPLS TCC (translational cross-connection)
 - Cisco High-Level Data Link Control (cHDLC)
 - Cisco HDLC CCC
 - Cisco HDLC TCC
 - Point-to-Point Protocol (PPP)
 - PPP for CCC
 - PPP for TCC
 - Flexible Frame Relay
 - Frame Relay
 - Frame Relay for CCC
 - Frame Relay for TCC
 - PPP over Frame Relay
 - Multilink-based protocols (Junos OS Release 12.1 and later):
 - Multilink Point-to-Point Protocol (MLPPP)
 - Multiclass MLPPP
 - Multilink Frame Relay (MLFR) end-to-end (FRF.15)
 - Multilink Frame Relay (MLFR) UNI NNI (FRF.16, also referred to as MFR)
 - Compressed Real-Time Transport Protocol (CRTP)

NOTE: When you configure multilink services on a MIC in an MX Series router, ensure that a Multiservices DPC is present in the same router.

NOTE: Ethernet over Frame Relay is not supported.

- Cables and connectors
- Duplex LC/PC connector (Rx and Tx)
 - SONET/SDH OC3/STM1 small form-factor pluggable (SFP) transceivers:
 - Multimode (model number: SFP-OC3-SR)
 - Intermediate reach (IR-1) (model number: SFP-OC3-IR)
 - Long reach (LR-1) (model number: SFP-OC3-LR)
 Optical interface specifications—see [“SONET/SDH OC3/STM1 Optical Interface Specifications” on page 76](#)
 - SONET/SDH OC12/STM4 small form-factor pluggable (SFP) transceivers:
 - Short reach (model number: SFP-OC12-SR)
 - Intermediate reach (IR-1) (model number: SFP-OC12-IR)
 - Long reach (LR-1) (model number: SFP-OC12-LR)
 - Long reach (LR-2) (model number: SFP-OC12-LR2)
 Optical interface specifications—see [“SONET/SDH OC12/STM4 Optical Interface Specifications” on page 78](#)

- LEDs
- OK/FAIL LED, one bicolor:**
- Green—MIC is functioning normally
 - Red—MIC has failed
- LINK LED, one green per port:**
- Off—Not enabled
 - Green—Online with no alarms or failures
 - Yellow—Online with alarms for remote failures
 - Red—Active with a local alarm; router has detected a failure

- Alarms, errors, and events
- SONET alarms:
- Loss of light (LOL)
 - Loss of signal (LOS)
 - Loss of frame (LOF)
 - Phase lock loop (PLL)
 - Severely errored frame (SEF)
 - Alarm indicator signal–line (AIS-L)
 - Alarm indicator signal–path (AIS-P)
 - Remote defect indicator–line (RDI-L)
 - Remote defect indicator–path (RDI-P)
 - Loss of pointer–path (LOP-P)
 - Bit error rate–signal degrade (BERR-SD)
 - Bit error rate–signal fail (BERR-SF)
 - Payload label mismatch–Path (PLM-P)
 - Unequipped–path (UNEQ-P)
 - Remote error indicator–path (REI-P)
 - Alarm indicator signal–virtual container (V-AIS)
 - Loss of pointer–virtual container (V-LOP)
 - Remote defect indicator–virtual container (V-RDI)
 - Unequipped–virtual container (V-UNEQ)
 - Mismatch–virtual container (V-MIS)

SDH alarms:

- Loss of light (LOL)
- Phase lock loop (PLL)
- Loss of frame (LOF)
- Loss of signal (LOS)
- Severely errored frame (SEF)
- Multiplex-section alarm indicator signal (MS-AIS)
- Higher order path—alarm indication signal (HP-AIS)
- Loss of pointer (LOP)
- Bit error rate—signal degrade (BER-SD)
- Bit error rate—signal fail (BER-SF)
- Multiplex section—far end receive failure (MS-FERF)
- Higher order path—far-end receive failure (HP-FERF)
- Higher order path—payload label mismatch (HP-PLM)
- Remote error indicator (REI)
- Unequipped (UNEQ)
- Tributary unit—alarm indicator signal (TU-AIS)
- Tributary unit—loss of pointer (TU-LOP)
- Tributary unit—remote defect indicator (TU-RDI)
- Tributary unit—unequipped (TU-UNEQ)
- Tributary unit—mismatch (TU-MIS)

DS3 alarms:

- Alarm indication signal (AIS)
- Loss of frame (LOF)
- Loss of signal seconds (LOS)
- Phase lock loop (PLL)

DS3 error detection:

- C-bit code violations (CCV)
- C-bit errored seconds (CES)
- C-bit severely errored seconds (CSES)
- CRC errors
- Excessive zeros (EXZ)
- Far-end block error (FEBE)
- Far-end receive failure (FERF)
- Line errored seconds (LES)
- Parity bit (P-bit) code violations (PCV)
- Parity bit (P-bit) errored seconds (PES)
- Parity bit (P-bit) severely errored framing seconds (PSES)
- Severely errored framing seconds (SEFS)
- Unavailable seconds (UAS)

**Related
Documentation**

- [MX Series MIC Overview on page 17](#)

Channelized OC3/STM1 (Multi-Rate) Circuit Emulation MIC with SFP

Figure 26: Channelized OC3/STM1 (Multi-Rate) Circuit Emulation MIC with SFP

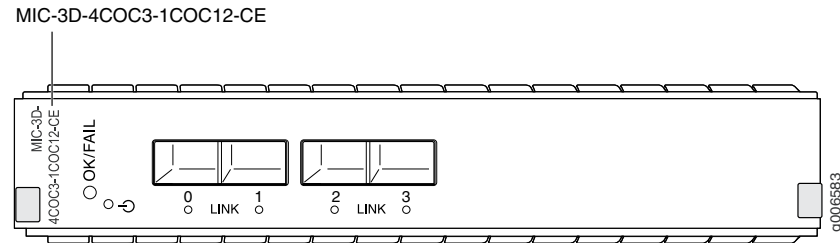

Software release	<ul style="list-style-type: none"> Junos OS Release 12.2 and later <p>For information on which MPCs support this MIC, see "MIC/MPC Compatibility" on page 21. For information on which MICs are supported on MX Series routers, see "MICs Supported by MX Series Routers" on page 17.</p>
Description	<ul style="list-style-type: none"> Four OC3/STM1 ports Rate-selectable using one of the following rates: <ul style="list-style-type: none"> 4-port OC3/STM1 1-port OC12/STM4 One channelized OC12/STM4 port (down to DS0) SONET or SDH is configurable on a MIC level OC3 channelization: <ul style="list-style-type: none"> 4 OC3 channel 336 DS1 channels 2016 DS0 channels (combination of nxDS0) SDH channelization: <ul style="list-style-type: none"> 4 STM1 channel 252 E1 channels 2016 DS0 channels (combination of nxDS0) Power requirement: 2.83 A @ 12 V (33.96 W) Weight: 1.63 lb (0.74 kg) Model number: MIC-3D-4COC3-1COC12-CE
Hardware features	<ul style="list-style-type: none"> Ports are numbered 0 through 3

- Software features
- Per-MIC SONET/SDH framing
 - Internal and loop clocking
 - Encapsulations:
 - Pseudo Wire Emulation Edge-to-Edge (PWE3) Architecture (RFC 3985)
 - Requirements for Pseudo-Wire Emulation Edge-to-Edge (PWE3) (RFC 3916)
 - Structure-Agnostic Time Division Multiplexing (TDM) over Packet (SAToP) (RFC 4553)
 - Structure-Aware Time Division Multiplexed (TDM) Circuit Emulation Service over Packet Switched Network (CESoPSN) (RFC 5086)
 - Pseudowire Emulation Edge-to-Edge (PWE3) Control Word for Use over an MPLS PSN (RFC 4385)
 - L2 Network Interconnections (protocol stitching):
 - TDM LDP PWs to BGP L2VPN—see *Using the Layer 2 Interworking Interface to Interconnect a Layer 2 Circuit to a Layer 2 VPN* for more information. Note that stitching CESoPSN PW to BGP L2VPN is not supported.
 - Unified in-service software upgrade (unified ISSU)

Interfaces

Syntax: *mediatype-fpc/pic/port* where:

- mediatype: coc3, coc12, cstm1, cstm4, or ds
- fpc: Slot in the router where the MPC is installed
- pic: 0 when installed in MIC slot 0 or 2 when installed in MIC slot 1
- port: 0 through 3

For example, *cstm4-1/2/0* is the channelized STM4 interface for port 0 on the MIC installed in MIC slot 1 on an MPC installed in slot 1.

- Cables and connectors
- Duplex LC/PC connector (Rx and Tx)
 - SONET/SDH OC3/STM1 small form-factor pluggable (SFP) transceivers:
 - Multimode (model number: SFP-OC3-SR)
 - Intermediate reach (IR-1) (model number: SFP-OC3-IR)
 - Long reach (LR-1) (model number: SFP-OC3-LR)

Optical interface specifications—see [“SONET/SDH OC3/STM1 Optical Interface Specifications” on page 76](#)
 - SONET/SDH OC12/STM4 small form-factor pluggable (SFP) transceivers:
 - Short reach (model number: SFP-OC12-SR)
 - Intermediate reach (IR-1) (model number: SFP-OC12-IR)
 - Long reach (LR-1) (model number: SFP-OC12-LR)

Optical interface specifications—see [“SONET/SDH OC12/STM4 Optical Interface Specifications” on page 78](#)

NOTE: To extend the life of the laser, when a MIC is not being actively used with any valid links, take the MIC offline until you are ready to establish a link to another device. For information about taking a MIC offline, see the `request chassis pic offline` command in the *Junos OS System Basics and Services Command Reference*.

LEDs**OK/FAIL LED**, one bicolor:

- Green—MIC is functioning normally
- Red—MIC has failed

LINK LED, one tricolor per port:

- Off—Not enabled
- Green—Online with no alarms or failures
- Yellow—Online with alarms for remote failures
- Red—Active with a local alarm; router has detected a failure

Alarms, errors, and events

Structure-agnostic alarms for T1 and E1 interface:

- Alarm indication signal (AIS)
- Loss of signal (LOS)
- Line code violation (LCV)
- Errored seconds (ES)
- Line-errored seconds (LES)
- Severely errored seconds (SES)
- Unavailable errored seconds (UAS)

Structure aware alarms for T1 and E1 interface:

- Severely errored frame (SEF)
- Block error event (BEE)
- Loss of frame (LOF)
- Yellow alarm (remote alarm indication RAI)
- Path code violation (PCV)
- Severely errored frame seconds (SEFS)
- Bursty errored seconds (BES)

Related Documentation

- [MX Series MIC Overview on page 17](#)
- *Using the Layer 2 Interworking Interface to Interconnect a Layer 2 Circuit to a Layer 2 VPN*

Channelized OC3/STM1 (Multi-Rate) Circuit Emulation MIC with SFP (H)

Figure 27: Channelized OC3/STM1 (Multi-Rate) Circuit Emulation MIC with SFP (H)

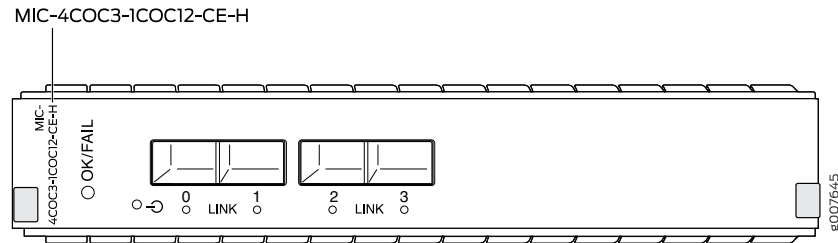

Software release

- Junos OS Release 13.2R2 and later

For information on which MPCs support this MIC, see [“MIC/MPC Compatibility” on page 21](#). For information on which MICs are supported on MX Series routers, see [“MICs Supported by MX Series Routers” on page 17](#).

Description

- Four OC3/STM1 ports
- Rate-selectable using one of the following rates:
 - 4-port OC3/STM1
 - 1-port OC12/STM4
- One channelized OC12/STM4 port (down to DS0)
- SONET or SDH is configurable on a MIC level
- SONET channelization:
 - 4 OC3 channel
 - 336 DS1 channels
 - 2016 DS0 channels (combination of nxDS0)
- SDH channelization:
 - 4 STM1 channel
 - 252 E1 channels
 - 2016 DS0 channels (combination of nxDS0)
- Power requirement: 2.83 A @ 12 V (33.96 W)
- Weight: 1.63 lb (0.74 kg)
- Model number: MIC-4COC3-1COC12-CE-H

Hardware features

- Ports are numbered 0 through 3
- Environmentally hardened for -40°F (-40°C) to 149°F (65°C) operating temperatures

Software features	<ul style="list-style-type: none"> • Per-MIC SONET/SDH framing • Internal and loop clocking • Encapsulations: <ul style="list-style-type: none"> • Pseudo Wire Emulation Edge-to-Edge (PWE3) Architecture (RFC 3985) • Requirements for Pseudo-Wire Emulation Edge-to-Edge (PWE3) (RFC 3916) • Structure-Agnostic Time Division Multiplexing (TDM) over Packet (SAToP) (RFC 4553) • Structure-Aware Time Division Multiplexed (TDM) Circuit Emulation Service over Packet Switched Network (CESoPSN) (RFC 5086) • Pseudowire Emulation Edge-to-Edge (PWE3) Control Word for Use over an MPLS PSN (RFC 4385)
-------------------	--

Interfaces	<p>Syntax: <i>mediatype-fpc/pic/port</i> where:</p> <ul style="list-style-type: none"> • mediatype: coc3, coc12, cstm1, cstm4, or ds • fpc: Slot in the router where the MPC is installed • pic: 0 when installed in MIC slot 0 or 2 when installed in MIC slot 1 • port: 0 through 3 <p>For example, cstm4-1/2/0 is the channelized STM4 interface for port 0 on the MIC installed in MIC slot 1 on an MPC installed in slot 1.</p>
------------	--

Cables and connectors	<ul style="list-style-type: none"> • Duplex LC/PC connector (Rx and Tx) • SONET/SDH OC3/STM1 small form-factor pluggable (SFP) transceivers: <ul style="list-style-type: none"> • Multimode (model number: SFP-OC3-SR) • Intermediate reach (IR-1) (model number: SFP-OC3-IR) • Long reach (LR-1) (model number: SFP-OC3-LR) <p>Optical interface specifications—see “SONET/SDH OC3/STM1 Optical Interface Specifications” on page 76</p> • SONET/SDH OC12/STM4 small form-factor pluggable (SFP) transceivers: <ul style="list-style-type: none"> • Short reach (model number: SFP-OC12-SR) • Intermediate reach (IR-1) (model number: SFP-OC12-IR) • Long reach (LR-1) (model number: SFP-OC12-LR) <p>Optical interface specifications—see “SONET/SDH OC12/STM4 Optical Interface Specifications” on page 78</p> <p>NOTE: To extend the life of the laser, when a MIC is not being actively used with any valid links, take the MIC offline until you are ready to establish a link to another device. For information about taking a MIC offline, see the request chassis pic offline command in the <i>Junos OS System Basics and Services Command Reference</i>.</p>
-----------------------	--

LEDs	<p>OK/FAIL LED, one bicolor:</p> <ul style="list-style-type: none"> • Green—MIC is functioning normally • Red—MIC has failed <p>LINK LED, one tricolor per port:</p> <ul style="list-style-type: none"> • Off—Not enabled • Green—Online with no alarms or failures • Yellow—Online with alarms for remote failures • Red—Active with a local alarm; router has detected a failure
------	--

Alarms, errors, and events

Structure-agnostic alarms for T1 and E1 interface:

- Alarm indication signal (AIS)
- Loss of signal (LOS)
- Line code violation (LCV)
- Errored seconds (ES)
- Line-errored seconds (LES)
- Severely errored seconds (SES)
- Unavailable errored seconds (UAS)

Structure aware alarms for T1 and E1 interface:

- Severely errored frame (SEF)
- Block error event (BEE)
- Loss of frame (LOF)
- Yellow alarm (remote alarm indication RAI)
- Path code violation (PCV)
- Severely errored frame seconds (SEFS)
- Bursty errored seconds (BES)

Related Documentation

- [MX Series MIC Overview on page 17](#)

Channelized E1/T1 Circuit Emulation MIC

Figure 28: Channelized E1/T1 Circuit Emulation MIC

MIC-3D-16CHE1-T1-CE

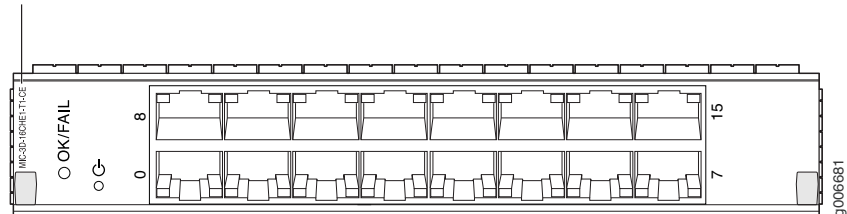

Software release

- Junos OS Release 12.3 and later

For information on which MPCs support this MIC, see [“MIC/MPC Compatibility” on page 21](#). For information on which MICs are supported on MX Series routers, see [“MICs Supported by MX Series Routers” on page 17](#).

Description	<ul style="list-style-type: none">• Sixteen E1 or T1 ports• Per-MIC E1/T1 framing• DS1 channelization per port:<ul style="list-style-type: none">• 1 DS1 channel• 24 DS0 channels• E1 channelization per port:<ul style="list-style-type: none">• 1 E1 channel• 32 DS0 channels• Internal and loop clocking• Power requirement: 2.21 A @ 12 V (26.55 W)• Weight: 1.57 lb (0.71 kg)• Model number: MIC-3D-16CHE1-T1-CE
Hardware features	<ul style="list-style-type: none">• Ports are numbered:<ul style="list-style-type: none">• Top row: 8 and 15 from left to right• Bottom row: 0 and 7 from left to right
Software features	<ul style="list-style-type: none">• Full bit error rate test (BERT)• DS1 and E1 interfaces are selectable on a per-port granularity• Per-port framing is not supported• You can configure the following framing modes using the CLI:<ul style="list-style-type: none">• T1—SF, ESF, D4/superframe, ESF (extended superframe)• E1—G704, G704—no-crc4, unframed• Local, remote, and per-port loopback diagnostics• Encapsulations:<ul style="list-style-type: none">• Pseudowire Emulation Edge to Edge (PWE3) Architecture (RFC 3985)• Requirements for Pseudowire Emulation Edge to Edge (PWE3) (RFC 3916)• Structure-Agnostic Time Division Multiplexing (TDM) over Packet (SAToP) (RFC 4553)• Structure-Aware Time Division Multiplexed (TDM) Circuit Emulation Service over Packet-Switched Network (CESoPSN) (RFC 5086)• Pseudowire Emulation Edge to Edge (PWE3) Control Word for Use over an MPLS PSN (RFC 4385)• In-service software upgrade (Unified ISSU)
Cables and connectors	<ul style="list-style-type: none">• RJ-48 connector
LEDs	<p>OK/FAIL LED, one bicolor:</p> <ul style="list-style-type: none">• Green—MIC is functioning normally.• Red—MIC has failed. <p>One tricolor per port:</p> <ul style="list-style-type: none">• Off—Not enabled.• Green—Online with no alarms or failures.• Yellow—Online with alarms for remote failures.• Red—Active with a local alarm; router has detected a failure.

Alarms, errors, and events

- Structure-agnostic alarms for T1 and E1 interface:
 - Alarm indication signal (AIS)
 - Loss of signal (LOS)
- Structure-aware alarms for T1 and E1 interface:
 - Loss of signal (LOS)
 - Alarm indication signal (AIS)
 - Loss of frame (LOF)
 - Remote alarm indication signal (RAIS)
- Structure-agnostic error detection for T1 and E1 interface:
 - Errored seconds (ES)
 - Line code violation (LCV)
 - Line errored seconds (LES)
 - Severely errored seconds (SES)
 - Unavailable seconds (UAS)
 - Loss of signal seconds (LOSS)
- Structure-aware error detection for T1 and E1 interface:
 - Severely errored frame (SEF)
 - Block error event (BEE)
 - Line code violation (LCV)
 - Path code violation (PCV)
 - Line errored seconds (LES)
 - Errored seconds (ES)
 - Severely errored seconds (SES)
 - Severely errored frame seconds (SEFS)
 - Bursty errored seconds (BES)
 - Unavailable seconds (UAS)
 - Loss of signal seconds (LOSS)
 - Loss of framing seconds (LOFS)
 - Far-end block error (FEBE) (E1 only)
 - CRC errors (E1 only)

Related Documentation

- [MX Series MIC Overview on page 17](#)

Channelized E1/T1 Circuit Emulation MIC (H)

Figure 29: Channelized E1/T1 Circuit Emulation MIC (H)

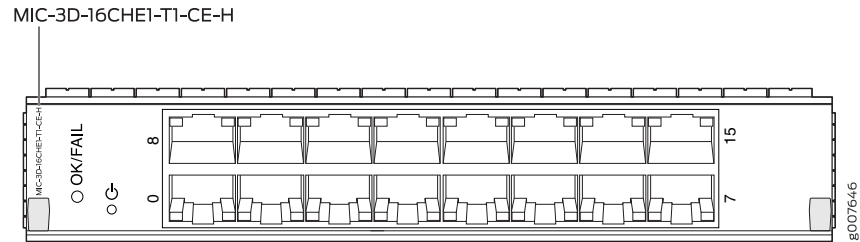

Software release

- Junos OS Release 13.2R2 and later

For information on which MPCs support this MIC, see “MIC/MPC Compatibility” on page 21. For information on which MICs are supported on MX Series routers, see “MICs Supported by MX Series Routers” on page 17.

Description

- Sixteen E1 or T1 ports
- Per-MIC E1/T1 framing
- DS1 channelization per port:
 - 1 DS1 channel
 - 24 DS0 channels
- E1 channelization per port:
 - 1 E1 channel
 - 32 DS0 channels
- Internal and loop clocking
- Power requirement: 2.21 A @ 12 V (26.55 W)
- Weight: 1.57 lb (0.71 kg)
- Model number: MIC-3D-16CHE1-T1-CE-H

Hardware features

- Ports are numbered:
 - Top row: 8 and 15 from left to right
 - Bottom row: 0 and 7 from left to right
- Environmentally hardened for -40°F (-40°C) to 149°F (65°C) operating temperatures

Software features	<ul style="list-style-type: none"> • Full bit error rate test (BERT) • DS1 and E1 interfaces are selectable on a per-port granularity • Per-port framing is not supported • You can configure the following framing modes using the CLI: <ul style="list-style-type: none"> • T1—SF, ESF, D4/superframe, ESF (extended superframe) • E1—G704, G704—no-crc4, unframed • Local, remote, and per-port loopback diagnostics • Encapsulations: <ul style="list-style-type: none"> • Pseudowire Emulation Edge to Edge (PWE3) Architecture (RFC 3985) • Requirements for Pseudowire Emulation Edge to Edge (PWE3) (RFC 3916) • Structure-Agnostic Time Division Multiplexing (TDM) over Packet (SAToP) (RFC 4553) • Structure-Aware Time Division Multiplexed (TDM) Circuit Emulation Service over Packet-Switched Network (CESoPSN) (RFC 5086) • Pseudowire Emulation Edge to Edge (PWE3) Control Word for Use over an MPLS PSN (RFC 4385)
-------------------	--

Interfaces	<p>Syntax: <i>media-type-fpc/pic/port</i> where:</p> <ul style="list-style-type: none"> • media-type: ct1, ds, t1, or e1 • fpc: Slot in the router where the MPC is installed • pic: 0 when installed in MIC slot 0 or 2 when installed in MIC slot 1 • port: 0 through 15 <p>For example, t1-2/2/0 is the T1 interface for port 0 on the MIC installed in MIC slot 1 on an MPC installed in slot 2.</p>
------------	--

Cables and connectors	<ul style="list-style-type: none"> • RJ-48 connector
-----------------------	---

LEDs	<p>OK/FAIL LED, one bicolor:</p> <ul style="list-style-type: none"> • Green—MIC is functioning normally. • Red—MIC has failed. <p>One tricolor per port:</p> <ul style="list-style-type: none"> • Off—Not enabled. • Green—Online with no alarms or failures. • Yellow—Online with alarms for remote failures. • Red—Active with a local alarm; router has detected a failure.
------	---

Alarms, errors, and events

- Structure-agnostic alarms for T1 and E1 interface:
 - Alarm indication signal (AIS)
 - Loss of signal (LOS)
- Structure-aware alarms for T1 and E1 interface:
 - Loss of signal (LOS)
 - Alarm indication signal (AIS)
 - Loss of frame (LOF)
 - Remote alarm indication signal (RAIS)
- Structure-agnostic error detection for T1 and E1 interface:
 - Errored seconds (ES)
 - Line code violation (LCV)
 - Line errored seconds (LES)
 - Severely errored seconds (SES)
 - Unavailable seconds (UAS)
 - Loss of signal seconds (LOSS)
- Structure-aware error detection for T1 and E1 interface:
 - Severely errored frame (SEF)
 - Block error event (BEE)
 - Line code violation (LCV)
 - Path code violation (PCV)
 - Line errored seconds (LES)
 - Errored seconds (ES)
 - Severely errored seconds (SES)
 - Severely errored frame seconds (SEFS)
 - Bursty errored seconds (BES)
 - Unavailable seconds (UAS)
 - Loss of signal seconds (LOSS)
 - Loss of framing seconds (LOFS)
 - Far-end block error (FEBE) (E1 only)
 - CRC errors (E1 only)

Related Documentation

- [MX Series MIC Overview on page 17](#)

Tri-Rate MIC

Figure 30: 40-Port Tri-Rate MIC

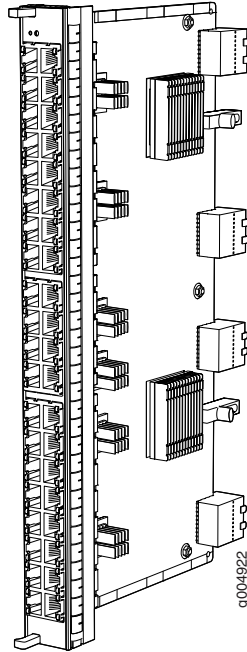

Software release	<ul style="list-style-type: none"> Junos 10.2 and later <p>For information on which MPCs support this MIC, see “MIC/MPC Compatibility” on page 21. For information on which MICs are supported on MX Series routers, see “MICs Supported by MX Series Routers” on page 17.</p>
Description	<ul style="list-style-type: none"> 40 autonegotiating 10BASE-T, 100BASE-TX, or 1000BASE-T Megabit Ethernet ports Power requirement: 0.85 A @ 48 V (41 W) Weight: 1.9 lb (0.9 kg) Model number: MIC-3D-40GE-TX Name in the CLI: 3D 40GE TX
Hardware features	<ul style="list-style-type: none"> Dual-wide MIC that installs into 2 slots. <p>For information on how to install dual-wide MICs, see the <i>Installing Dual-Wide MIC</i> topic in the respective <i>MX Series Router Hardware Guide</i>.</p> High-performance throughput on each port at speeds of 10 Mbps, 100 Mbps, or 1000 Mbps Up to 40-Gbps of full-duplex traffic Autonegotiation between Gigabit Ethernet circuit partners Maximum transmission units (MTUs) of up to 9192 bytes

Software features	<ul style="list-style-type: none">• Virtual Router Redundancy Protocol (VRRP) support• IEEE 802.1Q virtual LANs (VLANs) support• Remote monitoring (RMON) EtherStats• Source MAC learning• MAC accounting and policing—Dynamic local address learning of source MAC addresses• Flexible Ethernet encapsulation• Multiple tag protocol identifiers (TPID)
Interfaces	<p>Syntax: <i>ge-fpc/pic/port</i> where:</p> <ul style="list-style-type: none">• fpc: Slot in the router where the MPC is installed.• pic: The logical PIC number on the MIC numbered 0, 1, 2, and 3.• port: 0 through 9 <p>For example, <i>ge-2/3/0</i> is the interface for port 0 in PIC 3 on the MPC installed in slot 2.</p> <p>Figure 14 on page 205, Figure 32 on page 250, and Figure 33 on page 250 illustrate the port numbering for the Tri-Rate MIC installed in the MX960, MX480, and MX240, respectively.</p>
Cables and connectors	<ul style="list-style-type: none">• Connector: Four-pair, Category 5 shielded twisted-pair connectivity through an RJ-45 connector• Pinout: MDI, MDI crossover• Maximum distance: 328 ft (100 m) <p>CAUTION: Do not use RJ-45 cables with strain-relief boots exceeding 1.5 mm from the bottom of the connector. Cable boots that exceed this measurement can damage the port.</p>
LEDs	<p>OK/fail LED, one bicolor:</p> <ul style="list-style-type: none">• Green—MIC is functioning normally.• Red—MIC has failed. <p>Link LED, one green per port:</p> <ul style="list-style-type: none">• Off—No link.• On steadily—Link is up.

[Figure 14 on page 205](#), [Figure 32 on page 250](#), and [Figure 33 on page 250](#) illustrate the port numbering for the Tri-Rate MIC installed in the MX960, MX480, and MX240, respectively.

Figure 31: Port Numbering for the Tri-Rate MIC (MX960)

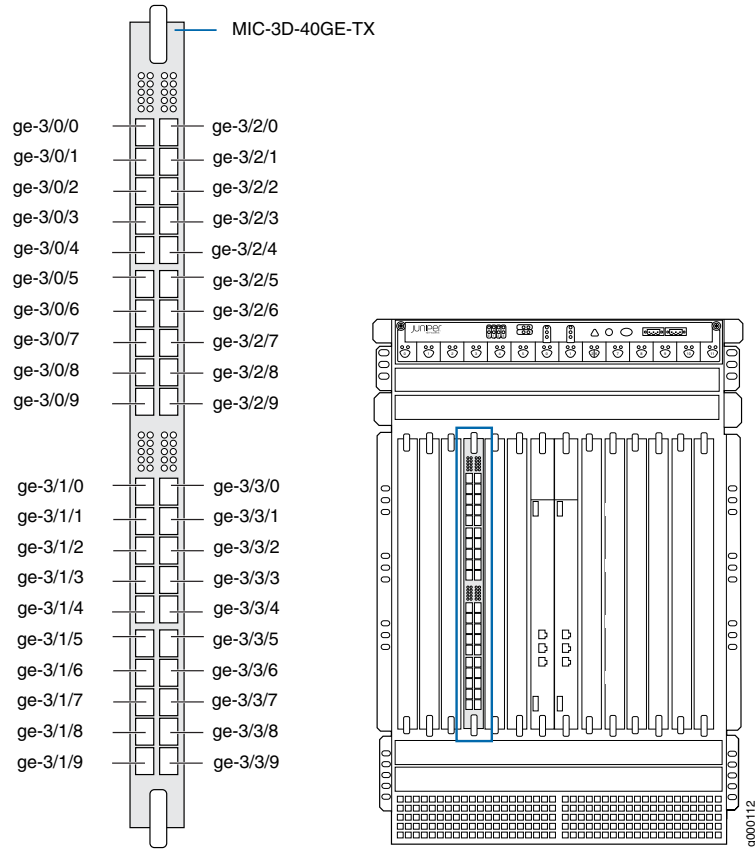

Figure 32: Port Numbering for the Tri-Rate MIC (MX480)

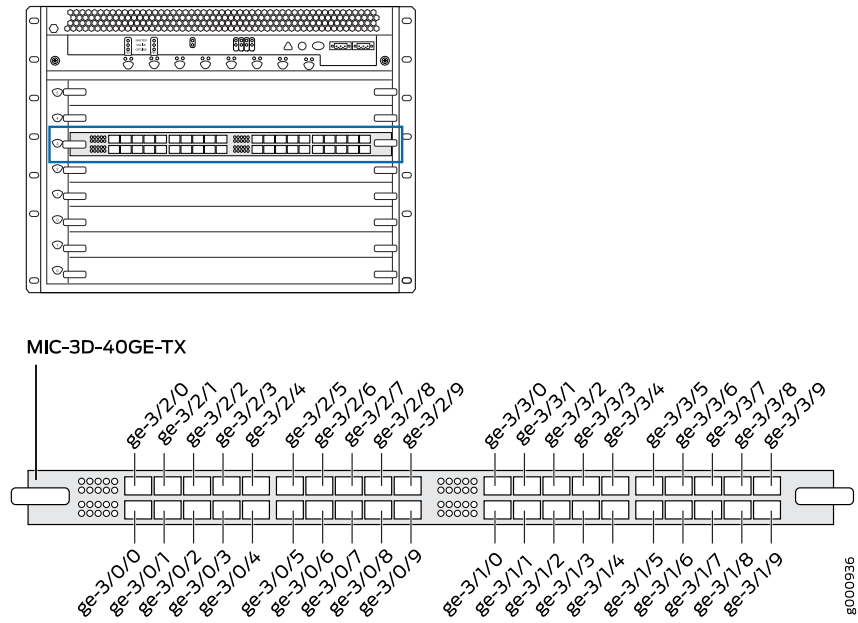
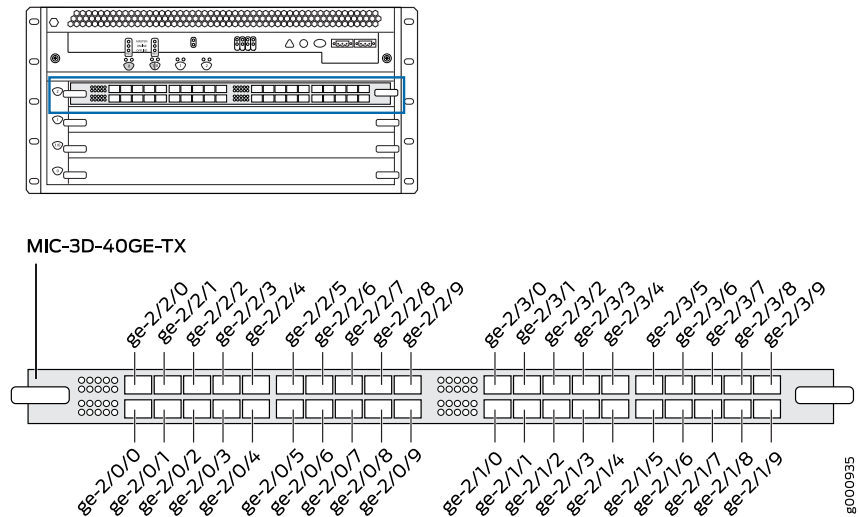

Figure 33: Port Numbering for the Tri-Rate MIC (MX240)



Related Documentation • [MX Series MIC Overview on page 17](#)

MIC MRATE

Figure 34: 12-Port Multi-Rate MIC with QSFP+

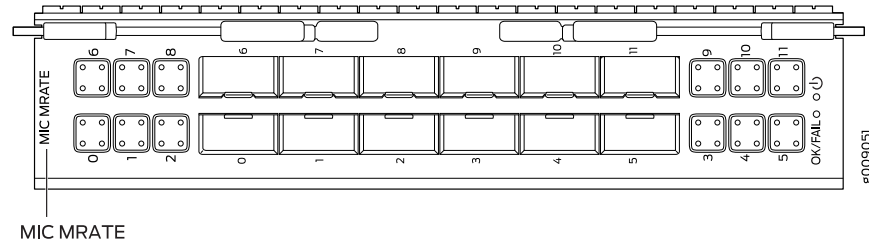

Software release	<ul style="list-style-type: none"> Junos OS Release 15.1F5 with Junos Continuity Junos OS release 16.1R1 and later <p>For information about which MPCs support this MIC, see “MIC/MPC Compatibility” on page 21. For information about which MICs are supported on MX Series routers, see “MICs Supported by MX Series Routers” on page 17.</p>
Description	<ul style="list-style-type: none"> Twelve Gigabit Ethernet ports that support quad small form-factor pluggable plus (QSFP+) transceivers Power requirement; <ul style="list-style-type: none"> When installed into MPC8E: 1.250 A @ 48 V (60 W) When installed into MPC9E, or into MPC8E operating in 1.6 Tbps upgrade mode (licensed feature): 1.771 A @ 48 V (85 W) Weight: 3.9 lb (1.77 kg) Model number: MIC-MRATE Name in the CLI: MRATE-12xQSFP+XGE-XLGE-CGE
Hardware features	<ul style="list-style-type: none"> Twelve Gigabit Ethernet QSFP+ ports, each of which can be configured as a 40-Gigabit Ethernet port or as four 10-Gigabit Ethernet ports by using a breakout cable. Eight out of the twelve ports can be configured as 100-Gigabit Ethernet ports. Port numbers 0 through 3, and 6 through 9 are the eight 100-Gigabit Ethernet ports. When used in MX2K-MP8CE: <ul style="list-style-type: none"> 4 ports out of the total 12 support 100-Gigabit Ethernet speed Maximum aggregate port capacity across ports 0 through 5 should not exceed 240 Gbps Maximum aggregate port capacity across ports 6 through 11 should not exceed 240 Gbps When used in MX2K-MPC9E: <ul style="list-style-type: none"> 8 ports out of the total 12 support 100-Gigabit Ethernet speed Maximum aggregate port capacity across ports 0 through 5 should not exceed 400 Gbps Maximum aggregate port capacity across ports 6 through 11 should not exceed 400 Gbps The ports are numbered 0 through 11.
Software features	<ul style="list-style-type: none"> Supports rate selectability at the port level. By default, the ports are configured as 10-Gigabit Ethernet ports. Supports remote port identification.

- Cables and connectors
- Fiber-optic 10-gigabit QSFP+ transceiver
 - 4x duplex LC breakout cable—To interface with an SFP+ transceiver at the other end. A breakout cable consists of a QSFP+ transceiver on one end (that connects to the router) and four SFP+ transceivers on the other end.
 - 10GBASE-L (model number: QSFPP-4X10GE-LR)
Connector: Female receptacle, MPO
 - 10GBASE-S (model number: QSFPP-4X10GE-SR)
Connector: Female receptacle, MPO
 - Optical interface specifications—see [“10-Gigabit Ethernet 10GBASE Optical Interface Specifications” on page 54.](#)
 - Fiber-optic 40-gigabit QSFP+ transceiver
 - 40GBASE-SR4 (model number: QSFPP-40GBASE-SR4)
Connector: Female receptacle, MPO
 - 40GBASE-LR4 (model number: QSFPP-40GBASE-LR4)
Connector: Standard Duplex LC
 - Optical interface specifications—see [“40-Gigabit Ethernet 40GBASE-R Optical Interface Specifications” on page 64.](#)
 - Fiber-optic 100-gigabit QSFP+ transceiver
 - 100GBASE-SR4 (model number: QSFPP-100GBASE-SR4)
Connector: MPO
 - 100GBASE-LR4 (model number: QSFPP-100GBASE-LR4)
Connector: Standard Duplex LC
 - Optical interface specifications—see [“100-Gigabit Ethernet 100GBASE-R Optical Interface Specifications” on page 68.](#)

LEDs

OK/FAIL LED, one bicolor:

- Steady green—MIC is functioning normally.
- Yellow—MIC has failed.

Link LED, one green per port (4 per QSFP+ cage):

- Steady green—Link is up.
- Off—Link is down or disabled.

Related Documentation

- *Junos Continuity Software (Junos OS Release 14.1R4 and Later Releases)*
- *Understanding Interface Naming Conventions for MIC-MRATE*
- *Understanding Rate Selectability*
- *Configuring Rate Selectability on MIC-MRATE to Enable Different Port Speeds*

Multiservices MIC

Figure 35: MS-MIC-16G

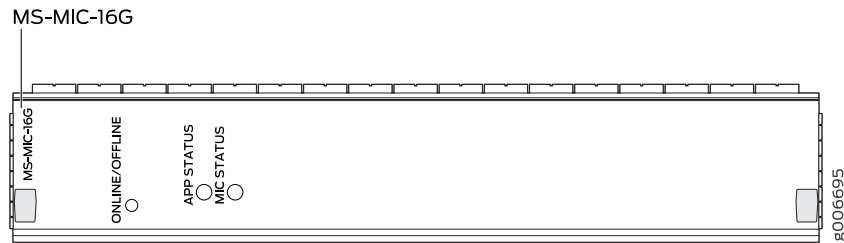

Software Release	<ul style="list-style-type: none"> Junos OS Release 13.2 and later <p>For information on which MPCs support these MICs, see “MIC/MPC Compatibility” on page 21. For information on which MICs are supported on MX Series routers, see “MICs Supported by MX Series Routers” on page 17.</p>
Description	<ul style="list-style-type: none"> Power requirement: 5 A @ 12 V (60 W) Model number: MS-MIC-16G Name in the CLI: MS-MIC-16G
Hardware Features	<ul style="list-style-type: none"> Active monitoring on up to 14 million flows MICs are hot-removable and hot-insertable. <p>NOTE: Only one Multiservices MIC is supported in each MPC.</p>
Software Features	<ul style="list-style-type: none"> Support for up to 6000 service sets Support for MTUs up to 9192 bytes. See “Protocols and Applications Supported by the MS-MIC and MS-MPC” on page 387 for information about the protocols and applications that this MIC supports.
LEDs	<p>Application activity tricolor LED, labeled APP STATUS:</p> <ul style="list-style-type: none"> Off—Application is not running. Red—Application has failed. Yellow—Application is reconfiguring. Green—Application is running. <p>MIC activity tricolor LED, labeled MIC STATUS:</p> <ul style="list-style-type: none"> Off—MIC has failed. Red—MIC has an error or failure. Yellow—MIC is transitioning online or offline. Green—MIC is functioning normally.
Related Documentation	<ul style="list-style-type: none"> MX Series MIC Overview on page 17 Protocols and Applications Supported by the MS-MIC and MS-MPC on page 387 Example: Configuring Flow Monitoring on MS-MIC and MS-MPC

SONET/SDH OC3/STM1 (Multi-Rate) MICs with SFP

Figure 36: 4-Port SONET/SDH OC3/STM1 (Multi-Rate) MIC with SFP

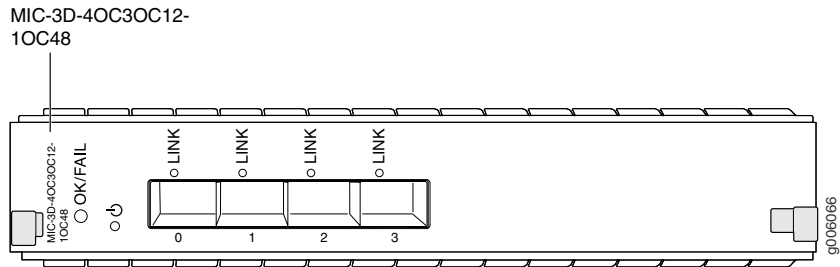
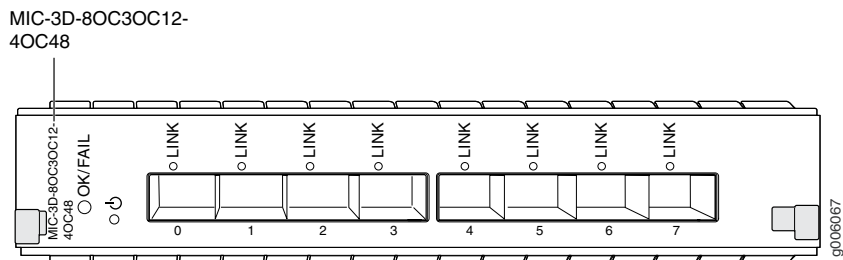

Figure 37: 8-Port SONET/SDH OC3/STM1 (Multi-Rate) MIC with SFP



Software release

- 4-port: Junos OS Release 11.2 and later
- 8-port: Junos OS Release 11.2 and later

For information on which MPCs support these MICs, see [“MIC/MPC Compatibility” on page 21](#).
 For information on which MICs are supported on MX Series routers, see [“MICs Supported by MX Series Routers” on page 17](#).

- Description
- 4-port: 4 OC3/STM1 or OC12/STM4 ports
 - Each port is rate-selectable and supports OC3, OC12, or OC48.
 - The ports can be configured to support a combination of OC3, OC12, and OC48 rates. In the combination, you can configure only one port to support OC48, whereas OC3 or OC12 can be configured on all four ports.
 - 8-port: 8 OC3/STM1 or OC12/STM4 ports
 - Each port is rate-selectable and supports OC3, OC12, or OC48.
 - The ports can be configured to support a combination of OC3, OC12, and OC48 rates. In the combination, you can configure only four ports to support OC48, whereas OC3 or OC12 can be configured on all eight ports.
 - Power requirement:
 - 4-port: 2.6 A @ 9 V (23.4 W)
 - 8-port: 3.1 A @ 9 V (27.9 W)
 - Weight:
 - 4-port: 1.27 lb (0.58 kg)
 - 8-port: 1.47 lb (0.67 kg)
 - Model number:
 - 4-port: MIC-3D-4OC3OC12-1OC48
 - 8-port: MIC-3D-8OC3OC12-4OC48

- Hardware features
- The ports are labeled:
 - 4-port: 0-3
 - 8-port: 0-7
 - Maximum transmission units (MTUs) of up to 9192 bytes

- Software features
- Per-port SONET/SDH framing
 - Local and remote loopback on each port
 - Optical diagnostics and monitoring
 - Clocking options: internal or external/loop mode.
 - Unified in-service software upgrade (unified ISSU)
 - Encapsulations:
 - Multiprotocol Label Switching (MPLS) fast reroute
 - MPLS CCC (circuit cross-connect)
 - MPLS TCC (translational cross-connect)
 - Cisco High-Level Data Link Control
 - Cisco HDLC CCC
 - Cisco HDLC TCC
 - Point-to-Point Protocol (PPP)
 - PPP for CCC
 - PPP for TCC
 - Flexible Frame Relay
 - Frame Relay
 - Frame Relay for CCC
 - Frame Relay for TCC
 - PPP over Frame Relay

NOTE: Ethernet over Frame Relay is not supported.

- Cables and connectors
- Duplex LC/PC connector (Rx and Tx)
 - SONET/SDH OC3/STM1 SFP transceivers:
 - Multimode (model number: SFP-OC3-SR)
 - Intermediate reach (IR-1) (model number: SFP-OC3-IR)
 - Long reach (LR-1) (model number: SFP-OC3-LR)
 Optical interface specifications—see [“SONET/SDH OC3/STM1 Optical Interface Specifications” on page 76](#)
 - SONET/SDH OC12/STM4 SFP transceivers:
 - Short reach (model number: SFP-OC12-SR)
 - Intermediate reach (IR-1) (model number: SFP-OC12-IR)
 - Long reach (LR-1) (model number: SFP-OC12-LR)
 - Long reach (LR-2) (model number: SFP-OC12-LR2)
 Optical interface specifications—see [“SONET/SDH OC12/STM4 Optical Interface Specifications” on page 78](#)
 - SONET/SDH OC48/STM16 small form-factor pluggable (SFP) transceivers:
 - Multimode (model number: SFP-IOC48-SR)
 - Intermediate reach (IR-1) (model number: SFP-IOC48-IR)
 - Long reach (LR-1) (model number: SFP-IOC48-LR)
 Optical interface specifications—see [“SONET/SDH OC48/STM16 Optical Interface Specifications” on page 80](#)

LEDs**OK/FAIL LED, one bicolor:**

- Green—MIC is functioning normally
- Red—MIC has failed

LINK LED, one green per port:

- Off—Not enabled
- Green—Online with no alarms or failures
- Yellow—Online with alarms for remote failures
- Red—Active with a local alarm; router has detected a failure

Alarms, errors, and events**SONET alarms:**

- Loss of light (LOL)
- Loss of signal (LOS)
- Loss of frame (LOF)
- Phase lock loop (PLL)
- Severely errored frame (SEF)
- Alarm indicator signal–line (AIS-L)
- Alarm indicator signal–path (AIS-P)
- Remote defect indicator–line (RDI-L)
- Remote defect indicator–path (RDI-P)
- Loss of pointer–path (LOP-P)
- Bit error rate–signal degrade (BERR-SD)
- Bit error rate–signal fail (BERR-SF)
- Payload label mismatch–Path (PLM-P)
- Unequipped–path (UNEQ-P)
- Remote error indicator–path (REI-P)

SDH alarms:

- Loss of light (LOL)
- Phase lock loop (PLL)
- Loss of frame (LOF)
- Loss of signal (LOS)
- Severely errored frame (SEF)
- Multiplex-section alarm indicator signal (MS-AIS)
- H Path alarm indicator signal (HP-AIS)
- Loss of pointer (LOP)
- Bit error rate–signal degrade (BER-SD)
- Bit error rate–signal fail (BER-SF)
- Multiplex section–far end receive failure (MS-FERF)
- High order path–far end receive failure (HP-FERF)
- High order path–payload label mismatch (HP-PLM)
- Remote error indicator (REI)
- Unequipped (UNEQ)

Related Documentation

- [MX Series MIC Overview on page 17](#)

SONET/SDH OC192/STM64 MIC with XFP

Figure 38: SONET/SDH OC192/STM64 MIC with XFP

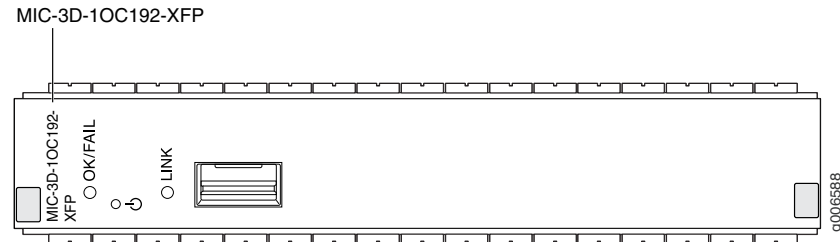

Software release

- Junos OS Release 12.2 and later

For information on which MPCs support this MIC, see [“MIC/MPC Compatibility” on page 21](#). For information on which MICs are supported on MX Series routers, see [“MICs Supported by MX Series Routers” on page 17](#).

Description

- One OC192 port
- Clear channel functionality
- Power requirement: 4.25 A @ 9 V (38.25 W)
- Weight: 1.34 lb (0.61 kg)
- Model number: MIC-3D-1OC192-XFP

Hardware features

- Maximum transmission units (MTUs) of up to 9192 bytes
- MIC bandwidth of up to 10 Gbps

Software features

- SONET/SDH framing
- Multiprotocol Label Switching (MPLS) fast reroute
- Ingress behavior aggregate (BA) classification
- Internal and loop clocking
- Encapsulations:
 - MPLS fast reroute
 - MPLS CCC (circuit cross-connection)
 - MPLS TCC (translational cross-connection)
 - Cisco High-Level Data Link Control (cHDLC)
 - Cisco HDLC CCC
 - Cisco HDLC TCC
 - Point-to-Point Protocol (PPP)
 - PPP for CCC
 - PPP for TCC
 - Flexible Frame Relay
 - Frame Relay
 - Frame Relay for CCC
 - Frame Relay for TCC
 - PPP over Frame Relay

NOTE: Ethernet over Frame Relay is not supported.

- Cables and connectors
- SONET/SDH OC192/STM64 XFP transceivers:
 - Short reach (SR-1) (model number: XFP-10G-L-OC192-SR1)
 - Intermediate reach (IR-1) (model number: XFP-10G-E-OC192-IR2)
 - Long reach (LR-1) (model number: XFP-10G-Z-OC192-LR2)
- Optical interface specifications—see “[SONET/SDH OC192/STM64 Optical Interface Specifications](#)” on page 83

NOTE: To extend the life of the laser, when a MIC is not being actively used with any valid links, take the MIC offline until you are ready to establish a link to another device. For information about taking a MIC offline, see the `request chassis pic offline` command in the [CLI Explorer](#).

LEDs

OK/FAIL LED, one bicolor:

- Green—MIC is functioning normally
- Red—MIC has failed

LINK LED, one tricolor per port:

- Off—Not enabled
- Green—Online with no alarms or failures
- Yellow—Online with alarms for remote failures
- Red—Active with a local alarm; router has detected a failure

Alarms, errors, and events**SONET alarms:**

- Loss of light (LOL)
- Phase lock loop (PLL)
- Loss of signal (LOS)
- Loss of frame (LOF)
- Severely errored frame (SEF)
- Alarm indicator signal–line (AIS-L)
- Alarm indicator signal–path (AIS-P)
- Remote defect indicator–line (RDI-L)
- Remote defect indicator–path (RDI-P)
- Loss of pointer–path (LOP-P)
- Bit error rate–signal degrade (BERR-SD)
- Bit error rate–signal fail (BERR-SF)
- Payload label mismatch–Path (PLM-P)
- Unequipped–path (UNEQ-P)
- Remote error indicator–path (REI-P)

SDH alarms:

- Loss of light (LOL)
- Phase lock loop (PLL)
- Loss of frame (LOF)
- Loss of signal (LOS)
- Severely errored frame (SEF)
- Multiplex-section alarm indicator signal (MS-AIS)
- Higher order path–alarm indication signal (HP-AIS)
- Loss of pointer (LOP)
- Bit error rate–signal degrade (BER-SD)
- Bit error rate–signal fail (BER-SF)
- Multiplex section–far end receive failure (MS-FERF)
- Higher order path–far-end receive failure (HP-FERF)
- Higher order path–payload label mismatch (HP-PLM)
- Remote error indicator (REI)
- Unequipped (UNEQ)

Related Documentation

- [MX Series MIC Overview on page 17](#)

CHAPTER 10

MX Series PIC Descriptions

- Channelized OC12/STM4 Enhanced IQ (IQE) PIC with SFP on page 262
- Channelized OC48/STM16 Enhanced IQ (IQE) PIC with SFP on page 267
- SONET/SDH OC3/STM1 (Multi-Rate) PIC with SFP on page 272
- SONET/SDH OC12/STM4 (Multi-Rate) PIC with SFP on page 275
- SONET/SDH OC48/STM16 Enhanced IQ (IQE) PIC with SFP on page 278
- SONET/SDH OC48/STM16 (Multi-Rate) PIC with SFP on page 282
- SONET/SDH OC48/STM16 PIC with SFP on page 285
- SONET/SDH OC192c/STM64 PIC on page 288
- SONET/SDH OC192c/STM64 PIC with XFP on page 291

Channelized OC12/STM4 Enhanced IQ (IQE) PIC with SFP

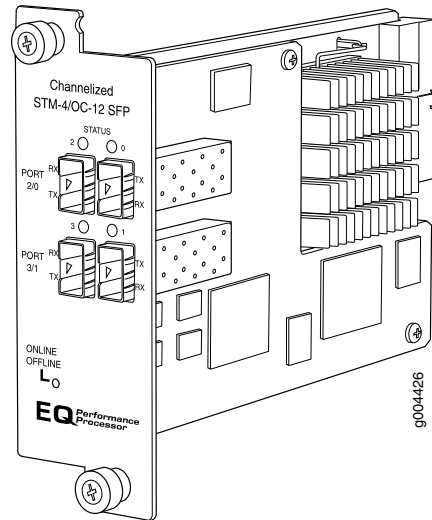

Software release	<ul style="list-style-type: none"> Junos 9.5 and later
Description	<ul style="list-style-type: none"> Four OC12/STM4 ports SONET or SDH is configurable on a per-port granularity SONET channelization: <ul style="list-style-type: none"> 4 OC12 channel 16 OC3 channels 48 DS3 channels 672 DS1 channels 975 DS0 channels SDH channelization: <ul style="list-style-type: none"> 4 STM4 channel 16 STM1 channels 48 E3 channels 504 E1 channels 975 DS0 channels Power requirement: 1.08 A @ 48V (52 W) Model Number: PB-4CHOC12-STM4-IQE-SFP
Hardware features	<ul style="list-style-type: none"> Ports are numbered: <ul style="list-style-type: none"> Top row: 2 and 0 from left to right Bottom row: 3 and 1 from left to right

Software features

- Quality of service (QoS) per channel: weighted round-robin (WRR), random early detection (RED), weighted random early detection (WRED)
- Enhanced fine-grained queuing per logical interface. See the *Class of Service Feature Guide for Routing Devices* for more information about class of service features.
- Subrate and scrambling:
 - Digital Link/Quick Eagle
 - Kentrox
 - Larscom
 - ADTRAN
 - Verilink
- Packet buffering, Layer 2 parsing
- M13/C-bit parity encoding
- DS3 far-end alarm and control (FEAC) channel support
- Local line, remote line, and remote payload loopback testing
- Simple Network Management Protocol (SNMP): OC3 MIB, DS3 MIB, T1 MIB
- Dynamic, arbitrary channel configuration
- Full bit error rate test (BERT)
- Encapsulations:
 - Circuit cross-connect (CCC)
 - Translational cross-connect (TCC)
 - Extended Frame Relay for CCC and TCC
 - Flexible Frame Relay
 - Frame Relay
 - Frame Relay for CCC
 - Frame Relay for TCC
 - Frame Relay port CCC
 - High-Level Data Link Control (HDLC)
 - HDLC framing for CCC
 - HDLC framing for TCC
 - MPLS CCC
 - MPLS TCC
 - Multilink Frame Relay (MLFR) UNI NNI (MFR FRF.16)
 - Point-to-Point Protocol (PPP)
 - PPP for CCC
 - PPP for TCC
- Encapsulations available only for DSI:
 - Multilink Frame Relay end-to-end (MLFR FRF.15)
 - Multilink PPP (MLPPP)
 - PPP over Frame Relay

Cables and connectors	<ul style="list-style-type: none">You can install any transceiver supported by the PIC. For information about installing and removing transceivers, see the hardware guide for your router.SONET/SDH OC12/STM4 small form-factor pluggable (SFP) transceivers:<ul style="list-style-type: none">Connector: Duplex LC/PC (Rx and Tx); single-mode fiberShort reach (SR-1) (model number: SFP-OC12-SR)Intermediate reach (IR-1) (model number: SFP-OC12-IR)Long reach (LR-1) (model number: SFP-OC12-LR) <p>Optical interface specifications—see “SONET/SDH OC12/STM4 Optical Interface Specifications” on page 78</p>
LEDs	<p>One tricolor per port:</p> <ul style="list-style-type: none">Off—Not enabledGreen—Online with no alarms or failuresYellow—Online with alarms for remote failuresRed—Active with a local alarm; router has detected a failure
Alarms, errors, and events	<p>SONET alarms:</p> <ul style="list-style-type: none">Alarm indication signal—line (AIS-L)Alarm indication signal—path (AIS-P)Bit error rate—signal degrade (BERR-SD)Bit error rate—signal fail (BERR-SF)Loss of frame (LOF)Loss of light (LOL)Loss of pointer (LOP)Loss of signal (LOS)Payload label mismatch (PLM-P)Remote defect indication—line (RDI-L)Remote defect indication—path (RDI-P)Remote error indication (REI)Payload unequipped (unequipped STS at path level) (UNEQ-P)Virtual container—alarm indication signal (VAIS)Virtual container—loss of pointer (VLOP)Virtual container—mismatch (VMIS)Virtual container—remote defect indication (VRD1)Virtual container—unequipped (VUNEQ)

SDH alarms:

- Administrative unit alarm indication signal (AU-AIS)
- Bit error rate—signal degrade (BERR-SD)
- Bit error rate—signal fail (BERR-SF)
- Bit interleaved parity (BIP) error B1, B2, B3
- Higher order path—alarm indication signal (HP-AIS)
- Higher order path—far-end receive failure (HP-FERF)
- Higher order path—payload label mismatch (HP-PLM)
- Higher order path—loss of pointer (HP-LOP)
- Higher order path—remote defect indication (HP-RDI)
- Higher order path—unequipped (HP-UNEQ)
- Loss of frame (LOF)
- Loss of light (LOL)
- Loss of signal (LOS)
- Multiplex section—alarm indication signal (MS-AIS)
- Multiplex section—far-end receive failure (MS-FERF)
- Multiplex section—remote defect indication (MS-RDI)
- Multiplex section—remote error indication (MS-REI)
- Phase lock loop (PLL)
- Remote error indication (REI)
- Severely errored frame (SEF)
- Tributary unit—alarm indication signal (TU-AIS)
- Tributary unit—loss of pointer (TU-LOP)
- Tributary unit—mismatch (TU-MIS)
- Tributary unit—remote defect indication (TU-RDI)
- Tributary unit—unequipped (TU-UNEQ)

- DS1 alarms:
 - Alarm indication signal (AIS)
 - Loss of frame (LOF)
 - Remote alarm indication signal (RAIS)
- DS1 error detection:
 - Bursty errored seconds (BES)
 - CRC errors
 - Errored seconds (ES)
 - Line errored seconds (LES)
 - Loss of framing seconds (LOFS)
 - Severely errored seconds (SES)
 - Severely errored framing seconds (SEFS)
 - Unavailable seconds (UAS)
- DS3 alarms:
 - Alarm indication signal (AIS)
 - Loss of frame (LOF)
 - Yellow alarm
- DS3 error detection:
 - C-bit code violations (CCV)
 - C-bit errored seconds (CES)
 - C-bit severely errored framing seconds (CEFS)
 - CRC errors
 - Excessive zeros (EXZ)
 - Far-end block error (FEBE)
 - Far-end receive failure (FERF)
 - Line errored seconds (LES)
 - Parity bit (P-bit) code violations (PCV)
 - Parity bit (P-bit) errored seconds (PES)
 - Parity bit (P-bit) severely errored framing seconds (PSES)
 - Severely errored framing seconds (SEFS)
 - Unavailable seconds (UAS)

Instrumentation
(counters)

- Layer 2 per-queue and per-channel packet and byte counters

Related Documentation

- [MX Series PIC Overview on page 29](#)
- [FPCs Supported by MX240, MX480, and MX960 Routers on page 30](#)
- [PICs Supported by MX240, MX480, and MX960 Routers on page 30](#)
- [High Availability Features on page 30](#)
- [SONET/SDH OC12/STM4 Optical Interface Specifications on page 78](#)

Channelized OC48/STM16 Enhanced IQ (IQE) PIC with SFP

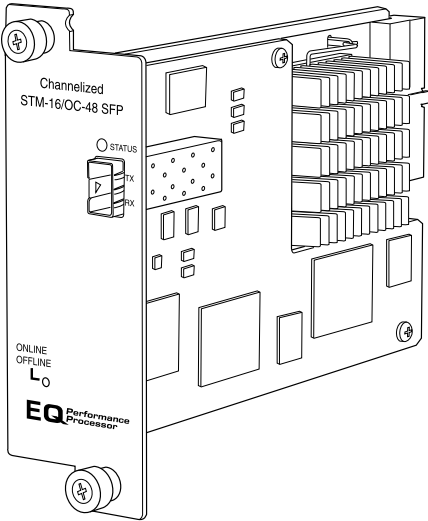

Software release	<ul style="list-style-type: none">• Junos 9.5 and later
Description	<ul style="list-style-type: none">• One OC48/STM16 port• SONET or SDH is configurable on a per-port granularity• SONET channelization:<ul style="list-style-type: none">• 4 OC12 channel• 16 OC3 channels• 48 DS3 channels• 672 DS1 channels• 975 DS0 channels• SDH channelization:<ul style="list-style-type: none">• 4 STM4 channel• 16 STM1 channels• 48 E3 channels• 504 E1 channels• 975 DS0 channels• Power requirement: 1.10 A @ 48V (53 W)• Model Number: PB-1CHOC48-STM16-IQE-SFP
Hardware features	<ul style="list-style-type: none">• Port is numbered 0.

- Software features
- Quality of service (QoS) per channel: weighted round-robin (WRR), random early detection (RED), weighted random early detection (WRED)
 - Enhanced fine-grained queuing per logical interface. See the *Class of Service Feature Guide for Routing Devices* for more information about class of service features.
 - Subrate and scrambling:
 - Digital Link/Quick Eagle
 - Kentrox
 - Larscom
 - ADTRAN
 - Verilink
 - Packet buffering, Layer 2 parsing
 - M13/C-bit parity encoding
 - DS3 far-end alarm and control (FEAC) channel support
 - Local line, remote line, and remote payload loopback testing
 - Simple Network Management Protocol (SNMP): OC12, OC3 MIB, DS3 MIB, T1 MIB
 - Dynamic, arbitrary channel configuration
 - Full bit error rate test (BERT)
 - Encapsulations:
 - Circuit cross-connect (CCC)
 - Translational cross-connect (TCC)
 - Extended Frame Relay for CCC and TCC
 - Flexible Frame Relay
 - Frame Relay
 - Frame Relay for CCC
 - Frame Relay for TCC
 - Frame Relay port CCC
 - High-Level Data Link Control (HDLC)
 - HDLC framing for CCC
 - HDLC framing for TCC
 - MPLS CCC
 - MPLS TCC
 - Multilink Frame Relay (MLFR) UNI NNI (MFR FRF.16)
 - Point-to-Point Protocol (PPP)
 - PPP for CCC
 - PPP for TCC
 - Encapsulations available only for DS1:
 - Multilink Frame Relay end-to-end (MLFR FRF.15)
 - Multilink PPP (MLPPP)
 - PPP over Frame Relay

- Cables and connectors
- SONET/SDH OC48/STM12 SFP small form-factor pluggable (SFP) transceivers:
 - Connector: Duplex LC/PC (Rx and Tx); single-mode fiber
 - Short reach (SR-1) (model number: SFP-1OC48-SR)
 - Intermediate reach (IR-1) (model number: SFP-1OC48-IR)
 - Long reach (LR-2) (model number: SFP-1OC48-LR)
- Optical interface specifications—see [“SONET/SDH OC48/STM16 Optical Interface Specifications” on page 80](#)

LEDs

One tricolor per port:

- Off—Not enabled
- Green—Online with no alarms or failures
- Yellow—Online with alarms for remote failures
- Red—Active with a local alarm; router has detected a failure

Alarms, errors, and events

SONET alarms:

- Alarm indication signal—line (AIS-L)
- Alarm indication signal—path (AIS-P)
- Bit error rate—signal degrade (BERR-SD)
- Bit error rate—signal fail (BERR-SF)
- Loss of frame (LOF)
- Loss of light (LOL)
- Loss of pointer (LOP)
- Loss of signal (LOS)
- Payload label mismatch (PLM-P)
- Remote defect indication—line (RDI-L)
- Remote defect indication—path (RDI-P)
- Remote error indication (REI)
- Payload unequipped (unequipped STS at path level) (UNEQ-P)
- Virtual container—alarm indication signal (VAIS)
- Virtual container—loss of pointer (VLOP)
- Virtual container—mismatch (VMIS)
- Virtual container—remote defect indication (VRDI)
- Virtual container—unequipped (VUNEQ)

SDH alarms:

- Administrative unit alarm indication signal (AU-AIS)
- Bit error rate—signal degrade (BERR-SD)
- Bit error rate—signal fail (BERR-SF)
- Bit interleaved parity (BIP) error B1, B2, B3
- Higher order path—alarm indication signal (HP-AIS)
- Higher order path—far-end receive failure (HP-FERF)
- Higher order path—payload label mismatch (HP-PLM)
- Higher order path—loss of pointer (HP-LOP)
- Higher order path—remote defect indication (HP-RDI)
- Higher order path—unequipped (HP-UNEQ)
- Loss of frame (LOF)
- Loss of light (LOL)
- Loss of signal (LOS)
- Multiplex section—alarm indication signal (MS-AIS)
- Multiplex section—far-end receive failure (MS-FERF)
- Multiplex section—remote defect indication (MS-RDI)
- Multiplex section—remote error indication (MS-REI)
- Phase lock loop (PLL)
- Remote error indication (REI)
- Severely errored frame (SEF)
- Tributary unit—alarm indication signal (TU-AIS)
- Tributary unit—loss of pointer (TU-LOP)
- Tributary unit—mismatch (TU-MIS)
- Tributary unit—remote defect indication (TU-RDI)
- Tributary unit—unequipped (TU-UNEQ)

- DS1 alarms:
 - Alarm indication signal (AIS)
 - Loss of frame (LOF)
 - Remote alarm indication signal (RAIS)
- DS1 error detection:
 - Bursty errored seconds (BES)
 - CRC errors
 - Errored seconds (ES)
 - Line errored seconds (LES)
 - Loss of framing seconds (LOFS)
 - Severely errored seconds (SES)
 - Severely errored framing seconds (SEFS)
 - Unavailable seconds (UAS)
- DS3 alarms:
 - Alarm indication signal (AIS)
 - Loss of frame (LOF)
 - Yellow alarm
- DS3 error detection:
 - C-bit code violations (CCV)
 - C-bit errored seconds (CES)
 - C-bit severely errored framing seconds (CEFS)
 - CRC errors
 - Excessive zeros (EXZ)
 - Far-end block error (FEBE)
 - Far-end receive failure (FERF)
 - Line errored seconds (LES)
 - Parity bit (P-bit) code violations (PCV)
 - Parity bit (P-bit) errored seconds (PES)
 - Parity bit (P-bit) severely errored framing seconds (PSES)
 - Severely errored framing seconds (SEFS)
 - Unavailable seconds (UAS)

Instrumentation
(counters)

- Layer 2 per-queue and per-channel packet and byte counters

Related Documentation

- [MX Series PIC Overview on page 29](#)
- [FPCs Supported by MX240, MX480, and MX960 Routers on page 30](#)
- [PICs Supported by MX240, MX480, and MX960 Routers on page 30](#)
- [High Availability Features on page 30](#)
- [SONET/SDH OC48/STM16 Optical Interface Specifications on page 80](#)

SONET/SDH OC3/STM1 (Multi-Rate) PIC with SFP

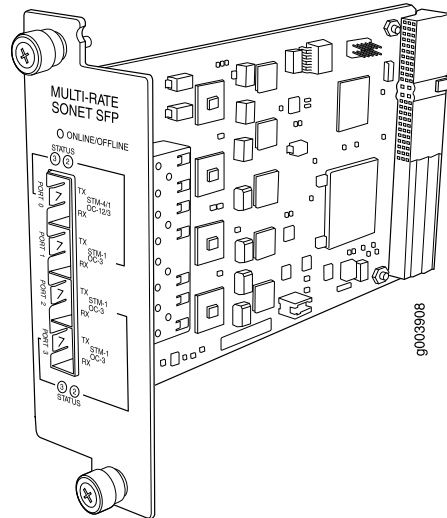

Software release	<ul style="list-style-type: none"> Junos 9.5 and later
Description	<ul style="list-style-type: none"> Rate-selectable using one of the following rates: <ul style="list-style-type: none"> 1-port OC12/STM4 1-port OC12c/STM4c 4-port OC3c/STM1c Power requirement: 0.40 A @ 48 V (19 W) Model Number: PB-4OC3-IOC12-SON-SFP
Hardware features	<ul style="list-style-type: none"> Multiplexing and demultiplexing Rate policing on input Rate shaping on output Packet buffering, Layer 2 parsing
Software features	<ul style="list-style-type: none"> Optical diagnostics and related alarms Per-port SONET/SDH framing Link aggregation Alarm and event counting and detection Dual-router automatic protection switching (APS) Multiprotocol Label Switching (MPLS) fast reroute Encapsulations: <ul style="list-style-type: none"> Circuit cross-connect (CCC) Translational cross-connect (TCC) Frame Relay High-Level Data Link Control (HDLC) Point-to-Point Protocol (PPP)

Cables and connectors You can install any transceiver supported by the PIC. For information about installing and removing transceivers, see the hardware guide for your router.

- Fiber-optic small form-factor pluggable (SFP) transceivers:
 - Connector: Duplex LC/PC (Rx and Tx)
 - SONET/SDH OC3/STM1 SFPs:
 - Multimode (model number: SFP-OC3-SR)
 - Intermediate reach (IR-1) (model number: SFP-OC3-IR)
 - Long reach (LR-1) (model number: SFP-OC3-LR)

Optical interface specifications—see [“SONET/SDH OC3/STM1 Optical Interface Specifications” on page 76](#)

- SONET/SDH OC12/STM4 SFPs:
 - Short reach (SR-1) (model number: SFP-OC12-SR)
 - Intermediate reach (IR-1) (model number: SFP-OC12-IR)
 - Long reach (LR-1) (model number: SFP-OC12-LR)

Optical interface specifications—see [“SONET/SDH OC12/STM4 Optical Interface Specifications” on page 78](#)

NOTE: To extend the life of the laser, when a PIC is not being actively used with any valid links, take the PIC offline until you are ready to establish a link to another device. For information about taking a PIC offline, see the **request chassis pic offline** command in the [CLI Explorer](#).

LEDs

One tricolor per port:

- Off—Not enabled
- Green—Online with no alarms or failures
- Yellow—Online with alarms for remote failures
- Red—Active with a local alarm; router has detected a failure

Alarms, errors, and events

- SONET alarms:
 - Alarm indication signal—line (AIS-L)
 - Alarm indication signal—path (AIS-P)
 - Bit error rate—signal degrade (BERR-SD)
 - Bit error rate—signal fail (BERR-SF)
 - Bit interleaved parity (BIP) error B1, B2, B3
 - Far-end bit error: remote error indication—line (REI-L), far-end line coding violations (CV-LFE)
 - Far-end bit error: remote error indication—path (REI-P), far-end path coding violations (CV-PFE)
 - Loss of frame (LOF)
 - Loss of pointer (LOP-P)
 - Loss of signal (LOS)
 - Payload label mismatch (PLM-P)
 - Payload unequipped (unequipped STS at path level) (UNEQ-P)
 - Remote defect indication—line (RDI-L)
 - Remote defect indication—path (RDI-P)
- SDH alarms:
 - Administrative unit alarm indication signal (AU-AIS)
 - Bit error rate signal degrade (BERR-SD)
 - Bit error rate signal fail (BERR-SF)
 - Bit interleaved parity (BIP) error B1, B2, B3
 - Higher order path—payload label mismatch (HP-PLM)
 - Higher order path—loss of pointer (HP-LOP)
 - Higher order path—remote defect indication (HP-RDI)
 - Higher order path—unequipped (HP-UNEQ)
 - Loss of frame (LOF)
 - Loss of signal (LOS)
 - Multiplex section—alarm indication signal (MS-AIS)
 - Multiplex section—remote defect indication (MS-RDI)
 - Multiplex section—remote error indication (MS-REI)
- Error detection:
 - Errored seconds (ES-S, ES-L, ES-P)
 - Far-end errored seconds (ES-LFE, ES-PFE)
 - Far-end severely errored seconds (SES-LFE, SES-PFE)
 - Far-end unavailable seconds (UAS-LFE, UAS-PFE)
 - Severely errored frames (SEF)
 - Severely errored framing seconds (SEFS-S)
 - Severely errored seconds (SES-S, SES-L, SES-P)
 - Unavailable seconds (UAS-L, UAS-P)

Related Documentation

- [MX Series PIC Overview on page 29](#)
- [FPCs Supported by MX240, MX480, and MX960 Routers on page 30](#)
- [PICs Supported by MX240, MX480, and MX960 Routers on page 30](#)
- [High Availability Features on page 30](#)

- SONET/SDH OC3/STM1 Optical Interface Specifications on page 76
- SONET/SDH OC12/STM4 Optical Interface Specifications on page 78

SONET/SDH OC12/STM4 (Multi-Rate) PIC with SFP

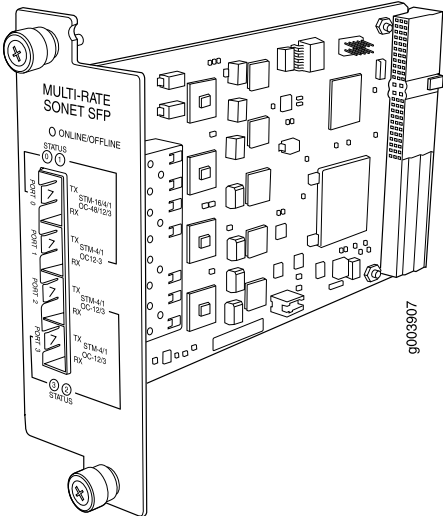

Software release	<ul style="list-style-type: none">• Junos 9.5 and later
Description	<ul style="list-style-type: none">• Rate-selectable using one of the following rates:<ul style="list-style-type: none">• 1-port OC12• 1-port OC48• 1-port OC48c• 4-port OC3c• 4-port OC12c• Power requirement: 0.40 A @ 48 V (19 W)• Model Number: PB-4OC3-4OC12-SON-SFP
Hardware features	<ul style="list-style-type: none">• Multiplexing and demultiplexing• Rate policing on input• Rate shaping on output• Packet buffering, Layer 2 parsing

Software features	<ul style="list-style-type: none">• Optical diagnostics and related alarms• Per-port SONET/SDH framing• Link aggregation• Alarm and event counting and detection• Dual-router automatic protection switching (APS)• Multiprotocol Label Switching (MPLS) fast reroute• Encapsulations:<ul style="list-style-type: none">• Circuit cross-connect (CCC)• Translational cross-connect (TCC)• Frame Relay• High-Level Data Link Control (HDLC)• Point-to-Point Protocol (PPP)
Cables and connectors	<p>You can install any transceiver supported by the PIC. For information about installing and removing transceivers, see the hardware guide for your router.</p> <ul style="list-style-type: none">• Fiber-optic small form-factor pluggable (SFP) transceivers:<ul style="list-style-type: none">• Connector: Duplex LC/PC (Rx and Tx)• SONET/SDH OC3/STM1 SFPs:<ul style="list-style-type: none">• Multimode (model number: SFP-OC3-SR)• Intermediate reach (IR-1) (model number: SFP-OC3-IR)• Long reach (LR-1) (model number: SFP-OC3-LR)Optical interface specifications—see “SONET/SDH OC3/STM1 Optical Interface Specifications” on page 76• SONET/SDH OC12/STM4 SFPs:<ul style="list-style-type: none">• Short reach (SR-1) (model number: SFP-OC12-SR)• Intermediate reach (IR-1) (model number: SFP-OC12-IR)• Long reach (LR-1) (model number: SFP-OC12-LR)Optical interface specifications—see “SONET/SDH OC12/STM4 Optical Interface Specifications” on page 78• SONET/SDH OC48/STM12 SFPs:<ul style="list-style-type: none">• Short reach (SR-1) (model number: SFP-IOC48-SR)• Intermediate reach (IR-1) (model number: SFP-IOC48-IR)• Long reach (LR-2) (model number: SFP-IOC48-LR)Optical interface specifications—see “SONET/SDH OC48/STM16 Optical Interface Specifications” on page 80 <p>NOTE: To extend the life of the laser, when a PIC is not being actively used with any valid links, take the PIC offline until you are ready to establish a link to another device. For information about taking a PIC offline, see the request chassis pic offline command in the CLI Explorer.</p>
LEDs	<p>One tricolor per port:</p> <ul style="list-style-type: none">• Off—Not enabled• Green—Online with no alarms or failures• Yellow—Online with alarms for remote failures• Red—Active with a local alarm; router has detected a failure

Alarms, errors, and events

- SONET alarms:
 - Alarm indication signal—line (AIS-L)
 - Alarm indication signal—path (AIS-P)
 - Bit error rate—signal degrade (BERR-SD)
 - Bit error rate—signal fail (BERR-SF)
 - Bit interleaved parity (BIP) error B1, B2, B3
 - Far-end bit error: remote error indication—line (REI-L), far-end line coding violations (CV-LFE)
 - Far-end bit error: remote error indication—path (REI-P), far-end path coding violations (CV-PFE)
 - Loss of frame (LOF)
 - Loss of pointer (LOP-P)
 - Loss of signal (LOS)
 - Payload label mismatch (PLM-P)
 - Payload unequipped (unequipped STS at path level) (UNEQ-P)
 - Remote defect indication—line (RDI-L)
 - Remote defect indication—path (RDI-P)
- SDH alarms:
 - Administrative unit alarm indication signal (AU-AIS)
 - Bit error rate signal degrade (BERR-SD)
 - Bit error rate signal fail (BERR-SF)
 - Bit interleaved parity (BIP) error B1, B2, B3
 - Higher order path—payload label mismatch (HP-PLM)
 - Higher order path—loss of pointer (HP-LOP)
 - Higher order path—remote defect indication (HP-RDI)
 - Higher order path—unequipped (HP-UNEQ)
 - Loss of frame (LOF)
 - Loss of signal (LOS)
 - Multiplex section—alarm indication signal (MS-AIS)
 - Multiplex section—remote defect indication (MS-RDI)
 - Multiplex section—remote error indication (MS-REI)
- Error detection:
 - Errored seconds (ES-S, ES-L, ES-P)
 - Far-end errored seconds (ES-LFE, ES-PFE)
 - Far-end severely errored seconds (SES-LFE, SES-PFE)
 - Far-end unavailable seconds (UAS-LFE, UAS-PFE)
 - Severely errored frames (SEF)
 - Severely errored framing seconds (SEFS-S)
 - Severely errored seconds (SES-S, SES-L, SES-P)
 - Unavailable seconds (UAS-L, UAS-P)

Related Documentation

- [MX Series PIC Overview on page 29](#)
- [FPCs Supported by MX240, MX480, and MX960 Routers on page 30](#)
- [PICs Supported by MX240, MX480, and MX960 Routers on page 30](#)
- [High Availability Features on page 30](#)

- SONET/SDH OC3/STM1 Optical Interface Specifications on page 76
- SONET/SDH OC12/STM4 Optical Interface Specifications on page 78
- SONET/SDH OC48/STM16 Optical Interface Specifications on page 80

SONET/SDH OC48/STM16 Enhanced IQ (IQE) PIC with SFP

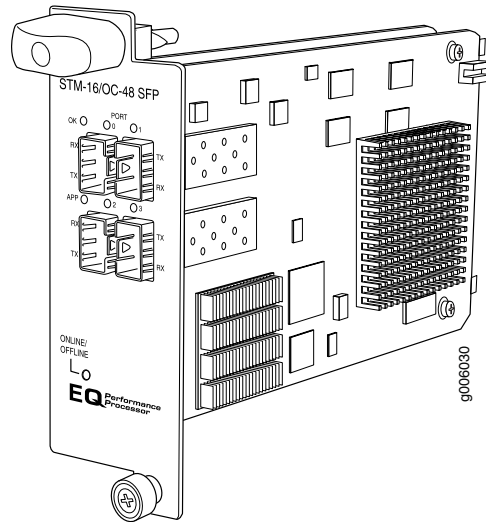

Software release	<ul style="list-style-type: none"> • Junos OS Release 10.4R2 and later (Type 3)
Description	<ul style="list-style-type: none"> • Four OC48/STM16 ports • Clear channel functionality • SONET and SDH is configured on a per-port granularity • Power requirement: 1.06 A @ 48 V (51 W) • Weight: 1.6 lb (0.725 kg) • Model number: PC-4OC48-STM16-IQE-SFP
Hardware features	<ul style="list-style-type: none"> • Ports are numbered: <ul style="list-style-type: none"> • Top row: 0 and 1 from left to right • Bottom row: 2 and 3 from left to right • Maximum transmission units (MTUs) of up to 9192 bytes

- Software features
- Quality of service (QoS) per channel: weighted round-robin (WRR), random early detection (RED), weighted random early detection (WRED)
 - Fine-grained egress queuing per logical interface. See the *Class of Service Feature Guide for Routing Devices* for more information about class-of-service features
 - Packet buffering
 - Local line and remote payload loopback testing
 - Optical diagnostics and monitoring
 - Clocking options: internal or external/loop mode. Each OC48 transmitter port is configured either in internal or external mode. The default clocking option is internal mode.
 - Encapsulations:
 - Extended Frame Relay for circuit cross-connect (CCC) and translational cross-connect (TCC)
 - Flexible Frame Relay
 - Frame Relay
 - Frame Relay for CCC
 - Frame Relay for TCC
 - Frame Relay port CCC
 - High-Level Data Link Control (HDLC)
 - HDLC framing for CCC
 - HDLC framing for TCC
 - MPLS CCC
 - MPLS TCC
 - Point-to-Point Protocol (PPP)
 - PPP for CCC
 - PPP for TCC

Cables and connectors You can install any transceiver supported by the PIC.

- Duplex LC/PC connector (Rx and Tx)
- SONET/SDH OC48/STM16 small form-factor pluggable (SFP) transceivers:
 - Short reach (SR-1) (model number: SFP-IOC48-SR)
 - Intermediate reach (IR-1) (model number: SFP-IOC48-IR)
 - Long reach (LR-1) (model number: SFP-IOC48-LR)

Optical interface specifications—see “[SONET/SDH OC48/STM16 Optical Interface Specifications](#)” on page 80

NOTE: To extend the life of the laser, when a PIC is not being actively used with any valid links, take the PIC offline until you are ready to establish a link to another device. For information about taking a PIC offline, see the **request chassis pic offline** command in the [CLI Explorer](#).

LEDs

OK LED, one tricolor:

- Off—PIC is offline and safe to remove from the router
- Green—PIC is operating normally
- Yellow—PIC is initializing
- Red—PIC has an error or failure

APP LED, one green per port:

- Off—Service is not running
- Green—Service is running under acceptable load

Port LEDs, one tricolor per port:

- Off—Not enabled
- Green—Online with no alarms or failures
- Yellow—Online with alarms for remote failures
- Red—Active with a local alarm; router has detected a failure

Alarms, errors, and events

SONET alarms:

- Loss of light (LOL)
- Phase lock loop (PLL)
- Loss of frame (LOF)
- Loss of signal (LOS)
- Severely errored frame (SEF)
- Alarm indicator signal—line (AIS-L)
- Alarm indicator signal—path (AIS-P)
- Loss of pointer (LOP)
- Bit error rate—signal degrade (BERR-SD)
- Bit error rate—signal fail (BERR-SF)
- Remote defect indicator—line (RDI-L)
- Remote defect indicator—path (RDI-P)
- Remote error indicator (REI)
- Unequipped (UNEQ)
- Payload label mismatch—path (PLM-P)

SDH alarms:

- Loss of light (LOL)
- Phase lock loop (PLL)
- Loss of frame (LOF)
- Loss of signal (LOS)
- Severely errored frame (SEF)
- Multiplex-section alarm indicator signal (MS-AIS)
- H Path alarm indicator signal (HP-AIS)
- Loss of pointer (LOP)
- Bit error rate—signal degrade (BERR-SD)
- Bit error rate—signal fail (BERR-SF)
- Multiplex section—far end receive failure (MS-FERF)
- High order path—far end receive failure (HP-FERF)
- Remote error indicator (REI)
- Unequipped (UNEQ)
- High order path—payload label mismatch - Path (HP-PLM)

Optical diagnostics related alarms:

NOTE: Transceivers from some vendors do not support these fields.

- Temperature high/low alarms and warnings
- Supply voltage high/low alarms and warnings
- Tx bias current high/low alarms and warnings
- Tx output power high/low alarms and warnings
- Rx received power high/low alarms and warnings

Related Documentation

- [MX Series PIC Overview on page 29](#)
- [FPCs Supported by MX240, MX480, and MX960 Routers on page 30](#)
- [PICs Supported by MX240, MX480, and MX960 Routers on page 30](#)

- High Availability Features on page 30
- SONET/SDH OC48/STM16 Optical Interface Specifications on page 80

SONET/SDH OC48/STM16 (Multi-Rate) PIC with SFP

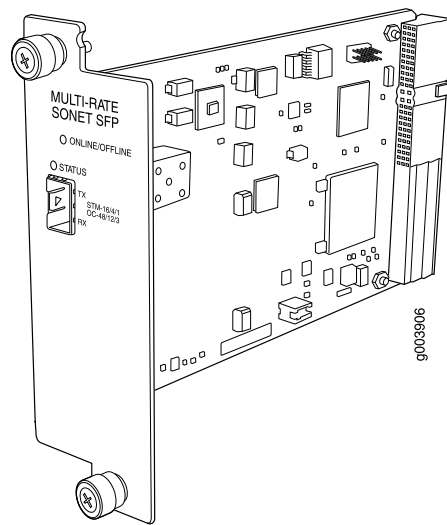

Software release	<ul style="list-style-type: none"> • Junos 9.5 and later
Description	<ul style="list-style-type: none"> • Rate-selectable using one of the following rates: <ul style="list-style-type: none"> • 1-port OC3c/STM1c • 1-port OC12/STM4 • 1-port OC12c/STM4c • 1-port OC48/STM16 • 1-port OC48c/STM16c • Power requirement: 0.20 A @ 48 V (9.5 W) • Model Number: PB-1OC48-SON-B-SFP
Hardware features	<ul style="list-style-type: none"> • Multiplexing and demultiplexing • Rate policing on input • Rate shaping on output • Packet buffering, Layer 2 parsing

Software features	<ul style="list-style-type: none"> • Optical diagnostics and related alarms • Per-port SONET/SDH framing • Link aggregation • Alarm and event counting and detection • Dual-router automatic protection switching (APS) • Multiprotocol Label Switching (MPLS) fast reroute • Encapsulations: <ul style="list-style-type: none"> • Circuit cross-connect (CCC) • Translational cross-connect (TCC) • Frame Relay • High-Level Data Link Control (HDLC) • Point-to-Point Protocol (PPP)
Cables and connectors	<p>You can install any transceiver supported by the PIC. For information about installing and removing transceivers, see the hardware guide for your router.</p> <ul style="list-style-type: none"> • Fiber-optic small form-factor pluggable (SFP) transceivers: <ul style="list-style-type: none"> • Connector: Duplex LC/PC (Rx and Tx) • SONET/SDH OC3/STM1 SFPs: <ul style="list-style-type: none"> • Multimode (model number: SFP-OC3-SR) • Intermediate reach (IR-1) (model number: SFP-OC3-IR) • Long reach (LR-1) (model number: SFP-OC3-LR) <p>Optical interface specifications—see “SONET/SDH OC3/STM1 Optical Interface Specifications” on page 76</p> • SONET/SDH OC12/STM4 SFPs: <ul style="list-style-type: none"> • Short reach (SR-1) (model number: SFP-OC12-SR) • Intermediate reach (IR-1) (model number: SFP-OC12-IR) • Long reach (LR-1) (model number: SFP-OC12-LR) <p>Optical interface specifications—see “SONET/SDH OC12/STM4 Optical Interface Specifications” on page 78</p> • SONET/SDH OC48/STM12 SFPs: <ul style="list-style-type: none"> • Short reach (SR-1) (model number: SFP-IOC48-SR) • Intermediate reach (IR-1) (model number: SFP-IOC48-IR) • Long reach (LR-2) (model number: SFP-IOC48-LR) <p>Optical interface specifications—see “SONET/SDH OC48/STM16 Optical Interface Specifications” on page 80</p> <p>NOTE: To extend the life of the laser, when a PIC is not being actively used with any valid links, take the PIC offline until you are ready to establish a link to another device. For information about taking a PIC offline, see the request chassis pic offline command in the CLI Explorer.</p>
LEDs	<p>One tricolor per port:</p> <ul style="list-style-type: none"> • Off—Not enabled • Green—Online with no alarms or failures • Yellow—Online with alarms for remote failures • Red—Active with a local alarm; router has detected a failure

Alarms, errors, and events

- SONET alarms:
 - Alarm indication signal—line (AIS-L)
 - Alarm indication signal—path (AIS-P)
 - Bit error rate—signal degrade (BERR-SD)
 - Bit error rate—signal fail (BERR-SF)
 - Bit interleaved parity (BIP) error B1, B2, B3
 - Far-end bit error: remote error indication—line (REI-L), far-end line coding violations (CV-LFE)
 - Far-end bit error: remote error indication—path (REI-P), far-end path coding violations (CV-PFE)
 - Loss of frame (LOF)
 - Loss of pointer (LOP-P)
 - Loss of signal (LOS)
 - Payload label mismatch (PLM-P)
 - Payload unequipped (unequipped STS at path level) (UNEQ-P)
 - Remote defect indication—line (RDI-L)
 - Remote defect indication—path (RDI-P)
- SDH alarms:
 - Administrative unit alarm indication signal (AU-AIS)
 - Bit error rate signal degrade (BERR-SD)
 - Bit error rate signal fail (BERR-SF)
 - Bit interleaved parity (BIP) error B1, B2, B3
 - Higher order path—payload label mismatch (HP-PLM)
 - Higher order path—loss of pointer (HP-LOP)
 - Higher order path—remote defect indication (HP-RDI)
 - Higher order path—unequipped (HP-UNEQ)
 - Loss of frame (LOF)
 - Loss of signal (LOS)
 - Multiplex section—alarm indication signal (MS-AIS)
 - Multiplex section—remote defect indication (MS-RDI)
 - Multiplex section—remote error indication (MS-REI)
- Error detection:
 - Errored seconds (ES-S, ES-L, ES-P)
 - Far-end errored seconds (ES-LFE, ES-PFE)
 - Far-end severely errored seconds (SES-LFE, SES-PFE)
 - Far-end unavailable seconds (UAS-LFE, UAS-PFE)
 - Severely errored frames (SEF)
 - Severely errored framing seconds (SEFS-S)
 - Severely errored seconds (SES-S, SES-L, SES-P)
 - Unavailable seconds (UAS-L, UAS-P)

Related Documentation

- [MX Series PIC Overview on page 29](#)
- [FPCs Supported by MX240, MX480, and MX960 Routers on page 30](#)
- [PICs Supported by MX240, MX480, and MX960 Routers on page 30](#)
- [High Availability Features on page 30](#)

- SONET/SDH OC3/STM1 Optical Interface Specifications on page 76
- SONET/SDH OC12/STM4 Optical Interface Specifications on page 78
- SONET/SDH OC48/STM16 Optical Interface Specifications on page 80

SONET/SDH OC48/STM16 PIC with SFP

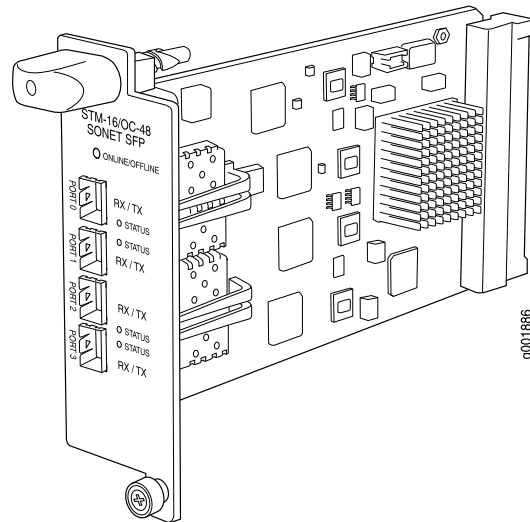

Software release	<ul style="list-style-type: none"> • Junos 9.4 and later
Description	<ul style="list-style-type: none"> • Four OC48 ports • Power requirement: 0.86 A @ 48 V (41.4 W) • Model Number: PC-4OC48-SON-SFP
Hardware features	<ul style="list-style-type: none"> • Rate policing on input • Rate shaping on output • Packet buffering, Layer 2 parsing
Software features	<ul style="list-style-type: none"> • Optical diagnostics and related alarms • Configuration of SONET or SDH framing on a per-port basis • SONET/SDH framing • Link aggregation • Alarm and event counting and detection • Dual-router automatic protection switching (APS) • Multiprotocol Label Switching (MPLS) fast reroute • Encapsulations: <ul style="list-style-type: none"> • High-Level Data Link Control (HDLC) • Frame Relay • Circuit cross-connect (CCC) • Translational cross-connect (TCC) • Point-to-Point Protocol (PPP)

Cables and connectors You can install any transceiver supported by the PIC. For information about installing and removing transceivers, see the hardware guide for your router.

- SONET/SDH OC48/STM12 small form-factor pluggable (SFP) transceivers:
 - Connector: Duplex LC/PC (Rx and Tx)
 - Short reach (SR-1) (model number: SFP-1OC48-SR)
 - Intermediate reach (IR-1) (model number: SFP-1OC48-IR)
 - Long reach (LR-2) (model number: SFP-1OC48-LR)

Optical interface specifications—see [“SONET/SDH OC12/STM4 Optical Interface Specifications” on page 78](#)

NOTE: To extend the life of the laser, when a PIC is not being actively used with any valid links, take the PIC offline until you are ready to establish a link to another device. For information about taking a PIC offline, see the **request chassis pic offline** command in the [CLI Explorer](#).

LEDs

One tricolor per port:

- Off—Not enabled
 - Green—Online with no alarms or failures
 - Yellow—Online with alarms for remote failures
 - Red—Active with a local alarm; router has detected a failure
-

Alarms, errors, and events

- SONET alarms:
 - Alarm indication signal—line (AIS-L)
 - Alarm indication signal—path (AIS-P)
 - Bit error rate—signal degrade (BERR-SD)
 - Bit error rate—signal fail (BERR-SF)
 - Bit interleaved parity (BIP) error B1, B2, B3
 - Far-end bit error: remote error indication—line (REI-L), far-end line coding violations (CV-LFE)
 - Far-end bit error: remote error indication—path (REI-P), far-end path coding violations (CV-PFE)
 - Loss of frame (LOF)
 - Loss of pointer (LOP-P)
 - Loss of signal (LOS)
 - Payload label mismatch (PLM-P)
 - Payload unequipped (unequipped STS at path level) (UNEQ-P)
 - Remote defect indication—line (RDI-L)
 - Remote defect indication—path (RDI-P)
- SDH alarms:
 - Administrative unit alarm indication signal (AU-AIS)
 - Bit error rate signal degrade (BERR-SD)
 - Bit error rate signal fail (BERR-SF)
 - Bit interleaved parity (BIP) error B1, B2, B3
 - Higher order path—payload label mismatch (HP-PLM)
 - Higher order path—loss of pointer (HP-LOP)
 - Higher order path—remote defect indication (HP-RDI)
 - Higher order path—unequipped (HP-UNEQ)
 - Loss of frame (LOF)
 - Loss of signal (LOS)
 - Multiplex section—alarm indication signal (MS-AIS)
 - Multiplex section—remote defect indication (MS-RDI)
 - Multiplex section—remote error indication (MS-REI)
- Error detection:
 - Errored seconds (ES-S, ES-L, ES-P)
 - Far-end errored seconds (ES-LFE, ES-PFE)
 - Far-end severely errored seconds (SES-LFE, SES-PFE)
 - Far-end unavailable seconds (UAS-LFE, UAS-PFE)
 - Severely errored framing (SEF)
 - Severely errored framing seconds (SEFS-S)
 - Severely errored seconds (SES-S, SES-L, SES-P)
 - Unavailable seconds (UAS-L, UAS-P)

Related Documentation

- [MX Series PIC Overview on page 29](#)
- [FPCs Supported by MX240, MX480, and MX960 Routers on page 30](#)
- [PICs Supported by MX240, MX480, and MX960 Routers on page 30](#)
- [High Availability Features on page 30](#)

- SONET/SDH OC48/STM16 Optical Interface Specifications on page 80

SONET/SDH OC192c/STM64 PIC

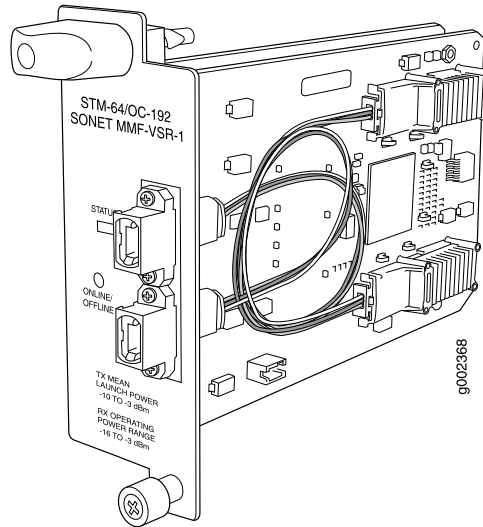

Software release	<ul style="list-style-type: none"> • Junos 9.4 and later
Description	<ul style="list-style-type: none"> • One OC192 port • Power requirement: 0.45 A @ 48 V (21.6 W) • Model Number: PC-1OC192-SON-VSR
Hardware features	<ul style="list-style-type: none"> • Multiplexing and demultiplexing • Rate policing on input • Rate shaping on output • Packet buffering, Layer 2 parsing
Software features	<ul style="list-style-type: none"> • SONET/SDH framing • Link aggregation • Alarm and event counting and detection • Dual-router automatic protection switching (APS) • Multiprotocol Label Switching (MPLS) fast reroute • Encapsulations: <ul style="list-style-type: none"> • High-Level Data Link Control (HDLC) • Frame Relay • Circuit cross-connect (CCC) • Translational cross-connect (TCC) • Point-to-Point Protocol (PPP)

- Cables and connectors
- Very short reach (VSR 1): 12-ribbon multimode fiber with MTP connector (Rx and Tx)
 - Fiber-optic 10-gigabit small form-factor pluggable (XFP) transceivers: 10GBASE-S very short reach (VSR-1) (model number: XFP-10G-S)
 - Optical interface specifications—see “[10-Gigabit Ethernet 10GBASE Optical Interface Specifications](#)” on page 54

NOTE: To extend the life of the laser, when a PIC is not being actively used with any valid links, take the PIC offline until you are ready to establish a link to another device. For information about taking a PIC offline, see the `request chassis pic offline` command in the [CLI Explorer](#).

LEDs

One tricolor LED per port:

- Off—Not enabled
- Green—Online with no alarms or failures
- Yellow—Online with alarms for remote failures
- Red—Active with a local alarm; router has detected a failure

Alarms, errors, and events

- SONET alarms:
 - Alarm indication signal—line (AIS-L)
 - Alarm indication signal—path (AIS-P)
 - Bit error rate—signal degrade (BERR-SD)
 - Bit error rate—signal fail (BERR-SF)
 - Bit interleaved parity (BIP) error B1, B2, B3
 - Far-end bit error: remote error indication—line (REI-L), far-end line coding violations (CV-LFE)
 - Far-end bit error: remote error indication—path (REI-P), far-end path coding violations (CV-PFE)
 - Loss of frame (LOF)
 - Loss of pointer (LOP-P)
 - Loss of signal (LOS)
 - Payload label mismatch (PLM-P)
 - Payload unequipped (unequipped STS at path level) (UNEQ-P)
 - Remote defect indication—line (RDI-L)
 - Remote defect indication—path (RDI-P)
- SDH alarms:
 - Administrative unit alarm indication signal (AU-AIS)
 - Bit error rate signal degrade (BERR-SD)
 - Bit error rate signal fail (BERR-SF)
 - Bit interleaved parity (BIP) error B1, B2, B3
 - Higher order path—payload label mismatch (HP-PLM)
 - Higher order path—loss of pointer (HP-LOP)
 - Higher order path—remote defect indication (HP-RDI)
 - Higher order path—unequipped (HP-UNEQ)
 - Loss of frame (LOF)
 - Loss of signal (LOS)
 - Multiplex section—alarm indication signal (MS-AIS)
 - Multiplex section—remote defect indication (MS-RDI)
 - Multiplex section—remote error indication (MS-REI)
- Error detection:
 - Errored seconds (ES-S, ES-L, ES-P)
 - Far-end errored seconds (ES-LFE, ES-PFE)
 - Far-end severely errored seconds (SES-LFE, SES-PFE)
 - Far-end unavailable seconds (UAS-LFE, UAS-PFE)
 - Severely errored framing (SEF)
 - Severely errored framing seconds (SEFS-S)
 - Severely errored seconds (SES-S, SES-L, SES-P)
 - Unavailable seconds (UAS-L, UAS-P)

Related Documentation

- [MX Series PIC Overview on page 29](#)
- [FPCs Supported by MX240, MX480, and MX960 Routers on page 30](#)
- [PICs Supported by MX240, MX480, and MX960 Routers on page 30](#)
- [High Availability Features on page 30](#)

- 10-Gigabit Ethernet 10GBASE Optical Interface Specifications on page 54

SONET/SDH OC192c/STM64 PIC with XFP

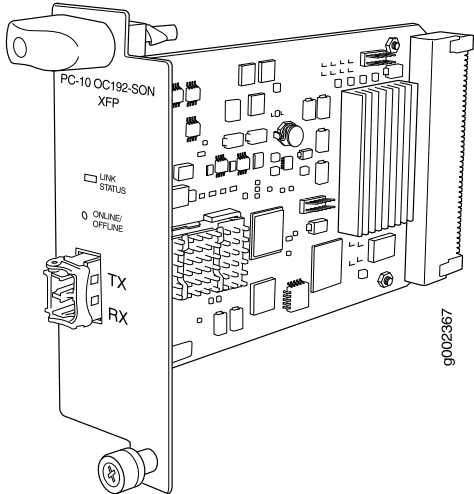

Software release	<ul style="list-style-type: none">• Junos 9.4 and later
Description	<ul style="list-style-type: none">• One OC192 port• Power requirement: 0.52A @ 48 V (25 W)• Model number: PB-1OC192-SON-XFP
Hardware features	<ul style="list-style-type: none">• Multiplexing and demultiplexing• Rate policing on input• Rate shaping on output• Packet buffering, Layer 2 parsing
Software features	<ul style="list-style-type: none">• SONET/SDH framing• Link aggregation• Alarm and event counting and detection• Dual-router automatic protection switching (APS)• Multiprotocol Label Switching (MPLS) fast reroute• Encapsulations:<ul style="list-style-type: none">• Circuit cross-connect (CCC)• Translational cross-connect (TCC)• Frame Relay• High-Level Data Link Control (HDLC)• Point-to-Point Protocol (PPP)

- Cables and connectors
- Fiber-optic 10-gigabit small form-factor pluggable (XFP) transceivers:
 - Connector: Duplex LC/PC (Rx and Tx)
 - Short reach (SR-1) (model number: XFP-10G-L-OC192-SR1)
 - Intermediate reach (IR-2) (model number: XFP-10G-E-OC192-IR2)
 - Long reach (LR-2) (model number: XFP-10G-Z-OC192-LR2)
- Optical interface specifications—see [“SONET/SDH OC192/STM64 Optical Interface Specifications” on page 83](#)

NOTE: To extend the life of the laser, when a PIC is not being actively used with any valid links, take the PIC offline until you are ready to establish a link to another device. For information about taking a PIC offline, see the **request chassis pic offline** command in the [CLI Explorer](#).

- LEDs
- One tricolor LED per port:
- Off—Not enabled
 - Green—Online with no alarms or failures
 - Yellow—Online with alarms for remote failures
 - Red—Active with a local alarm; router has detected a failure
-

Alarms, errors, and events

- SONET alarms:
 - Alarm indication signal—line (AIS-L)
 - Alarm indication signal—path (AIS-P)
 - Bit error rate—signal degrade (BERR-SD)
 - Bit error rate—signal fail (BERR-SF)
 - Bit interleaved parity (BIP) error B1, B2, B3
 - Far-end bit error: remote error indication—line (REI-L), far-end line coding violations (CV-LFE)
 - Far-end bit error: remote error indication—path (REI-P), far-end path coding violations (CV-PFE)
 - Loss of frame (LOF)
 - Loss of pointer (LOP-P)
 - Loss of signal (LOS)
 - Payload label mismatch (PLM-P)
 - Payload unequipped (unequipped STS at path level) (UNEQ-P)
 - Remote defect indication—line (RDI-L)
 - Remote defect indication—path (RDI-P)
- SDH alarms:
 - Administrative unit alarm indication signal (AU-AIS)
 - Bit error rate signal degrade (BERR-SD)
 - Bit error rate signal fail (BERR-SF)
 - Bit interleaved parity (BIP) error B1, B2, B3
 - Higher order path—payload label mismatch (HP-PLM)
 - Higher order path—loss of pointer (HP-LOP)
 - Higher order path—remote defect indication (HP-RDI)
 - Higher order path—unequipped (HP-UNEQ)
 - Loss of frame (LOF)
 - Loss of signal (LOS)
 - Multiplex section—alarm indication signal (MS-AIS)
 - Multiplex section—remote defect indication (MS-RDI)
 - Multiplex section—remote error indication (MS-REI)
- Error detection:
 - Errored seconds (ES-S, ES-L, ES-P)
 - Far-end errored seconds (ES-LFE, ES-PFE)
 - Far-end severely errored seconds (SES-LFE, SES-PFE)
 - Far-end unavailable seconds (UAS-LFE, UAS-PFE)
 - Severely errored framing (SEF)
 - Severely errored framing seconds (SEFS-S)
 - Severely errored seconds (SES-S, SES-L, SES-P)
 - Unavailable seconds (UAS-L, UAS-P)

Related Documentation

- [MX Series PIC Overview on page 29](#)
- [FPCs Supported by MX240, MX480, and MX960 Routers on page 30](#)
- [PICs Supported by MX240, MX480, and MX960 Routers on page 30](#)
- [High Availability Features on page 30](#)

- [10-Gigabit Ethernet 10GBASE Optical Interface Specifications on page 54](#)

PART 3

Protocol and Application Support

- DPC Protocol and Application Support for MX240, MX480, and MX960 on page 297
- MPC Protocol and Application Support for MX240, MX480, MX960, MX2010, and MX2020 on page 319

CHAPTER 11

DPC Protocol and Application Support for MX240, MX480, and MX960

- Protocols and Applications Supported by DPCs and Enhanced DPCs (DPC and DPCE-R) on page 297
- Protocols and Applications Supported by Enhanced Ethernet Services DPCs (DPCE-X) on page 303
- Protocols and Applications Supported by Enhanced Queuing IP Services DPCs (DPCE-R-Q) on page 308
- Protocols and Applications Supported by Enhanced Queuing Ethernet Services DPCs (DPCE-X-Q) on page 312
- Protocols and Applications Supported by the Multiservices DPC (MS-DPC) on page 317

Protocols and Applications Supported by DPCs and Enhanced DPCs (DPC and DPCE-R)

Table 68 on page 297 contains the first Junos OS Release support for protocols and applications on the MX240, MX480, and MX960 DPCs and Enhanced DPCs. A dash indicates that the protocol or application is not supported.

Table 68: Protocols and Applications Supported by the DPCs and Enhanced DPCs (DPC and DPCE-R)

Protocol or Application	First Junos OS Release Supported by DPC Model Number (DPC Name)				
	DPC-R-4XGE-XFP DPC-R-40GE-SFP (DPC)	DPCE-R-2XGE-XFP (Enhanced DPC)	DPCE-R-4XGE-XFP DPCE-R-40GE-SFP (Enhanced DPC)	DPCE-R-40GE-TX (Tri-Rate Enhanced DPC)	DPCE-R-20GE-2XGE (Multi-Rate Enhanced DPC)
<i>Access Node Control Protocol (ANCP)</i>	9.4	9.4	9.4	9.4	9.4
Accepts traffic destined for GRE tunnels or DVMRP (IP-in-IP) tunnels	8.2	9.1	8.4	9.1	9.2

Table 68: Protocols and Applications Supported by the DPCs and Enhanced DPCs (DPC and DPCE-R) (continued)

Protocol or Application	First Junos OS Release Supported by DPC Model Number (DPC Name)				
	DPC-R-4XGE-XFP DPC-R-40GE-SFP (DPC)	DPCE-R-2XGE-XFP (Enhanced DPC)	DPCE-R-4XGE-XFP DPCE-R-40GE-SFP (Enhanced DPC)	DPCE-R-40GE-TX (Tri-Rate Enhanced DPC)	DPCE-R-20GE-2XGE (Multi-Rate Enhanced DPC)
<i>Bidirectional Forwarding Detection protocol (BFD)</i>	8.2	9.1	8.4	9.1	9.2
<i>Border Gateway Protocol (BGP)</i>	8.2	9.1	8.4	9.1	9.2
<i>BGP/Multiprotocol Label Switching (MPLS) virtual private networks (VPNs)</i>	8.2	9.1	8.4	9.1	9.2
<i>Distance Vector Multicast Routing Protocol (DVMRP) and generic routing encapsulation (GRE) support—access side and server side</i>	8.2	9.1	8.4	9.1	9.2
<i>IEEE 802.1ag Ethernet OAM Continuity Check protocol</i>	8.4	9.1	8.4	9.1	9.2
<i>IEEE 802.1ag Ethernet OAM Linktrace protocol</i>	9.0	9.1	9.0	9.1	9.2
<i>IEEE 802.1ag Ethernet OAM Loopback protocol</i>	9.1	9.1	9.1	9.1	9.2
<i>Firewall filters</i>	8.2	9.1	8.4	9.1	9.2
<i>Flexible Ethernet encapsulation</i>	8.2	9.1	8.4	9.1	9.2
<i>Graceful Routing Engine Switchover (GRES)</i>	8.3	9.1	8.4	9.1	9.2

Table 68: Protocols and Applications Supported by the DPCs and Enhanced DPCs (DPC and DPCE-R) (continued)

Protocol or Application	First Junos OS Release Supported by DPC Model Number (DPC Name)				
	DPC-R-4XGE-XFP DPC-R-40GE-SFP (DPC)	DPCE-R-2XGE-XFP (Enhanced DPC)	DPCE-R-4XGE-XFP DPCE-R-40GE-SFP (Enhanced DPC)	DPCE-R-40GE-TX (Tri-Rate Enhanced DPC)	DPCE-R-20GE-2XGE (Multi-Rate Enhanced DPC)
Ingress hierarchical quality of service (HQoS) shaping and <i>hierarchical-scheduler</i> :	–	–	–	–	–
<ul style="list-style-type: none"> • Group of virtual LANs (VLANs) level • Virtual LAN (VLAN) level • Port level 					
IPv4	8.2	9.1	8.4	9.1	9.2
<i>IP multicast</i>	8.2	9.1	8.4	9.1	9.2
IPv6	8.2	9.1	8.4	9.1	9.2
<i>IPv6 multicast</i>	8.2	9.1	8.4	9.1	9.2
<i>IPv6 Neighbor Discovery</i>	8.2	9.1	8.4	9.1	9.2
<i>Intermediate System-to-Intermediate System (IS-IS)</i>	8.2	9.1	8.4	9.1	9.2
Layer 2 frame filtering	8.2	9.1	8.4	9.1	9.2
<i>IEEE 802.3ad link aggregation</i>	8.2	9.1	8.4	9.1	9.2
<i>Link Aggregation Control Protocol (LACP)</i>	8.2	9.1	8.4	9.1	9.2
Local loopback	8.2	9.1	8.4	9.1	9.2
MAC learning, policing, accounting, and filtering	8.2	9.1	8.4	9.1	9.2
<i>IEEE 802.1s Multiple Spanning Tree Protocol (MSTP) (part of IEEE 802.1Q VLANs)</i>	8.4	9.1	8.4	9.1	9.2

Table 68: Protocols and Applications Supported by the DPCs and Enhanced DPCs (DPC and DPCE-R) (continued)

Protocol or Application	First Junos OS Release Supported by DPC Model Number (DPC Name)				
	DPC-R-4XGE-XFP DPC-R-40GE-SFP (DPC)	DPCE-R-2XGE-XFP (Enhanced DPC)	DPCE-R-4XGE-XFP DPCE-R-40GE-SFP (Enhanced DPC)	DPCE-R-40GE-TX (Tri-Rate Enhanced DPC)	DPCE-R-20GE-2XGE (Multi-Rate Enhanced DPC)
<i>Multi-chassis link aggregation (MC-AE)</i>	10.0	10.0	10.0	10.0	10.0
Multiple tag protocol identifiers (TPIDs)	8.2	9.1	8.4	9.1	9.2
<i>Multiprotocol Label Switching (MPLS)</i>	8.2	9.1	8.4	9.1	9.2
<i>IEEE 802.1ak-2007 Multiple VLAN Registration Protocol (MVRP)</i>	10.1	10.1	10.1	10.1	10.1
IEEE 802.3ah OAM <ul style="list-style-type: none"> Discovery and link monitoring Fault signaling and detection Remote loopback 	8.2	9.1	8.4	9.1	9.2
<i>Multitopology Routing (MTR)</i>	9.0	9.1	9.0	9.1	9.2
<i>Open Shortest Path First (OSPF)</i>	8.2	9.1	8.4	9.1	9.2
Packet mirroring	8.2	9.1	8.4	9.1	9.2
IEEE 802.1ah provider backbone bridges (PBB)	10.0	10.0	10.0	10.0	10.0

Table 68: Protocols and Applications Supported by the DPCs and Enhanced DPCs (DPC and DPCE-R) (continued)

Protocol or Application	First Junos OS Release Supported by DPC Model Number (DPC Name)				
	DPC-R-4XGE-XFP DPC-R-40GE-SFP (DPC)	DPCE-R-2XGE-XFP (Enhanced DPC)	DPCE-R-4XGE-XFP DPCE-R-40GE-SFP (Enhanced DPC)	DPCE-R-40GE-TX (Tri-Rate Enhanced DPC)	DPCE-R-20GE-2XGE (Multi-Rate Enhanced DPC)
Quality of service (QoS) per port:	8.2	9.1	8.4	9.1	9.2
<ul style="list-style-type: none"> 8 queues per port Shaping at queue level Scheduling of queues based on weighted round-robin (WRR) per priority class Random early detection (RED) Weighted random early detection (WRED) 					
<ul style="list-style-type: none"> Shaping at port level 	–	–	–	–	–
Quality of service (QoS) per virtual LAN (VLAN):	8.2	9.1	8.4	9.1	9.2
<ul style="list-style-type: none"> Accounting, filtering, and policing IEEE 802.1p rewrite Classification Tricolor marking 					
Quality of service (QoS) queuing per virtual LAN (VLAN)	–	–	–	–	–
<i>IEEE 802.1w Rapid Spanning Tree Protocol (RSTP)</i>	8.4	9.1	8.4	9.1	9.2
Per-VLAN Spanning Tree (PVST)+	9.0	9.1	9.0	9.1	9.2
<i>RSVP</i>	8.2	9.1	8.4	9.1	9.2
<i>Routing Information Protocol (RIP)</i>	8.2	9.1	8.4	9.1	9.2

Table 68: Protocols and Applications Supported by the DPCs and Enhanced DPCs (DPC and DPCE-R) (continued)

Protocol or Application	First Junos OS Release Supported by DPC Model Number (DPC Name)				
	DPC-R-4XGE-XFP DPC-R-40GE-SFP (DPC)	DPCE-R-2XGE-XFP (Enhanced DPC)	DPCE-R-4XGE-XFP DPCE-R-40GE-SFP (Enhanced DPC)	DPCE-R-40GE-TX (Tri-Rate Enhanced DPC)	DPCE-R-20GE-2XGE (Multi-Rate Enhanced DPC)
<i>SNMP</i>	8.2	9.1	8.4	9.1	9.2
<i>IEEE 802.1D Spanning Tree Protocol (STP)</i>	8.4	9.1	8.4	9.1	9.2
• Access Node Control Protocol (ANCP)	9.4	9.4	9.4	9.4	9.4
• Dynamic profiles	9.2	9.2	9.2	9.2	9.2
• Dynamic VLANs	–	9.5	9.5	9.5	9.5
• Enhanced Dynamic Host Configuration Protocol (DHCP) local server	9.3	9.3	9.3	9.3	9.3
• Enhanced DHCP relay	9.3	9.3	9.3	9.3	9.3
• Firewall filters	9.2	9.2	9.2	9.2	9.2
• Internet Group Management Protocol (IGMP)	9.2	9.2	9.2	9.2	9.2
• QoS	9.2	9.2	9.2	9.2	9.2
• Subscriber Secure Policy	9.4	9.4	9.4	9.4	9.4
<i>Two-Way Active Measurement Protocol (TWAMP)</i>	9.5	9.5	9.5	9.5	9.5

Table 68: Protocols and Applications Supported by the DPCs and Enhanced DPCs (DPC and DPCE-R) (continued)

Protocol or Application	First Junos OS Release Supported by DPC Model Number (DPC Name)				
	DPC-R-4XGE-XFP DPC-R-40GE-SFP (DPC)	DPCE-R-2XGE-XFP (Enhanced DPC)	DPCE-R-4XGE-XFP DPCE-R-40GE-SFP (Enhanced DPC)	DPCE-R-40GE-TX (Tri-Rate Enhanced DPC)	DPCE-R-20GE-2XGE (Multi-Rate Enhanced DPC)
<i>IEEE 802.1Q VLANs:</i>	8.2	9.1	8.4	9.1	9.2
<ul style="list-style-type: none"> VLAN stacking and rewriting Channels defined by two stacked VLAN tags Flexible VLAN tagging IP service for nonstandard TPID and stacked VLAN tags 					
<i>Virtual private LAN service (VPLS)</i>	8.2	9.1	8.4	9.1	9.2
Virtual private network (VPN)	8.2	9.1	8.4	9.1	9.2
<i>Virtual Router Redundancy Protocol (VRRP) for IPv4</i>	8.2	9.1	8.4	9.1	9.2

Related Documentation

- [DPCs Supported on MX240, MX480, and MX960 Routers on page 7](#)
- [Protocols and Applications Supported by Enhanced Ethernet Services DPCs \(DPCE-X\) on page 303](#)
- [Protocols and Applications Supported by Enhanced Queuing IP Services DPCs \(DPCE-R-Q\) on page 308](#)
- [Protocols and Applications Supported by Enhanced Queuing Ethernet Services DPCs \(DPCE-X-Q\) on page 312](#)
- [Protocols and Applications Supported by the Multiservices DPC \(MS-DPC\) on page 317](#)

Protocols and Applications Supported by Enhanced Ethernet Services DPCs (DPCE-X)

Table 69 on page 304 contains the first Junos OS Release support for protocols and applications on the MX240, MX480, and MX960 Enhanced Ethernet Services DPCs. A dash indicates that the protocol or application is not supported.

Table 69: Protocols and Applications Supported by the Enhanced Ethernet Services DPCs (DPCE-X)

Protocol or Application	First Junos OS Release Supported by DPC Model Number (DPC Name)		
	DPCE-X-4XGE-XFP	DPCE-X-40GE-TX	DPCE-X-20GE-2XGE
	(Enhanced Ethernet Services DPC)	(Tri-Rate Enhanced Ethernet Services DPC)	(Multi-Rate Enhanced Ethernet Services DPC)
Access Node Control Protocol (ANCP)	9.4	9.4	9.4
Accepts traffic destined for GRE tunnels or DVMRP (IP-in-IP) tunnels	8.4	9.1	9.2
Bidirectional Forwarding Detection protocol (BFD)	8.4	9.1	9.2
Border Gateway Protocol (BGP)	8.4	9.1	9.2
BGP/Multiprotocol Label Switching (MPLS) virtual private networks (VPNs)	8.4	9.1	9.2
Distance Vector Multicast Routing Protocol (DVMRP) and generic routing encapsulation (GRE) support—access side and server side	8.4	9.1	9.2
IEEE 802.1ag Ethernet OAM Continuity Check protocol	8.4	9.1	9.2
IEEE 802.1ag Ethernet OAM Linktrace protocol	9.0	9.1	9.2
IEEE 802.1ag Ethernet OAM Loopback protocol	9.1	9.1	9.2
Firewall filters	8.4 (Limited filter terms)	9.1 (Limited filter terms)	9.2 (Limited filter terms)
Flexible Ethernet encapsulation	8.4	9.1	9.2
Graceful Routing Engine Switchover (GRES)	8.4	9.1	9.2
Ingress hierarchical quality of service (HQoS) shaping and scheduling: <ul style="list-style-type: none"> • Group of virtual LANs (VLANs) level • Virtual LAN (VLAN) level • Port level 	–	–	–
Intermediate System-to-Intermediate System (IS-IS)	8.4	9.1	9.2

Table 69: Protocols and Applications Supported by the Enhanced Ethernet Services DPCs (DPCE-X) (continued)

Protocol or Application	First Junos OS Release Supported by DPC Model Number (DPC Name)		
	DPCE-X-4XGE-XFP DPCE-X-40GE-SFP (Enhanced Ethernet Services DPC)	DPCE-X-40GE-TX (Tri-Rate Enhanced Ethernet Services DPC)	DPCE-X-20GE-2XGE (Multi-Rate Enhanced Ethernet Services DPC)
IPv4 (No BGP)	8.4	9.1	9.2)
IP multicast (No BGP)	8.4	9.1	9.2
IPv6 (No BGP)	8.4	9.1	9.2)
IPv6 multicast (No BGP)	8.4	9.1	9.2)
IPv6 Neighbor Discovery (No BGP)	8.4	9.1)	9.2)
Layer 2 frame filtering	8.4	9.1	9.2
IEEE 802.3ad link aggregation	8.4	9.1	9.2
Link Aggregation Control Protocol (LACP)	8.4	9.1	9.2
Local loopback	8.4	9.1	9.2
MAC learning, policing, accounting, and filtering	8.4	9.1	9.2
IEEE 802.1s Multiple Spanning Tree Protocol (MSTP) (part of IEEE 802.1Q VLANs)	8.4	9.1	9.2
Multiple tag protocol identifiers (TPIDs)	8.4	9.1	9.2
Multiprotocol Label Switching (MPLS)	8.4	9.1	9.2
IEEE 802.3ah OAM <ul style="list-style-type: none"> Discovery and link monitoring Fault signaling and detection Remote loopback 	8.4	9.1	9.2
Multitopology Routing (MTR)	9.0	9.1	9.2
Open Shortest Path First (OSPF)	8.4	9.1	9.2
Packet mirroring	8.4	9.1	9.2

Table 69: Protocols and Applications Supported by the Enhanced Ethernet Services DPCs (DPCE-X) (continued)

Protocol or Application	First Junos OS Release Supported by DPC Model Number (DPC Name)		
	DPCE-X-4XGE-XFP	DPCE-X-40GE-TX	DPCE-X-20GE-2XGE
	DPCE-X-40GE-SFP (Enhanced Ethernet Services DPC)	DPCE-X-40GE-TX (Tri-Rate Enhanced Ethernet Services DPC)	DPCE-X-20GE-2XGE (Multi-Rate Enhanced Ethernet Services DPC)
Quality of service (QoS) per port: <ul style="list-style-type: none"> 8 queues per port Shaping at queue level Scheduling of queues based on weighted round-robin (WRR) per priority class Random early detection (RED) Weighted random early detection (WRED) 	8.4	9.1	9.2
Quality of service (QoS) per virtual LAN (VLAN): <ul style="list-style-type: none"> Accounting, filtering, and policing IEEE 802.1p rewrite Classification Tricolor marking 	8.4	9.1	9.2
Quality of service (QoS) queuing per virtual LAN (VLAN)	–	–	–
IEEE 802.1w Rapid Spanning Tree Protocol (RSTP)	8.4	9.1	9.2
Per-VLAN Spanning Tree (PVST)+	9.0	9.1	9.2
RSVP	8.4	9.1	9.2
Routing Information Protocol (RIP)	8.4	9.1	9.2
SNMP	8.4	9.1	9.2
IEEE 802.1D Spanning Tree Protocol (STP)	8.4	9.1	9.2
Subscriber Management:	9.4	9.4	9.4
<ul style="list-style-type: none"> Access Node Control Protocol (ANCP) 	9.4	9.4	9.4
<ul style="list-style-type: none"> Dynamic profiles 	9.2	9.2	9.2
<ul style="list-style-type: none"> Dynamic VLANs 	9.5	9.5	9.5

Table 69: Protocols and Applications Supported by the Enhanced Ethernet Services DPCs (DPCE-X) (continued)

Protocol or Application	First Junos OS Release Supported by DPC Model Number (DPC Name)		
	DPCE-X-4XGE-XFP	DPCE-X-40GE-TX	DPCE-X-20GE-2XGE
	(Enhanced Ethernet Services DPC)	(Tri-Rate Enhanced Ethernet Services DPC)	(Multi-Rate Enhanced Ethernet Services DPC)
<ul style="list-style-type: none"> Enhanced Dynamic Host Configuration Protocol (DHCP) local server 	9.3	9.3	9.3
<ul style="list-style-type: none"> Enhanced DHCP relay 	9.3	9.3	9.3
<ul style="list-style-type: none"> Firewall filters 	9.2	9.2	9.2
<ul style="list-style-type: none"> Internet Group Management Protocol (IGMP) 	9.2	9.2	9.2
<ul style="list-style-type: none"> QoS 	9.2	9.2	9.2
<ul style="list-style-type: none"> Subscriber Secure Policy 	9.4	9.4	9.4
Two-Way Active Measurement Protocol (TWAMP)	9.5	9.5	9.5
IEEE 802.1Q VLANs: <ul style="list-style-type: none"> VLAN stacking and rewriting Channels defined by two stacked VLAN tags Flexible VLAN tagging IP service for nonstandard TPID and stacked VLAN tags 	8.4	9.1	9.2
Virtual private LAN service (VPLS)	8.4	9.1	9.2
Virtual private network (VPN) (L2 VPN only)	8.4	9.1	9.2
Virtual Router Redundancy Protocol (VRRP) for IPv4	8.4	9.1	9.2

Related Documentation

- [DPCs Supported on MX240, MX480, and MX960 Routers on page 7](#)
- [Protocols and Applications Supported by DPCs and Enhanced DPCs \(DPC and DPCE-R\) on page 297](#)
- [Protocols and Applications Supported by Enhanced Queuing IP Services DPCs \(DPCE-R-Q\) on page 308](#)

- [Protocols and Applications Supported by Enhanced Queuing Ethernet Services DPCs \(DPCE-X-Q\) on page 312](#)
- [Protocols and Applications Supported by the Multiservices DPC \(MS-DPC\) on page 317](#)

Protocols and Applications Supported by Enhanced Queuing IP Services DPCs (DPCE-R-Q)

Table 70 on page 308 contains the first Junos OS Release support for protocols and applications on the MX240, MX480, and MX960 Enhanced Queuing IP Services DPCs. A dash indicates that the protocol or application is not supported.

Table 70: Protocols and Applications Supported by the Enhanced Queuing IP Services DPCs (DPCE-R-Q)

Protocol or Application	First Junos OS Release Supported by DPC Model Number (DPC Name)		
	DPCE-R-Q-4XGE-XFP DPCE-R-Q-40GE-SFP Enhanced Queuing IP Services DPC	DPCE-R-Q-20GE-SFP Enhanced Queuing IP Services DPC	DPCE-R-Q-20GE-2XGE Enhanced Queuing IP Services Multi-Rate DPC
Access Node Control Protocol (ANCP)	9.4	9.4	9.4
Accepts traffic destined for GRE tunnels or DVMRP (IP-in-IP) tunnels	8.5	9.1	9.3
Bidirectional Forwarding Detection protocol (BFD)	8.5	9.1	9.3
Border Gateway Protocol (BGP)	8.5	9.1	9.3
BGP/Multiprotocol Label Switching (MPLS) virtual private networks (VPNs)	8.5	9.1	9.3
Distance Vector Multicast Routing Protocol (DVMRP) and generic routing encapsulation (GRE) support—access side and server side	8.5	9.1	9.3
IEEE 802.1ag Ethernet OAM Continuity Check protocol	8.5	9.1	9.3
IEEE 802.1ag Ethernet OAM Linktrace protocol	9.0	9.1	9.3
IEEE 802.1ag Ethernet OAM Loopback protocol	9.1	9.1	9.3
Firewall filters	8.5	9.1	9.3
Flexible Ethernet encapsulation	8.5	9.1	9.3

Table 70: Protocols and Applications Supported by the Enhanced Queuing IP Services DPCs (DPCE-R-Q) (continued)

Protocol or Application	First Junos OS Release Supported by DPC Model Number (DPC Name)		
	DPCE-R-Q-4XGE-XFP	DPCE-R-Q-20GE-SFP	DPCE-R-Q-20GE-2XGE
	DPCE-R-Q-40GE-SFP		Enhanced Queuing IP Services Multi-Rate DPC
	Enhanced Queuing IP Services DPC	Enhanced Queuing IP Services DPC	
Graceful Routing Engine Switchover (GRES)	8.5	9.1	9.3
Ingress hierarchical quality of service (HQoS) shaping and scheduling: <ul style="list-style-type: none"> • Group of virtual LANs (VLANs) level • Virtual LAN (VLAN) level • Port level 	9.0	9.1	9.3
Intermediate System-to-Intermediate System (IS-IS)	8.5	9.1	9.3
IPv4	8.5	9.1	9.3
IP multicast	8.5	9.1	9.3
IPv6	8.5	9.1	9.3
IPv6 multicast	8.5	9.1	9.3
IPv6 Neighbor Discovery	8.5	9.1	9.3
Layer 2 frame filtering	8.5	9.1	9.3
IEEE 802.3ad link aggregation	8.5	9.1	9.3
Link Aggregation Control Protocol (LACP)	8.5	9.1	9.3
Local loopback	8.5	9.1	9.3
MAC learning, policing, accounting, and filtering	8.5	9.1	9.3
IEEE 802.1s Multiple Spanning Tree Protocol (MSTP) (part of IEEE 802.1Q VLANs)	8.5	9.1	9.3
Multiple tag protocol identifiers (TPIDs)	8.5	9.1	9.3
Multiprotocol Label Switching (MPLS)	8.5	9.1	9.3

Table 70: Protocols and Applications Supported by the Enhanced Queuing IP Services DPCs (DPCE-R-Q) (continued)

Protocol or Application	First Junos OS Release Supported by DPC Model Number (DPC Name)		
	DPCE-R-Q-4XGE-XFP	DPCE-R-Q-20GE-SFP	DPCE-R-Q-20GE-2XGE
	Enhanced Queuing IP Services DPC	Enhanced Queuing IP Services DPC	Enhanced Queuing IP Services Multi-Rate DPC
IEEE 802.3ah OAM <ul style="list-style-type: none"> Discovery and link monitoring Fault signaling and detection Remote loopback 	8.5	9.1	9.3
Multitopology Routing (MTR)	9.0	9.1	9.3
Open Shortest Path First (OSPF)	8.5	9.1	9.3
Packet mirroring	8.5	9.1	9.3
Quality of service (QoS) per port: <ul style="list-style-type: none"> 8 queues per port Shaping at port level Scheduling of queues based on weighted round-robin (WRR) per priority class Random early detection (RED) Weighted random early detection (WRED) 	8.5	9.1	9.3
Quality of service (QoS) per virtual LAN (VLAN): <ul style="list-style-type: none"> Accounting, filtering, and policing IEEE 802.1p rewrite Classification Tricolor marking Shaping at queue and port level Scheduling of queues based on weighted round-robin (WRR) per priority class Random early detection (RED) Weighted random early detection (WRED) 	8.5	9.1	9.3
Quality of service (QoS) queuing per virtual LAN (VLAN)	8.5	9.1	9.3
IEEE 802.1w Rapid Spanning Tree Protocol (RSTP)	8.5	9.1	9.3
Per-VLAN Spanning Tree (PVST)+	9.0	9.1	9.3

Table 70: Protocols and Applications Supported by the Enhanced Queuing IP Services DPCs (DPCE-R-Q) (continued)

Protocol or Application	First Junos OS Release Supported by DPC Model Number (DPC Name)		
	DPCE-R-Q-4XGE-XFP DPCE-R-Q-40GE-SFP Enhanced Queuing IP Services DPC	DPCE-R-Q-20GE-SFP Enhanced Queuing IP Services DPC	DPCE-R-Q-20GE-2XGE Enhanced Queuing IP Services Multi-Rate DPC
RSVP	8.5	9.1	9.3
Routing Information Protocol (RIP)	8.5	9.1	9.3
SNMP	8.5	9.1	9.3
IEEE 802.1D Spanning Tree Protocol (STP)	8.5	9.1	9.3
Subscriber Management:	9.4	9.4	9.4
• Access Node Control Protocol (ANCP)	9.4	9.4	9.4
• Dynamic profiles	9.2	9.2	9.2
• Dynamic VLANs	9.5	9.5	9.5
• Enhanced Dynamic Host Configuration Protocol (DHCP) local server	9.3	9.3	9.3
• Enhanced DHCP relay	9.3	9.3	9.3
• Firewall filters	9.2	9.2	9.2
• Internet Group Management Protocol (IGMP)	9.2	9.2	9.2
• QoS	9.2	9.2	9.2
• Subscriber Secure Policy	9.4	9.4	9.4
• VLAN demux	–	–	–
Two-Way Active Measurement Protocol (TWAMP)	9.5	9.5	9.5

Table 70: Protocols and Applications Supported by the Enhanced Queuing IP Services DPCs (DPCE-R-Q) (continued)

Protocol or Application	First Junos OS Release Supported by DPC Model Number (DPC Name)		
	DPCE-R-Q-4XGE-XFP DPCE-R-Q-40GE-SFP Enhanced Queuing IP Services DPC	DPCE-R-Q-20GE-SFP Enhanced Queuing IP Services DPC	DPCE-R-Q-20GE-2XGE Enhanced Queuing IP Services Multi-Rate DPC
IEEE 802.1Q VLANs:	8.5	9.1	9.3
<ul style="list-style-type: none"> VLAN stacking and rewriting Channels defined by two stacked VLAN tags Flexible VLAN tagging IP service for nonstandard TPID and stacked VLAN tags 			
Virtual private LAN service (VPLS)	8.5	9.1	9.3
Virtual private network (VPN)	8.5	9.1	9.3
Virtual Router Redundancy Protocol (VRRP) for IPv4	8.5	9.1	9.3

Related Documentation

- [DPCs Supported on MX240, MX480, and MX960 Routers on page 7](#)
- [Protocols and Applications Supported by DPCs and Enhanced DPCs \(DPC and DPCE-R\) on page 297](#)
- [Protocols and Applications Supported by Enhanced Ethernet Services DPCs \(DPCE-X\) on page 303](#)
- [Protocols and Applications Supported by Enhanced Queuing Ethernet Services DPCs \(DPCE-X-Q\) on page 312](#)
- [Protocols and Applications Supported by the Multiservices DPC \(MS-DPC\) on page 317](#)

Protocols and Applications Supported by Enhanced Queuing Ethernet Services DPCs (DPCE-X-Q)

Table 71 on page 313 contains the first Junos OS Release support for protocols and applications on the MX240, MX480, and MX960 Enhanced Queuing Ethernet Services DPCs. A dash indicates that the protocol or application is not supported.

Table 71: Protocols and Applications Supported by the Enhanced Queuing Ethernet Services DPCs (DPCE-X-Q)

Protocol or Application	DPCE-X-Q-4XGE-XFP DPCE-X-Q-40GE-SFP (Enhanced Queuing Ethernet Services DPC)
Access Node Control Protocol (ANCP)	9.4
Accepts traffic destined for GRE tunnels or DVMRP (IP-in-IP) tunnels	8.5
Bidirectional Forwarding Detection protocol (BFD)	8.5
Border Gateway Protocol (BGP)	8.5
BGP/Multiprotocol Label Switching (MPLS) virtual private networks (VPNs)	8.5
Distance Vector Multicast Routing Protocol (DVMRP) and generic routing encapsulation (GRE) support—access side and server side	8.5
IEEE 802.1ag Ethernet OAM Continuity Check protocol	8.5
IEEE 802.1ag Ethernet OAM Linktrace protocol	9.0
IEEE 802.1ag Ethernet OAM Loopback protocol	9.1
Firewall filters	8.5 (Limited filter terms)
Flexible Ethernet encapsulation	8.5
Graceful Routing Engine Switchover (GRES)	8.5
Ingress hierarchical quality of service (HQoS) shaping and scheduling: <ul style="list-style-type: none"> • Group of virtual LANs (VLANs) level • Virtual LAN (VLAN) level • Port level 	9.0
Intermediate System-to-Intermediate System (IS-IS)	8.5
IPv4 (No BGP)	8.5
IP multicast (No BGP)	8.5
IPv6 (No BGP)	8.5

Table 71: Protocols and Applications Supported by the Enhanced Queuing Ethernet Services DPCs (DPCE-X-Q) (*continued*)

Protocol or Application	DPCE-X-Q-4XGE-XFP DPCE-X-Q-40GE-SFP (Enhanced Queuing Ethernet Services DPC)
IPv6 multicast (No BGP)	8.5
IPv6 Neighbor Discovery (No BGP)	8.5
Layer 2 frame filtering	8.5
IEEE 802.3ad link aggregation	8.5
Link Aggregation Control Protocol (LACP)	8.5
Local loopback	8.5
MAC learning, policing, accounting, and filtering	8.5
IEEE 802.1s Multiple Spanning Tree Protocol (MSTP) (part of IEEE 802.1Q VLANs)	8.5
Multiple tag protocol identifiers (TPIDs)	8.5
Multiprotocol Label Switching (MPLS)	8.5
IEEE 802.3ah OAM <ul style="list-style-type: none"> • Discovery and link monitoring • Fault signaling and detection • Remote loopback 	8.5
Multitopology Routing (MTR)	9.0
Open Shortest Path First (OSPF)	8.5
Packet mirroring	8.5
Quality of service (QoS) per port: <ul style="list-style-type: none"> • 8 queues per port • Shaping at port level • Scheduling of queues based on weighted round-robin (WRR) per priority class • Random early detection (RED) • Weighted random early detection (WRED) 	8.5
Shaping at queue level	–

Table 71: Protocols and Applications Supported by the Enhanced Queuing Ethernet Services DPCs (DPCE-X-Q) (continued)

Protocol or Application	DPCE-X-Q-4XGE-XFP DPCE-X-Q-40GE-SFP (Enhanced Queuing Ethernet Services DPC)
Quality of service (QoS) per virtual LAN (VLAN):	8.5
<ul style="list-style-type: none"> • Accounting, filtering, and policing • IEEE 802.1p rewrite • Classification • Tricolor marking • Shaping at port level • Scheduling of queues based on weighted round-robin (WRR) per priority class • Random early detection (RED) • Weighted random early detection (WRED) 	
Shaping at queue level	–
Quality of service (QoS) queuing per virtual LAN (VLAN)	8.5
IEEE 802.1w Rapid Spanning Tree Protocol (RSTP)	8.5
Per-VLAN Spanning Tree (PVST)+	9.0
Remote loopback	8.5
RSVP	8.5
Routing Information Protocol (RIP)	8.5
SNMP	8.5
IEEE 802.1D Spanning Tree Protocol (STP)	8.5
Subscriber Management:	9.4
<ul style="list-style-type: none"> • Access Node Control Protocol (ANCP) 	9.4
<ul style="list-style-type: none"> • Dynamic profiles 	9.2
<ul style="list-style-type: none"> • Dynamic VLANs 	9.5
<ul style="list-style-type: none"> • Enhanced Dynamic Host Configuration Protocol (DHCP) local server 	9.3
<ul style="list-style-type: none"> • Enhanced DHCP relay 	9.3

Table 71: Protocols and Applications Supported by the Enhanced Queuing Ethernet Services DPCs (DPCE-X-Q) (continued)

Protocol or Application	DPCE-X-Q-4XGE-XFP DPCE-X-Q-40GE-SFP (Enhanced Queuing Ethernet Services DPC)
• Firewall filters	9.2
• Internet Group Management Protocol (IGMP)	9.2
• QoS	9.2
• Subscriber Secure Policy	9.4
• VLAN demux	–
Two-Way Active Measurement Protocol (TWAMP)	9.5
IEEE 802.1Q VLANs:	8.5
• VLAN stacking and rewriting	
• Channels defined by two stacked VLAN tags	
• Flexible VLAN tagging	
• IP service for nonstandard TPID and stacked VLAN tags	
Virtual private LAN service (VPLS)	8.5
Virtual private network (VPN)	8.5 (L2 VPN only)
Virtual Router Redundancy Protocol (VRRP) for IPv4	8.5

Related Documentation

- [DPCs Supported on MX240, MX480, and MX960 Routers on page 7](#)
- [Protocols and Applications Supported by DPCs and Enhanced DPCs \(DPC and DPCE-R\) on page 297](#)
- [Protocols and Applications Supported by Enhanced Ethernet Services DPCs \(DPCE-X\) on page 303](#)
- [Protocols and Applications Supported by Enhanced Queuing IP Services DPCs \(DPCE-R-Q\) on page 308](#)
- [Protocols and Applications Supported by the Multiservices DPC \(MS-DPC\) on page 317](#)

Protocols and Applications Supported by the Multiservices DPC (MS-DPC)

Table 72 on page 317 contains the first Junos OS Release support for protocols and applications on the MX240, MX480, and MX960 Multiservices DPCs. A dash indicates that the protocol or application is not supported.



NOTE: The maximum number of supported MS-DPCs is as follows except where noted in Table 72 on page 317:

- MX240 router: 2
- MX480 router: 4
- MX960 router: 6

Table 72: Protocols and Applications Supported by the Multiservices DPC (MS-DPC)

Protocol or Application	MS-DPC
Accepts traffic destined for GRE tunnels	9.3
Active flow monitoring exports cflowd version 5 and version 8 records	9.3
Active flow monitoring exports flow monitoring version 9 records, based on RFC 3954	9.3
Graceful Routing Engine Switchover (GRES)	9.4
GRE dont fragment	9.3
GRE Key	9.3
GRE reassembly	9.3
IP Security (IPSec) encryption	9.3
Network Address Translation (NAT) for IP addresses	9.3
NOTE: The MX960 supports 8 MS-DPCs using this feature.	
NAPT - Preserve parity	15.1
NAPT - Preserve range	15.1
No translation	15.1
Twice NAT	15.1

Table 72: Protocols and Applications Supported by the Multiservices DPC (MS-DPC) (continued)

Protocol or Application	MS-DPC
Packet-triggered dynamic subscribers and policy control (PTSP)	10.2
Port Address Translation (PAT) for port numbers	9.3
Real-time Performance Monitoring (RPM)	9.3
Stateful firewall with packet inspection: detects SYN attacks, ICMP and UDP floods, and ping-of-death attacks	9.3
NOTE: The MX960 supports 8 MS-DPCs using this feature.	
Tunnel services:	
• GRE unicast tunneling-Supports GRE fragmentation	9.3
• IP-IP unicast tunneling	9.4
• Multicast tunneling	9.4
• Protocol Independent Multicast (PIM) sparse mode unicast tunneling	9.4
• Virtual loopback tunneling (VT)	9.4
VLAN demux interfaces	15.1
Voice over IP (VoIP) services:	
• Border Gateway Function (BGF) using external H.248/Ia control	10.2
• Integrated Multi-Service Gateway (IMSG)-Session Border Controller	

Related Documentation

- [DPCs Supported on MX240, MX480, and MX960 Routers on page 7](#)
- [Protocols and Applications Supported by DPCs and Enhanced DPCs \(DPC and DPCE-R\) on page 297](#)
- [Protocols and Applications Supported by Enhanced Ethernet Services DPCs \(DPCE-X\) on page 303](#)
- [Protocols and Applications Supported by Enhanced Queuing IP Services DPCs \(DPCE-R-Q\) on page 308](#)
- [Protocols and Applications Supported by Enhanced Queuing Ethernet Services DPCs \(DPCE-X-Q\) on page 312](#)

CHAPTER 12

MPC Protocol and Application Support for MX240, MX480, MX960, MX2010, and MX2020

- Protocols and Applications Supported by MX240, MX480, MX960, MX2010, and MX2020 MPCs on page 319
- Protocols and Applications Supported by MX240, MX480, MX960, MX2010, and MX2020 MPC1Es on page 328
- Protocols and Applications Supported by MX240, MX480, MX960, MX2010, and MX2020 MPC2E on page 334
- Protocols and Applications Supported by the MX240, MX480, MX960, MX2010, and MX2020 MPC3E on page 343
- Protocols and Applications Supported by the MX240, MX480, MX960, MX2010, and MX2020 MPC4Es on page 351
- Protocols and Applications Supported by the MX240, MX480, MX960, MX2010, and MX2020 MPC5Es on page 358
- Protocols and Applications Supported by the MX2010 and MX2020 MPC6E on page 365
- Protocols and Applications Supported by the MX240, MX480, MX960, MX2010, and MX2020 MPC7Es on page 372
- Protocols and Applications Supported by MPC8E and MPC9E on the MX2010 and MX2020 Routers on page 381
- Protocols and Applications Supported by the MS-MIC and MS-MPC on page 387

Protocols and Applications Supported by MX240, MX480, MX960, MX2010, and MX2020 MPCs

Table 73 on page 320 contains the first Junos OS Release support for protocols and applications on the MX240, MX480, MX960, MX2010, and MX2020 MPCs.



NOTE: The MX2010 router supports protocols and applications in Junos OS 12.3R3 and later. Features added after the Junos OS 12.3R3 release are supported on the MX2010 router in the release indicated.



NOTE: The MX2020 router supports protocols and applications in Junos OS 12.3R2 and later. Features added after the Junos OS 12.3R2 release are supported on the MX2020 router in the release indicated.

A dash indicates that the protocol or application is not supported.

Table 73: Protocols and Applications Supported by the MX240, MX480, MX960, MX2010, and MX2020 MPCs

Protocol or Application	First Junos OS Release Supported by MPC Model Number (MPC Name)					
	MPC-3D-16XGE-SFPP (16x10GE MPC)	MX-MPC1-3D (MPC1)	MX-MPC2-3D (MPC2)	MX-MPC1-3D-Q (MPC1 Q)	MX-MPC2-3D-Q (MPC2 Q)	MX-MPC2-3D-EQ (MPC2EQ)
Access Node Control Protocol (ANCP)	–	10.2	10.2	10.2	10.2	10.2
Accepts traffic destined for GRE tunnels or DVMRP (IP-in-IP) tunnels	10.0R2	10.2	10.1	10.2	10.1	10.1
Active-active bridging in multichassis link aggregation	13.1	13.1	13.1	13.1	13.1	13.1
Bidirectional Forwarding Detection protocol (BFD)	10.0R2	10.2	10.1	10.2	10.1	10.1
Border Gateway Protocol (BGP)	10.0R2	10.2	10.1	10.2	10.1	10.1
BGP/Multiprotocol Label Switching (MPLS) virtual private networks (VPNs)	10.0R2	10.2	10.1	10.2	10.1	10.1
Distance Vector Multicast Routing Protocol (DVMRP) and generic routing encapsulation (GRE) support—access side and server side	10.0R2	10.2	10.1	10.2	10.1	10.1
Distributed denial-of-service (DDoS) protection	11.2	11.2	11.2	11.2		11.2
IEEE 802.1ag Ethernet OAM Continuity Check protocol	10.2 (bridge family supported in 10.4)	10.2 (bridge family supported in 10.4)	10.2 (bridge family supported in 10.4)	10.2 (bridge family supported in 10.4)	10.2 (bridge family supported in 10.4)	10.2 (bridge family supported in 10.4)

Table 73: Protocols and Applications Supported by the MX240, MX480, MX960, MX2010, and MX2020 MPCs (continued)

Protocol or Application	First Junos OS Release Supported by MPC Model Number (MPC Name)					
	MPC-3D-16XGE-SFPP (16x10GE MPC)	MX-MPC1-3D (MPC1)	MX-MPC2-3D (MPC2)	MX-MPC1-3D-Q (MPC1 Q)	MX-MPC2-3D-Q (MPC2 Q)	MX-MPC2-3D-EQ (MPC2 EQ)
IEEE 802.1ag Ethernet OAM Linktrace protocol	10.2 (bridge family supported in 10.4)	10.2 (bridge family supported in 10.4)	10.2 (bridge family supported in 10.4)	10.2 (bridge family supported in 10.4)	10.2 (bridge family supported in 10.4)	10.2 (bridge family supported in 10.4)
IEEE 802.1ag Ethernet OAM Loopback protocol	10.2 (bridge family supported in 10.4)	10.2 (bridge family supported in 10.4)	10.2 (bridge family supported in 10.4)	10.2 (bridge family supported in 10.4)	10.2 (bridge family supported in 10.4)	10.2 (bridge family supported in 10.4)
Firewall filters	10.0R2	10.2	10.1	10.2	10.1	10.1
Flexible Ethernet encapsulation	10.0R2	10.2	10.1	10.2	10.1	10.1
Graceful Routing Engine Switchover (GRES)	10.0R2	10.2	10.1	10.2	10.1	10.1
Ingress Differentiated Services code point (DSCP) rewrite	10.0R2	10.2	10.1	10.2	10.1	10.1
Ingress hierarchical quality-of-service (HQoS) shaping and scheduling: <ul style="list-style-type: none"> • Group of virtual LANs (VLANs) level • Virtual LAN (VLAN) level • Port level 	12.1R3	12.1R3	12.1R3	12.1R3	12.1R3	12.1R3
Intelligent oversubscription	10.0R2	10.2	10.1	10.2	10.1	10.1
Integrated routing and bridging (IRB)	10.1	10.2	10.1	10.2	10.1	10.1
Intermediate System-to-Intermediate System (IS-IS)	10.0R2	10.2	10.1	10.2	10.1	10.1
Internet Group Management Protocol (IGMP) (excluding snooping)	10.0R2	10.2	10.1	10.2	10.1	10.1

Table 73: Protocols and Applications Supported by the MX240, MX480, MX960, MX2010, and MX2020 MPCs (continued)

Protocol or Application	First Junos OS Release Supported by MPC Model Number (MPC Name)					
	MPC-3D-16XGE-SFPP (16x10GE MPC)	MX-MPC1-3D (MPC1)	MX-MPC2-3D (MPC2)	MX-MPC1-3D-Q (MPC1 Q)	MX-MPC2-3D-Q (MPC2 Q)	MX-MPC2-3D-EQ (MPC2EQ)
Internet Group Management Protocol (IGMP) snooping	11.4	11.4	11.4	11.4	11.4	11.4
IPv4	10.0R2	10.2	10.1	10.2	10.1	10.1
IP multicast	10.0R2	10.2	10.1	10.2	10.1	10.1
IPv6	10.2	10.2	10.2	10.2	10.2	10.2
IPv6 MLD	10.2	10.2	10.2	10.2	10.2	10.2
IPv6 multicast	10.2	10.2	10.2	10.2	10.2	10.2
IPv6 Neighbor Discovery	10.2	10.2	10.2	10.2	10.2	10.2
Label Distribution Protocol (LDP)	10.0R2	10.2	10.1	10.2	10.1	10.1
Labeled switched paths (LSPs) including accounting, policers, and filtering	10.0R2	10.2	10.1	10.2	10.1	10.1
LAN-PHY mode	10.0R2	10.2	10.1	10.2	10.1	10.1
Layer 2 frame filtering	10.0R2	10.2	10.1	10.2	10.1	10.1
Layer 2 Tunneling Protocol (L2TP): (MX2010, MX2020: 12.3R4, 13.2R2, 13.3)						
• L2TP access concentrator (LAC)	10.4	10.4	10.4	10.4	10.4	10.4
• L2TP network server (LNS)	11.4	11.4	11.4	11.4	11.4	11.4
• LNS inline service support with CoS per-session shaping	11.4	11.4	11.4	11.4	11.4	11.4
• LNS inline service support without CoS per-session shaping	11.4	11.4	11.4	11.4	11.4	11.4

Table 73: Protocols and Applications Supported by the MX240, MX480, MX960, MX2010, and MX2020 MPCs (*continued*)

Protocol or Application	First Junos OS Release Supported by MPC Model Number (MPC Name)					
	MPC-3D-16XGE-SFPP (16x10GE MPC)	MX-MPC1-3D (MPC1)	MX-MPC2-3D (MPC2)	MX-MPC1-3D-Q (MPC1 Q)	MX-MPC2-3D-Q (MPC2 Q)	MX-MPC2-3D-EQ (MPC2EQ)
• Peer interface	–	11.4	11.4	11.4	11.4	11.4
• Inline IP reassembly	13.1	13.1	13.1	13.1	13.1	13.1
IEEE 802.3ad link aggregation	10.0R2	10.2	10.1	10.2	10.1	10.1
Link Aggregation Control Protocol (LACP)	10.0R2	10.2	10.1	10.2	10.1	10.1
Local loopback	10.0R2	10.2	10.1	10.2	10.1	10.1
MAC learning, policing, accounting, and filtering	10.0R2	10.2	10.1	10.2	10.1	10.1
Mobile IP	–	–	–	–	–	–
<i>Multi-chassis link aggregation</i>	11.1	11.1	11.1	11.1	11.1	11.1
Multiple Tag Protocol Identifiers (TPIDs)	10.0R2	10.2	10.1	10.2	10.1	10.1
Multiprotocol Label Switching (MPLS)	10.0R2	10.2	10.1	10.2	10.1	10.1
Nonstop active routing (NSR)	10.0R2	10.2	10.1	10.2	10.1	10.1
IEEE 802.3ah OAM	11.1	11.1	11.1	11.1	11.1	11.1
• Discovery and link monitoring						
• Fault signaling and detection						
• Remote loopback						
Multitopology routing	10.0R2	10.2	10.1	10.2	10.1	10.1
OSPF	10.0R2	10.2	10.1	10.2	10.1	10.1
Packet mirroring	10.0R2	10.2	10.1	10.2	10.1	10.1
IEEE 802.1ah provider backbone bridges (PBB)	–	–	–	–	–	–

Table 73: Protocols and Applications Supported by the MX240, MX480, MX960, MX2010, and MX2020 MPCs (continued)

Protocol or Application	First Junos OS Release Supported by MPC Model Number (MPC Name)					
	MPC-3D-16XGE-SFPP (16x10GE MPC)	MX-MPC1-3D (MPC1)	MX-MPC2-3D (MPC2)	MX-MPC1-3D-Q (MPC1 Q)	MX-MPC2-3D-Q (MPC2 Q)	MX-MPC2-3D-EQ (MPC2EQ)
Quality of service (QoS) per port:	10.0R2	10.2	10.1	10.2	10.1	10.1
<ul style="list-style-type: none"> • Eight queues per port • Excess-rate configuration at the traffic-control-profile level • Excess-rate and excess-priority configuration at the queue level • Shaping at port level • Shaping at queue level • Scheduling of queues based on weighted round-robin (WRR) per priority class • Tricolor marking • Weighted random early detection (WRED) 						
Quality of service (QoS) per virtual LAN (VLAN):						
<ul style="list-style-type: none"> • Accounting, filtering, and policing 	10.0R2	10.2	10.1	10.2	10.1	10.1
<ul style="list-style-type: none"> • IEEE 802.1p rewrite 	10.0R2	10.2	10.1	10.2	10.1	10.1
<ul style="list-style-type: none"> • Classification 	10.0R2	10.2	10.1	10.2	10.1	10.1
<ul style="list-style-type: none"> • Excess-rate configuration at the traffic-control-profile level 	–	–	–	10.2	10.1	10.1
<ul style="list-style-type: none"> • Excess-rate and excess-priority configuration at the queue level 	–	–	–	10.2	10.1	10.1
<ul style="list-style-type: none"> • Tricolor marking 	10.0R2	10.2	10.1	10.2	10.1	10.1
<ul style="list-style-type: none"> • Shaping at the queue level 	–	–	–	10.2	10.1	10.1
<ul style="list-style-type: none"> • Scheduling of queues based on weighted round-robin (WRR) per priority class 	–	–	–	10.2	10.1	10.1
<ul style="list-style-type: none"> • Weighted random early detection (WRED) 	–	–	–	10.2	10.1	10.1

Table 73: Protocols and Applications Supported by the MX240, MX480, MX960, MX2010, and MX2020 MPCs (continued)

Protocol or Application	First Junos OS Release Supported by MPC Model Number (MPC Name)					
	MPC-3D-16XGE-SFPP (16x10GE MPC)	MX-MPC1-3D (MPC1)	MX-MPC2-3D (MPC2)	MX-MPC1-3D-Q (MPC1 Q)	MX-MPC2-3D-Q (MPC2 Q)	MX-MPC2-3D-EQ (MPC2EQ)
Quality of service (QoS) per Point-to-Point Protocol over Ethernet (PPPoE) or Dynamic Host Configuration Protocol (DHCP) subscriber interfaces:						
• Accounting, filtering, and policing	–	10.2	10.1	10.2	10.1	10.1
• IEEE 802.1p rewrite	–	10.2	10.1	10.2	10.1	10.1
• Classification	–	10.2	10.1	10.2	10.1	10.1
• Excess-rate configuration at the traffic-control-profile level	–	–	–	10.2	10.1	10.1
• Excess-rate and excess-priority configuration at the queue level	–	–	–	10.2	10.1	10.1
• Tricolor marking	–	10.2	10.1	10.2	10.1	10.1
• Shaping at the queue level	–	–	–	10.2	10.1	10.1
• Scheduling of queues based on weighted round-robin (WRR) per priority class	–	–	–	10.2	10.1	10.1
• Weighted random early detection (WRED)	–	–	–	10.2	10.1	10.1
RSVP	10.0R2	10.2	10.1	10.2	10.1	10.1
RIP	10.0R2	10.2	10.1	10.2	10.1	10.1
SNMP	10.0R2	10.2	10.1	10.2	10.1	10.1

Table 73: Protocols and Applications Supported by the MX240, MX480, MX960, MX2010, and MX2020 MPCs (continued)

Protocol or Application	First Junos OS Release Supported by MPC Model Number (MPC Name)					
	MPC-3D-16XGE-SFPP (16x10GE MPC)	MX-MPC1-3D (MPC1)	MX-MPC2-3D (MPC2)	MX-MPC1-3D-Q (MPC1 Q)	MX-MPC2-3D-Q (MPC2 Q)	MX-MPC2-3D-EQ (MPC2EQ)
Spanning Tree Protocols:	10.2	10.2	10.2	10.2	10.2	10.2
<ul style="list-style-type: none"> • IEEE 802.1D Spanning Tree Protocol (STP) • IEEE 802.1s Multiple Spanning Tree Protocol • Per-VLAN Spanning Tree (PVST)+ • IEEE 802.1w Rapid Spanning Tree Protocol (RSTP) 						
Subscriber management and services:						
(MX2010, MX2020: 12.3R4, 13.2R2, 13.3)						
<ul style="list-style-type: none"> • Aggregated Ethernet over static VLANs 	–	10.2	10.1	10.2	10.1	10.1
<ul style="list-style-type: none"> • Aggregated Ethernet over dynamic VLANs 	–	10.2	10.2	10.2	10.2	10.2
Access Node Control Protocol (ANCP) and ANCP agent	–	10.2	10.2	10.2	10.2	10.2
<ul style="list-style-type: none"> • DHCP access model 	–	10.2	10.1	10.2	10.1	10.1
<ul style="list-style-type: none"> • Dynamic adjustment of shapers 	–	10.2	10.1	10.2	10.1	10.1
<ul style="list-style-type: none"> • Dynamic PPPoE subscriber interface creation based on PPPoE service name table configuration 	–	10.2	10.1	10.2	10.1	10.1
<ul style="list-style-type: none"> • Dynamic profiles 	–	10.2	10.1	10.2	10.1	10.1
<ul style="list-style-type: none"> • Dynamic shaping, scheduling, and queuing 	–	10.2	10.1	10.2	10.1	10.1
<ul style="list-style-type: none"> • Dynamic VLANs 	–	10.2	10.2	10.2	10.2	10.2
<ul style="list-style-type: none"> • Static and dynamic PPPoE subscriber interfaces 	–	10.2	10.1	10.2	10.1	10.1

Table 73: Protocols and Applications Supported by the MX240, MX480, MX960, MX2010, and MX2020 MPCs (continued)

Protocol or Application	First Junos OS Release Supported by MPC Model Number (MPC Name)					
	MPC-3D-16XGE-SFPP (16x10GE MPC)	MX-MPC1-3D (MPC1)	MX-MPC2-3D (MPC2)	MX-MPC1-3D-Q (MPC1 Q)	MX-MPC2-3D-Q (MPC2 Q)	MX-MPC2-3D-EQ (MPC2EQ)
Synchronous Ethernet (SyncE)	11.2R4	12.3 with SCBE and later	12.3 with SCBE and later	12.3 with SCBE and later	12.3 with SCBE and later	12.3 with SCBE and later
Tunnel services: <ul style="list-style-type: none"> GRE unicast tunneling-Supports GRE fragmentation IP-IP unicast tunneling Multicast tunneling Protocol Independent Multicast (PIM) sparse mode unicast tunneling Virtual loopback tunneling (VT) 	10.0R2	10.2	10.1	10.2	10.1	10.1
Two-Way Active Measurement Protocol (TWAMP)	10.0R2	10.2	10.1	10.2	10.1	10.1
IEEE 802.1Q VLANs: <ul style="list-style-type: none"> VLAN stacking and rewriting Channels defined by two stacked VLAN tags Flexible VLAN tagging IP service for nonstandard TPID and stacked VLAN tags 	10.0R2	10.2	10.1	10.2	10.1	10.1
Virtual Chassis redundancy	11.2	11.2	11.2	11.2	11.2	11.2
Virtual private LAN service (VPLS)	10.0R2	10.2	10.1	10.2	10.1	10.1
Virtual private network (VPN)	10.0R2	10.2	10.1	10.2	10.1	10.1
Virtual Router Redundancy Protocol (VRRP) for IPv4	10.0R2	10.2	10.1	10.2	10.1	10.1
VRRP over integrated routing and bridging (IRB) on multichassis link aggregation	13.1	13.1	13.1	13.1	13.1	13.1
WAN-PHY mode	–	10.2	10.2	10.2	10.2	10.2

- Related Documentation**
- [MX Series MPC Overview on page 11](#)
 - [MPCs Supported by MX240, MX480, MX960, MX2010, and MX2020 Routers on page 12](#)
 - [ANCP and the ANCP Agent Overview](#)
 - [Understanding BGP](#)
 - [Understanding MPLS Inter-AS Link Protection](#)
 - [IEEE 802.1ag OAM Connectivity Fault Management Overview](#)
 - [Understanding IGMP](#)
 - [Understanding IPv6](#)
 - [Understanding LDP-IGP Synchronization](#)
 - [mc-ae](#)

Protocols and Applications Supported by MX240, MX480, MX960, MX2010, and MX2020 MPC1Es

Table 74 on page 328 contains the first Junos OS Release support for protocols and applications on the MX240, MX480, MX960, MX2010, and MX2020 Enhanced MPCs (MPCEs).



NOTE: The MX2010 and M2020 routers support protocols and applications in Junos OS 12.3 and later. Features added after the Junos OS 12.3 release are supported on the MX2010 and MX2020 routers in the release indicated.

A dash indicates that the protocol or application is not supported.

Table 74: Protocols and Applications Supported by the MX240, MX480, MX960, MX2010, and MX2020 Enhanced MPCs (MPC1Es)

First Junos OS Release Supported by MPC1E Model Number (MPCE Name)		
Protocol or Application	MX-MPC1E-3D (MPC1E)	MX-MPC1E-3D-Q (MPC1E Q)
Access Node Control Protocol (ANCP)	11.2R4	11.2R4
Accepts traffic destined for GRE tunnels or DVMRP (IP-in-IP) tunnels	11.2R4	11.2R4
Bidirectional Forwarding Detection protocol (BFD)	11.2R4	11.2R4
Border Gateway Protocol (BGP)	11.2R4	11.2R4
BGP/Multiprotocol Label Switching (MPLS) virtual private networks (VPNs)	11.2R4	11.2R4

Table 74: Protocols and Applications Supported by the MX240, MX480, MX960, MX2010, and MX2020 Enhanced MPCs (MPC1Es) (*continued*)

First Junos OS Release Supported by MPC1E Model Number (MPC1E Name)		
Protocol or Application	MX-MPC1E-3D (MPC1E)	MX-MPC1E-3D-Q (MPC1E Q)
Distance Vector Multicast Routing Protocol (DVMRP) and generic routing encapsulation (GRE) support—access side and server side	11.2R4	11.2R4
IEEE 802.1ag Ethernet OAM Continuity Check protocol	11.2R4	11.2R4
IEEE 802.1ag Ethernet OAM Linktrace protocol	11.2R4	11.2R4
IEEE 802.1ag Ethernet OAM Loopback protocol	11.2R4	11.2R4
Firewall filters	11.2R4	11.2R4
Flexible Ethernet encapsulation	11.2R4	11.2R4
Graceful Routing Engine Switchover (GRES)	11.2R4	11.2R4
Ingress Differentiated Services code point (DSCP) rewrite	11.2R4	11.2R4
Hierarchical quality-of-service (HQoS)	-	12.1R3
Intelligent oversubscription	11.2R4	11.2R4
Integrated routing and bridging (IRB)	11.2R4	11.2R4
Intermediate System-to-Intermediate System (IS-IS)	11.2R4	11.2R4
Internet Group Management Protocol (IGMP) (excluding snooping)	11.2R4	11.2R4
Internet Group Management Protocol (IGMP) snooping	11.2R4	11.2R4
IPv4	11.2R4	11.2R4
IP multicast	11.2R4	11.2R4
IPv6	11.2R4	11.2R4
IPv6 MLD	11.2R4	11.2R4
IPv6 multicast	11.2R4	11.2R4
IPv6 Neighbor Discovery	11.2R4	11.2R4
Label Distribution Protocol (LDP)	11.2R4	11.2R4

Table 74: Protocols and Applications Supported by the MX240, MX480, MX960, MX2010, and MX2020 Enhanced MPCs (MPC1Es) (continued)

First Junos OS Release Supported by MPC1E Model Number (MPC1E Name)		
Protocol or Application	MX-MPC1E-3D (MPC1E)	MX-MPC1E-3D-Q (MPC1E Q)
Labeled switched paths (LSPs) including accounting, policers, and filtering	11.2R4	11.2R4
LAN-PHY mode	11.2R4	11.2R4
Layer 2 frame filtering	11.2R4	11.2R4
Layer 2 Tunneling Protocol (L2TP):		
• L2TP access concentrator (LAC)	11.3	11.3
• L2TP network server (LNS)	11.4	11.4
• LNS inline service support with CoS per-session shaping	11.4	11.4
• LNS inline service support without CoS per-session shaping	11.4	11.4
• Peer interface	11.4	11.4
• Inline IP Reassembly	13.1	13.1
IEEE 802.3ad link aggregation	11.2R4	11.2R4
Link Aggregation Control Protocol (LACP)	11.2R4	11.2R4
Local loopback	11.2R4	11.2R4
MAC learning, policing, accounting, and filtering	11.2R4	11.2R4
Mobile IP	–	–
<i>Multi-chassis link aggregation</i>	11.2R4	11.2R4
Multiple Tag Protocol Identifiers (TPIDs)	11.2R4	11.2R4
Multiprotocol Label Switching (MPLS)	11.2R4	11.2R4
Nonstop active routing (NSR)	11.2R4	11.2R4
IEEE 802.3ah OAM	11.2R4	11.2R4
• Discovery and link monitoring		
• Fault signaling and detection		
• Remote loopback		

Table 74: Protocols and Applications Supported by the MX240, MX480, MX960, MX2010, and MX2020 Enhanced MPCs (MPC1Es) (*continued*)

First Junos OS Release Supported by MPC1E Model Number (MPCE Name)		
Protocol or Application	MX-MPC1E-3D (MPC1E)	MX-MPC1E-3D-Q (MPC1E Q)
Multitopology routing	11.2R4	11.2R4
OSPF	11.2R4	11.2R4
Packet mirroring	11.2R4	11.2R4
Per-unit scheduling	12.1R3	12.1R3
Precision Time Protocol (PTP) or IEEE 1588v2	12.3	12.3
IEEE 802.1ah provider backbone bridges (PBB)	11.2R4	11.2R4
Quality of service (QoS) per port:	11.2R4	11.2R4
<ul style="list-style-type: none"> • Eight queues per port • Excess-rate configuration at the traffic-control-profile level • Excess-rate and excess-priority configuration at the queue level • Shaping at port level • Shaping at queue level • Scheduling of queues based on weighted round-robin (WRR) per priority class • Tricolor marking • Weighted random early detection (WRED) 		
Quality of service (QoS) per virtual LAN (VLAN):		
<ul style="list-style-type: none"> • Accounting, filtering, and policing 	11.2R4	11.2R4
<ul style="list-style-type: none"> • IEEE 802.1p rewrite 	11.2R4	11.2R4
<ul style="list-style-type: none"> • Classification 	11.2R4	11.2R4
<ul style="list-style-type: none"> • Excess-rate configuration at the traffic-control-profile level 	–	11.2R4
<ul style="list-style-type: none"> • Excess-rate and excess-priority configuration at the queue level 	–	11.2R4
<ul style="list-style-type: none"> • Tricolor marking 	11.2R4	11.2R4
<ul style="list-style-type: none"> • Shaping at the queue level 	–	11.2R4
<ul style="list-style-type: none"> • Scheduling of queues based on weighted round-robin (WRR) per priority class 	–	11.2R4

Table 74: Protocols and Applications Supported by the MX240, MX480, MX960, MX2010, and MX2020 Enhanced MPCs (MPC1Es) (continued)

First Junos OS Release Supported by MPC1E Model Number (MPC1E Name)		
Protocol or Application	MX-MPC1E-3D (MPC1E)	MX-MPC1E-3D-Q (MPC1E Q)
<ul style="list-style-type: none"> Weighted random early detection (WRED) 	–	11.2R4
Quality of service (QoS) per Point-to-Point Protocol over Ethernet (PPPoE) or Dynamic Host Configuration Protocol (DHCP) subscriber interfaces:		
<ul style="list-style-type: none"> Accounting, filtering, and policing 	11.2R4	11.2R4
<ul style="list-style-type: none"> IEEE 802.1p rewrite 	11.2R4	11.2R4
<ul style="list-style-type: none"> Classification 	11.2R4	11.2R4
<ul style="list-style-type: none"> Excess-rate configuration at the traffic-control-profile level 	–	11.2R4
<ul style="list-style-type: none"> Excess-rate and excess-priority configuration at the queue level 	–	11.2R4
<ul style="list-style-type: none"> Tricolor marking 	11.2R4	11.2R4
<ul style="list-style-type: none"> Shaping at the queue level 	–	11.2R4
<ul style="list-style-type: none"> Scheduling of queues based on weighted round-robin (WRR) per priority class 	–	11.2R4
<ul style="list-style-type: none"> Weighted random early detection (WRED) 	–	11.2R4
RSVP	11.2R4	11.2R4
RIP	11.2R4	11.2R4
SNMP	11.2R4	11.2R4
Spanning Tree Protocols:	11.2R4	11.2R4
<ul style="list-style-type: none"> IEEE 802.1D Spanning Tree Protocol (STP) IEEE 802.1s Multiple Spanning Tree Protocol Per-VLAN Spanning Tree (PVST)+ IEEE 802.1w Rapid Spanning Tree Protocol (RSTP) 		
Subscriber Management:		
<ul style="list-style-type: none"> Aggregated Ethernet over static VLANs 	11.2R4	11.2R4
<ul style="list-style-type: none"> Aggregated Ethernet over dynamic VLANs 	11.2R4	11.2R4

Table 74: Protocols and Applications Supported by the MX240, MX480, MX960, MX2010, and MX2020 Enhanced MPCs (MPC1Es) (*continued*)

First Junos OS Release Supported by MPC1E Model Number (MPCE Name)		
Protocol or Application	MX-MPC1E-3D (MPC1E)	MX-MPC1E-3D-Q (MPC1E Q)
• DHCP access model	11.2R4	11.2R4
• Dynamic adjustment of shapers	11.2R4	11.2R4
• Dynamic PPPoE subscriber interface creation based on PPPoE service name table configuration	11.2R4	11.2R4
• Dynamic profiles	11.2R4	11.2R4
• Dynamic shaping, scheduling, and queuing	11.2R4	11.2R4
• Dynamic VLANs	11.2R4	11.2R4
• Static and dynamic PPPoE subscriber interfaces	11.2R4	11.2R4
Synchronous Ethernet (SyncE)	11.2R4	11.2R4
Tunnel services:	11.2R4	11.2R4
<ul style="list-style-type: none"> • GRE unicast tunneling—Supports GRE fragmentation • IP-IP unicast tunneling • Multicast tunneling • Protocol Independent Multicast (PIM) sparse mode unicast tunneling • Virtual loopback tunneling (VT) 		
Two-Way Active Measurement Protocol (TWAMP)	11.2R4	11.2R4
IEEE 802.1Q VLANs:	11.2R4	11.2R4
<ul style="list-style-type: none"> • VLAN stacking and rewriting • Channels defined by two stacked VLAN tags • Flexible VLAN tagging • IP service for nonstandard TPID and stacked VLAN tags 		
Virtual Chassis redundancy	11.2R4	11.2R4
Virtual private LAN service (VPLS)	11.2R4	11.2R4
Virtual private network (VPN)	11.2R4	11.2R4
Virtual Router Redundancy Protocol (VRRP) for IPv4	11.2R4	11.2R4
WAN-PHY mode	11.2R4	11.2R4

- Related Documentation**
- [MX Series MPC Overview on page 11](#)
 - [MPCs Supported by MX240, MX480, MX960, MX2010, and MX2020 Routers on page 12](#)

Protocols and Applications Supported by MX240, MX480, MX960, MX2010, and MX2020 MPC2E

Table 75 on page 334 contains the first Junos OS Release support for protocols and applications on the MX240, MX480, MX960, MX2010, and MX2020 MPC2E.

A dash indicates that the protocol or application is not supported.



NOTE: The MX2010 and M2020 routers support protocols and applications in Junos OS 12.3 and later. Features added after the Junos OS 12.3 release are supported on the MX2010 and MX2020 routers in the release indicated.

A dash indicates that the protocol or application is not supported.

Table 75: Protocols and Applications Supported by the MX240, MX480, MX960, MX2010, and MX2020 MPC2E

Protocol or Application	First Supported Junos OS Release					
	MX-MPC2E-3D (MPC2E)	MX-MPC2E-3D-Q (MPC2E Q)	MX-MPC2E-3D-EQ (MPC2EEQ)	MX-MPC2E-3D-P (MPC2E P)	MX-MPC2E-3D-NG (MPC2E NG)	MX-MPC2E-3D-NG-Q (MPC2E NG-Q)
<i>Access Node Control Protocol (ANCP)</i>	11.2R4	11.2R4	11.2R4	12.2	14.1R4	14.1R4
Accepts traffic destined for generic routing encapsulation (GRE) tunnels or Distance Vector Multicast Routing Protocol (DVMRP) (IP-in-IP) tunnels <ul style="list-style-type: none"> • <i>Dynamic</i> • <i>Manual</i> 	11.2R4	11.2R4	11.2R4	12.2	14.1R4	14.1R4
<i>Bidirectional Forwarding Detection protocol (BFD)</i>	11.2R4	11.2R4	11.2R4	12.2	14.1R4	14.1R4
<i>Border Gateway Protocol (BGP)</i>	11.2R4	11.2R4	11.2R4	12.2	14.1R4	14.1R4
BGP/MPLS virtual private networks (VPNs)	11.2R4	11.2R4	11.2R4	12.2	14.1R4	14.1R4

Table 75: Protocols and Applications Supported by the MX240, MX480, MX960, MX2010, and MX2020 MPC2E (continued)

Protocol or Application	First Supported Junos OS Release					
	MX-MPC2E-3D (MPC2E)	MX-MPC2E-3D-Q (MPC2E Q)	MX-MPC2E-3D-EQ (MPC2EEQ)	MX-MPC2E-3D-P (MPC2E P)	MX-MPC2E-3D-NG (MPC2ENG)	MX-MPC2E-3D-NG-Q (MPC2E NG-Q)
DVMRP and GRE support—access side and server side	11.2R4	11.2R4	11.2R4	12.2	14.1R4	14.1R4
Dynamic Power Management	—	—	—	—	15.1	15.1
Flexible Queuing Mode NOTE: Flexible queuing mode is supported only on non-HQoS variants.	—	—	—	—	15.1	—
IEEE 802.1ag Ethernet OAM Continuity Check protocol	11.2R4	11.2R4	11.2R4	12.2	14.1R4	14.1R4
IEEE 802.1ag Ethernet OAM Linktrace protocol	11.2R4	11.2R4	11.2R4	12.2	14.1R4	14.1R4
IEEE 802.1ag Ethernet OAM Loopback protocol	11.2R4	11.2R4	11.2R4	12.2	14.1R4	14.1R4
Firewall filters	11.2R4	11.2R4	11.2R4	12.2	14.1R4	14.1R4
Flexible Ethernet encapsulation	11.2R4	11.2R4	11.2R4	12.2	14.1R4	14.1R4
Graceful Routing Engine Switchover (GRES)	11.2R4	11.2R4	11.2R4	12.2	14.1R4	14.1R4
Ingress Differentiated Services code point (DSCP) rewrite	11.2R4	11.2R4	11.2R4	12.2	14.1R4	14.1R4

Table 75: Protocols and Applications Supported by the MX240, MX480, MX960, MX2010, and MX2020 MPC2E (continued)

Protocol or Application	First Supported Junos OS Release					
	MX-MPC2E-3D (MPC2E)	MX-MPC2E-3D-Q (MPC2E Q)	MX-MPC2E-3D-EQ (MPC2E EQ)	MX-MPC2E-3D-P (MPC2E P)	MX-MPC2E-3D-NG (MPC2E NG)	MX-MPC2E-3D-NG-Q (MPC2E NG-Q)
Ingress hierarchical quality-of-service (HQoS) shaping and <i>hierarchical-scheduler</i> : <ul style="list-style-type: none"> Group of virtual LANs (VLANs) level Virtual LAN (VLAN) level Port level 	–	–	–	–	15.1R1	15.1R1
Hierarchical quality-of-service (HQoS)	–	12.1R3	12.1R3	–	–	15.1R1
<i>Intelligent Oversubscription on MIC and MPC Interfaces Overview</i>	11.2R4	11.2R4	11.2R4	12.2	14.1R4	14.1R4
<i>Integrated routing and bridging (IRB)</i>	11.2R4	11.2R4	11.2R4	12.2	14.1R4	14.1R4
<i>IS-IS</i>	11.2R4	11.2R4	11.2R4	12.2	14.1R4	14.1R4
Internet Group Management Protocol (IGMP) (excluding snooping)	11.2R4	11.2R4	11.2R4	12.2	14.1R4	14.1R4
Internet Group Management Protocol (IGMP) snooping	11.2R4	11.2R4	11.2R4	12.2	14.1R4	14.1R4
IPv4	11.2R4	11.2R4	11.2R4	12.2	14.1R4	14.1R4
IP multicast	11.2R4	11.2R4	11.2R4	12.2	14.1R4	14.1R4
IPv6	11.2R4	11.2R4	11.2R4	12.2	14.1R4	14.1R4
IPv6 MLD	11.2R4	11.2R4	11.2R4	12.2	14.1R4	14.1R4
IPv6 multicast	11.2R4	11.2R4	11.2R4	12.2	14.1R4	14.1R4
IPv6 Neighbor Discovery	11.2R4	11.2R4	11.2R4	12.2	14.1R4	14.1R4

Table 75: Protocols and Applications Supported by the MX240, MX480, MX960, MX2010, and MX2020 MPC2E (continued)

Protocol or Application	First Supported Junos OS Release					
	MX-MPC2E-3D (MPC2E)	MX-MPC2E-3D-Q (MPC2E Q)	MX-MPC2E-3D-EQ (MPC2E EQ)	MX-MPC2E-3D-P (MPC2E P)	MX-MPC2E-3D-NG (MPC2E NG)	MX-MPC2E-3D-NG-Q (MPC2E NG-Q)
Label Distribution Protocol (LDP)	11.2R4	11.2R4	11.2R4	12.2	14.1R4	14.1R4
<i>Labeled-switched-paths (LSPs)</i> including accounting, policers, and filtering	11.2R4	11.2R4	11.2R4	12.2	14.1R4	14.1R4
LAN-PHY mode	11.2R4	11.2R4	11.2R4	12.2	14.1R4	14.1R4
Layer 2 frame filtering	11.2R4	11.2R4	11.2R4	12.2	14.1R4	14.1R4
Layer 2 Tunneling Protocol (L2TP):					14.1R4	14.1R4
• L2TP access concentrator (LAC)	11.3	11.3	11.3	12.2	14.1R4	14.1R4
• L2TP network server (LNS)	11.4	11.4	11.4	12.2	14.1R4	14.1R4
• LNS inline service support with CoS per-session shaping	11.4	11.4	11.4	12.2	14.1R4	14.1R4
• LNS inline service support without CoS per-session shaping	11.4	11.4	11.4	12.2	14.1R4	14.1R4
• Peer interface	11.4	11.4	11.4	12.2	14.1R4	14.1R4
• Inline IP Reassembly	13.1	13.1	13.1	13.1	14.1R4	14.1R4
<i>Link aggregation (IEEE 802.3ad)</i>	11.2R4	11.2R4	11.2R4	12.2	14.1R4	14.1R4
<i>Link Aggregation Control Protocol (LACP)</i>	11.2R4	11.2R4	11.2R4	12.2	14.1R4	14.1R4
Local loopback	11.2R4	11.2R4	11.2R4	12.2	14.1R4	14.1R4
<i>MAC learning, policing, accounting, and filtering</i>	11.2R4	11.2R4	11.2R4	12.2	14.1R4	14.1R4

Table 75: Protocols and Applications Supported by the MX240, MX480, MX960, MX2010, and MX2020 MPC2E (continued)

Protocol or Application	First Supported Junos OS Release					
	MX-MPC2E-3D (MPC2E)	MX-MPC2E-3D-Q (MPC2E Q)	MX-MPC2E-3D-EQ (MPC2EEQ)	MX-MPC2E-3D-P (MPC2E P)	MX-MPC2E-3D-NG (MPC2ENG)	MX-MPC2E-3D-NG-Q (MPC2E NG-Q)
Mobile IP	–	–	–	–		
<i>Multi-chassis link aggregation</i>	11.2R4	11.2R4	11.2R4	12.2	14.1R4	14.1R4
Multiple Tag Protocol Identifiers (TPIDs)	11.2R4	11.2R4	11.2R4	12.2	14.1R4	14.1R4
Multiprotocol Label Switching (MPLS)	11.2R4	11.2R4	11.2R4	12.2	14.1R4	14.1R4
Nonstop active routing (NSR)	11.2R4	11.2R4	11.2R4	12.2	14.1R4	14.1R4
IEEE 802.3ah OAM <ul style="list-style-type: none"> • Discovery and link monitoring • Fault signaling and detection • Remote loopback 	11.2R4	11.2R4	11.2R4	12.2	14.1R4	14.1R4
Multitopology routing	11.2R4	11.2R4	11.2R4	12.2	14.1R4	14.1R4
OSPF	11.2R4	11.2R4	11.2R4	12.2	14.1R4	14.1R4
Packet mirroring	11.2R4	11.2R4	11.2R4	12.2	14.1R4	14.1R4
Precision Time Protocol (PTP) or IEEE 1588v2	12.3	12.3	12.3	12.2	15.1R2	15.1R2
IEEE 802.1ah provider backbone bridges (PBB)	–	–	–	–	–	–

Table 75: Protocols and Applications Supported by the MX240, MX480, MX960, MX2010, and MX2020 MPC2E (continued)

Protocol or Application	First Supported Junos OS Release					
	MX-MPC2E-3D (MPC2E)	MX-MPC2E-3D-Q (MPC2E Q)	MX-MPC2E-3D-EQ (MPC2EEQ)	MX-MPC2E-3D-P (MPC2E P)	MX-MPC2E-3D-NG (MPC2ENG)	MX-MPC2E-3D-NG-Q (MPC2E NG-Q)
Quality of service (QoS) per port:	11.2R4	11.2R4	11.2R4	12.2	14.1R4	14.1R4
<ul style="list-style-type: none"> • Eight queues per port • Excess-rate configuration at the traffic-control-profile level • Excess-rate and excess-priority configuration at the queue level • Shaping at port level • Shaping at queue level • Scheduling of queues based on weighted round-robin (WRR) per priority class • Tricolor marking • Weighted random early detection (WRED) 						
Quality of service (QoS) per virtual LAN (VLAN):				–	14.1R4	14.1R4
<ul style="list-style-type: none"> • Accounting, filtering, and policing 	11.2R4	11.2R4	11.2R4	12.2	14.1R4	14.1R4
<ul style="list-style-type: none"> • IEEE 802.1p rewrite 	11.2R4	11.2R4	11.2R4	12.2	14.1R4	14.1R4
<ul style="list-style-type: none"> • Classification 	11.2R4	11.2R4	11.2R4	12.2	14.1R4	14.1R4
<ul style="list-style-type: none"> • Excess-rate configuration at the traffic-control-profile level 	–	11.2R4	11.2R4	12.2	14.1R4	14.1R4
<ul style="list-style-type: none"> • Excess-rate and excess-priority configuration at the queue level 	–	11.2R4	11.2R4	12.2	14.1R4	14.1R4
<ul style="list-style-type: none"> • Tricolor marking 	11.2R4	11.2R4	11.2R4	12.2	14.1R4	14.1R4

Table 75: Protocols and Applications Supported by the MX240, MX480, MX960, MX2010, and MX2020 MPC2E (continued)

Protocol or Application	First Supported Junos OS Release					
	MX-MPC2E-3D (MPC2E)	MX-MPC2E-3D-Q (MPC2E Q)	MX-MPC2E-3D-EQ (MPC2EEQ)	MX-MPC2E-3D-P (MPC2E P)	MX-MPC2E-3D-NG (MPC2ENG)	MX-MPC2E-3D-NG-Q (MPC2E NG-Q)
<ul style="list-style-type: none"> Shaping at the queue level 	–	11.2R4	11.2R4	12.2	14.1R4	14.1R4
<ul style="list-style-type: none"> Scheduling of queues based on weighted round-robin (WRR) per priority class 	–	11.2R4	11.2R4	12.2	14.1R4	14.1R4
<ul style="list-style-type: none"> Weighted random early detection (WRED) 	–	11.2R4	11.2R4	12.2	14.1R4	14.1R4
Quality of service (QoS) per Point-to-Point Protocol over Ethernet (PPPoE) or Dynamic Host Configuration Protocol (DHCP) subscriber interfaces:					14.1R4	14.1R4
<ul style="list-style-type: none"> Accounting, filtering, and policing 	11.2R4	11.2R4	11.2R4	12.2	14.1R4	14.1R4
<ul style="list-style-type: none"> IEEE 802.1p rewrite 	11.2R4	11.2R4	11.2R4	12.2	14.1R4	14.1R4
<ul style="list-style-type: none"> Classification 	11.2R4	11.2R4	11.2R4	12.2	14.1R4	14.1R4
<ul style="list-style-type: none"> Excess-rate configuration at the traffic-control-profile level 	–	11.2R4	11.2R4	12.2	14.1R4	14.1R4
<ul style="list-style-type: none"> Excess-rate and excess-priority configuration at the queue level 	–	11.2R4	11.2R4	12.2	14.1R4	14.1R4
<ul style="list-style-type: none"> Tricolor marking 	11.2R4	11.2R4	11.2R4	12.2	14.1R4	14.1R4
<ul style="list-style-type: none"> Shaping at the queue level 	–	11.2R4	11.2R4	12.2	14.1R4	14.1R4
<ul style="list-style-type: none"> Scheduling of queues based on weighted round-robin (WRR) per priority class 	–	11.2R4	11.2R4	12.2	14.1R4	14.1R4

Table 75: Protocols and Applications Supported by the MX240, MX480, MX960, MX2010, and MX2020 MPC2E (continued)

Protocol or Application	First Supported Junos OS Release					
	MX-MPC2E-3D (MPC2E)	MX-MPC2E-3D-Q (MPC2E Q)	MX-MPC2E-3D-EQ (MPC2EEQ)	MX-MPC2E-3D-P (MPC2E P)	MX-MPC2E-3D-NG (MPC2ENG)	MX-MPC2E-3D-NG-Q (MPC2E NG-Q)
<ul style="list-style-type: none"> Weighted random early detection (WRED) 	–	11.2R4	11.2R4	12.2	14.1R4	14.1R4
RSVP	11.2R4	11.2R4	11.2R4	12.2	14.1R4	14.1R4
RIP	11.2R4	11.2R4	11.2R4	12.2	14.1R4	14.1R4
SNMP	11.2R4	11.2R4	11.2R4	12.2	14.1R4	14.1R4
Spanning Tree Protocols: <ul style="list-style-type: none"> IEEE 802.1D Spanning Tree Protocol (STP) IEEE 802.1s Multiple Spanning Tree Protocol Per-VLAN Spanning Tree (PVST)+ IEEE 802.1w Rapid Spanning Tree Protocol (RSTP) 	11.2R4	11.2R4	11.2R4	12.2	14.1R4	14.1R4
Subscriber Management:					14.1R4	14.1R4
<ul style="list-style-type: none"> Aggregated Ethernet over static VLANs 	11.2R4	11.2R4	11.2R4	12.2	14.1R4	14.1R4
<ul style="list-style-type: none"> Aggregated Ethernet over dynamic VLANs 	11.2R4	11.2R4	11.2R4	12.2	14.1R4	14.1R4
<ul style="list-style-type: none"> DHCP access model 	11.2R4	11.2R4	11.2R4	12.2	14.1R4	14.1R4
<ul style="list-style-type: none"> Dynamic adjustment of shapers 	11.2R4	11.2R4	11.2R4	12.2	14.1R4	14.1R4
<ul style="list-style-type: none"> Dynamic PPPoE subscriber interface creation based on PPPoE service name table configuration 	11.2R4	11.2R4	11.2R4	12.2	14.1R4	14.1R4
<ul style="list-style-type: none"> Dynamic profiles 	11.2R4	11.2R4	11.2R4	12.2	14.1R4	14.1R4

Table 75: Protocols and Applications Supported by the MX240, MX480, MX960, MX2010, and MX2020 MPC2E (continued)

Protocol or Application	First Supported Junos OS Release					
	MX-MPC2E-3D (MPC2E)	MX-MPC2E-3D-Q (MPC2E Q)	MX-MPC2E-3D-EQ (MPC2EEQ)	MX-MPC2E-3D-P (MPC2E P)	MX-MPC2E-3D-NG (MPC2ENG)	MX-MPC2E-3D-NG-Q (MPC2E NG-Q)
<ul style="list-style-type: none"> Dynamic shaping, scheduling, and queuing 	11.2R4	11.2R4	11.2R4	12.2	14.1R4	14.1R4
<ul style="list-style-type: none"> Dynamic VLANs 	11.2R4	11.2R4	11.2R4	12.2	14.1R4	14.1R4
<ul style="list-style-type: none"> Static and dynamic PPPoE subscriber interfaces 	11.2R4	11.2R4	11.2R4	12.2	14.1R4	14.1R4
Synchronous Ethernet (SyncE)	11.2R4	11.2R4	11.2R4	12.2	14.1R4	14.1R4
Tunnel services:	11.2R4	11.2R4	11.2R4	12.2	14.1R4	14.1R4
<ul style="list-style-type: none"> GRE unicast tunneling-Supports GRE fragmentation IP-IP unicast tunneling Multicast tunneling Protocol Independent Multicast (PIM) sparse mode unicast tunneling Virtual loopback tunneling (VT) 						
<i>Two-Way Active Measurement Protocol (TWAMP)</i>	11.2R4	11.2R4	11.2R4	12.2	14.1R4	14.1R4
<i>VLANs IEEE 802.1Q</i>	11.2R4	11.2R4	11.2R4	12.2	14.1R4	14.1R4
<ul style="list-style-type: none"> VLAN stacking and rewriting Channels defined by two stacked VLAN tags Flexible VLAN tagging IP service for nonstandard TPID and stacked VLAN tags 						
Virtual Chassis redundancy	11.2R4	11.2R4	11.2R4	12.2	14.1R4	14.1R4

Table 75: Protocols and Applications Supported by the MX240, MX480, MX960, MX2010, and MX2020 MPC2E (continued)

Protocol or Application	First Supported Junos OS Release					
	MX-MPC2E-3D (MPC2E)	MX-MPC2E-3D-Q (MPC2E Q)	MX-MPC2E-3D-EQ (MPC2E EQ)	MX-MPC2E-3D-P (MPC2E P)	MX-MPC2E-3D-NG (MPC2E NG)	MX-MPC2E-3D-NG-Q (MPC2E NG-Q)
Virtual private LAN service (VPLS)	11.2R4	11.2R4	11.2R4	12.2	14.1R4	14.1R4
Virtual private network (VPN)	11.2R4	11.2R4	11.2R4	12.2	14.1R4	14.1R4
Virtual Router Redundancy Protocol (VRRP) for IPv4	11.2R4	11.2R4	11.2R4	12.2	14.1R4	14.1R4
WAN-PHY mode	11.2R4	11.2R4	11.2R4	12.2	14.1R4	14.1R4

Related Documentation

- [MX Series MPC Overview on page 11](#)
- [MPCs Supported by MX240, MX480, MX960, MX2010, and MX2020 Routers on page 12](#)

Protocols and Applications Supported by the MX240, MX480, MX960, MX2010, and MX2020 MPC3E

Table 76 on page 343 contains the first Junos OS Release support for protocols and applications on the MX240, MX480, MX960, MX2010, and MX2020 MPC3E. The protocols and applications support feature parity with Junos OS Release 10.4.



NOTE: The MX2010 and M2020 routers support protocols and applications in Junos OS 12.3 and later. Features added after the Junos OS 12.3 release are supported on the MX2010 and MX2020 routers in the release indicated.

A dash indicates that the protocol or application is not supported.

Table 76: Protocols and Applications Supported by the MX240, MX480, MX960, MX2010, and MX2020 MPC3E

Protocol or Application	First Supported Junos OS Release		
	MPC3E-3D	MPC3E-3D-NG	MPC3E-3D-NG-Q
Access Node Control Protocol (ANCP)	-	14.1R4	14.1R4

Table 76: Protocols and Applications Supported by the MX240, MX480, MX960, MX2010, and MX2020 MPC3E (continued)

Protocol or Application	First Supported Junos OS Release		
	MPC3E-3D	MPC3E-3D-NG	MPC3E-3D-NG-Q
Accepts traffic destined for generic routing encapsulation (GRE) tunnels or Distance Vector Multicast Routing Protocol (DVMRP) (IP-in-IP) tunnels <ul style="list-style-type: none"> • <i>Dynamic</i> • <i>Manual</i> 	12.1	14.1R4	14.1R4
<i>Bidirectional Forwarding Detection protocol (BFD)</i>	12.1	14.1R4	14.1R4
<i>Border Gateway Protocol (BGP)</i>	12.1	14.1R4	14.1R4
Bridge protocol data units (BPDUs)	12.2	14.1R4	14.1R4
BGP/MPLS virtual private networks (VPNs)	12.1	14.1R4	14.1R4
Class of service (CoS): <ul style="list-style-type: none"> • Maintain CoS across internal tunnel interfaces • Packet rewrites • Behavior aggregate (BA) classification • BA classification based on 802.1p of "payload" for core-facing VPLS interfaces • BA DSCP classification of MPLS packets for L3VPN/VPLS LSI and MPLS interfaces • Rate limit option for per-port queues • BA DSCP classification for VPLS/CCC family • Configurable .1p inheritance: push and swap from the hidden tag • Configurable shaping overhead for scheduling 	12.1	14.1R4	14.1R4
Class of service (CoS) per port: <ul style="list-style-type: none"> • Eight queues per port • Excess-rate and excess-priority configurations at the queue level • Shaping at the port level • Shaping at the queue level • Scheduling of queues based on the weighted round-robin (WRR) per excess-priority class • Round-robin scheduling of the queues per priority class • Weighted random early detection (WRED) 	12.1	14.1R4	14.1R4

NOTE: Fine-grained queuing and input queuing are not supported.

Table 76: Protocols and Applications Supported by the MX240, MX480, MX960, MX2010, and MX2020 MPC3E (continued)

Protocol or Application	First Supported Junos OS Release		
	MPC3E-3D	MPC3E-3D-NG	MPC3E-3D-NG-Q
Class of service (CoS) per virtual LAN (VLAN):	12.1	14.1R4	14.1R4
<ul style="list-style-type: none"> Accounting, filtering, and policing IEEE 802.1p rewrite Classification Tricolor marking 			
Class of service (CoS) per Point-to-Point Protocol over Ethernet (PPPoE) or Dynamic Host Configuration Protocol (DHCP) subscriber interfaces:	-	14.1R4	14.1R4
<ul style="list-style-type: none"> Accounting, filtering, and policing IEEE 802.1p rewrite Classification Excess-rate and excess-priority configuration at the queue level Tricolor marking Shaping at the queue level Scheduling of queues based on weighted round-robin (WRR) per priority class Weighted random early detection (WRED) 			
<i>Distributed Denial-of-Service (DDoS) Protection</i>	12.1	14.1R4	14.1R4
<i>DVMRP and GRE support—access side and server side</i>	-	14.1R4	14.1R4
<i>Dynamic Power Management</i>	15.1	15.1	15.1
<i>Ethernet Ring Protection Switching with multiple G.8032 instances</i>	-	14.1R4	14.1R4
<i>Flexible Queuing Mode</i>	15.1	15.1	15.1
NOTE: Flexible queuing mode is supported only on non-HQoS variants.			
<i>IEEE 802.1ag Ethernet OAM Continuity Check protocol</i>	12.2	14.1R4	14.1R4
<i>IEEE 802.1ag Ethernet OAM Linktrace protocol</i>	12.2	14.1R4	14.1R4
<i>IEEE 802.1ag Ethernet OAM Loopback protocol</i>	12.2	14.1R4	14.1R4

Table 76: Protocols and Applications Supported by the MX240, MX480, MX960, MX2010, and MX2020 MPC3E (continued)

Protocol or Application	First Supported Junos OS Release		
	MPC3E-3D	MPC3E-3D-NG	MPC3E-3D-NG-Q
IEEE 802.1ag Maintenance Association Intermediate Point (MIP) support, continuity check message (CCM), stacked VLAN tagging, trunk ports, support for VPLS/VPWS, VLAN circuit cross-connect (CCC) encapsulation and translational cross-connect (TCC) encapsulation	12.2	14.1R4	14.1R4
IEEE 802.1ag Optional type, length, and value (TLVs) support <i>Port Status TLV and Interface Status TLV</i>	-	14.1R4	14.1R4
IEEE 802.3ah distributed periodic packet management (PPM) process, alarm indication signal (AIS), and remote defect indication (RDI)	12.2	14.1R4	14.1R4
<p><i>Firewall filters and policers:</i></p> <ul style="list-style-type: none"> • Policer support for aggregated Ethernet • Aggregate firewall-based policer for all families of a logical interface • Intelligent hierarchial policers <p><i>NOTE:</i> Intelligent hierarchial policers are supported from Junos OS Release 13.3.</p> <ul style="list-style-type: none"> • Set forwarding class and loss priority for Routing Engine-generated packets by using a firewall • Physical interface policers, applying policers to the entire port • Lower policer limit from 32K to 8K • Egress .1p MF and BA classification for VPLS • Differentiated Services Code Point (DSCP) rewrite for IPv4 and IPv6 	12.1	14.1R4	14.1R4
<i>Flexible Ethernet encapsulation</i>	12.1	14.1R4	14.1R4
<i>Graceful Routing Engine Switchover (GRES)</i>	12.1	14.1R4	14.1R4
IGMPv3 support with snooping disabled	12.1	14.1R4	14.1R4
Ingress and egress hierarchical class-of-service (CoS) shaping and <i>hierarchical-scheduler</i> : <ul style="list-style-type: none"> • Group of virtual LANs (VLANs) level • VLAN level • Port level 	-	14.1R4	14.1R4
<i>Inline flow monitoring</i>	12.2	14.1R4	14.1R4

Table 76: Protocols and Applications Supported by the MX240, MX480, MX960, MX2010, and MX2020 MPC3E (continued)

Protocol or Application	First Supported Junos OS Release		
	MPC3E-3D	MPC3E-3D-NG	MPC3E-3D-NG-Q
<i>Intelligent Oversubscription on MIC and MPC Interfaces Overview</i>	12.1	14.1R4	14.1R4
<i>Integrated routing and bridging (IRB)</i>	12.2	14.1R4	14.1R4
<i>Unified In-service software upgrade (Unified ISSU)</i>	13.3	14.1R4	14.1R4
<i>Unified In-service software upgrade (Unified ISSU)</i>	13.3	14.1R4	14.1R4
Interoperability with MPCs and existing DPCs	12.1	14.1R4	14.1R4
Interoperability with Multiservices DPCs	12.2	14.1R4	14.1R4
Interoperability with MX Series Flexible PIC Concentrators (MX-FPC)	-	14.1R4	14.1R4
IPv4	12.1	14.1R4	14.1R4
<i>IPv4 multicast</i>	12.1	14.1R4	14.1R4
<i>IPv6</i>	12.1	14.1R4	14.1R4
IPv6 MLD	12.1	14.1R4	14.1R4
<i>IPv6 multicast</i>	12.1	14.1R4	14.1R4
<i>IPv6 Neighbor Discovery</i>	12.1	14.1R4	14.1R4
<i>IS-IS</i>	12.1	14.1R4	14.1R4
ITU-T Y.1731 timestamping support on MX Series routers	-	14.1R4	14.1R4
Flow monitoring and services:	Release	14.1R4	14.1R4
<ul style="list-style-type: none"> • Active monitoring (multiple v8 version j-flow templates) • Active monitoring (cfloved version 9 templates) • Port mirroring family VPLS, bridge CCC encapsulation (VPWS) • Packet slice for port mirroring • Flow monitoring on Multiservices DPCs • Inline flow monitoring on MPC3E 	<ul style="list-style-type: none"> • 12.2 • 12.2 • 12.2 • 12.2 • - • 12.2 		
		NOTE: Flow monitoring on Multiservices DPCs is not supported.	

Table 76: Protocols and Applications Supported by the MX240, MX480, MX960, MX2010, and MX2020 MPC3E (continued)

Protocol or Application	First Supported Junos OS Release		
	MPC3E-3D	MPC3E-3D-NG	MPC3E-3D-NG-Q
<i>Labeled-switched-paths (LSPs)</i> including accounting, policers, and filtering	12.1	14.1R4	14.1R4
<i>LDP</i>	12.1	14.1R4	14.1R4
Layer 2 features: <ul style="list-style-type: none"> • Trunk ports • Layer 2 support for MX Series Virtual Chassis • Layer 2 and Layer 2.5, IRB and Spanning Tree Protocols (xSTP) • IEEE 802.1ad provider bridges • Layer 2 protocol tunneling (L2PT) support • Layer 2 Tunneling Protocol (L2TP) • Multi-chassis LAG—active/active and active/standby • Multi-chassis LAG—active/active with IGMP snooping • Link aggregation group (LAG)—VLAN-CCC encapsulation • IGMP snooping with bridging, IRB, and VPLS 	Release <ul style="list-style-type: none"> • 12.2 • - • 12.2 • 12.2 • 12.2 • 12.2 • - • - • - • - 	14.1R4	14.1R4
Layer 2 VPN interfaces support VLAN ID list	12.1	14.1R4	14.1R4
<i>Link aggregation (IEEE 802.3ad)</i>	12.1	14.1R4	14.1R4
<i>Link Aggregation Control Protocol (LACP)</i>	12.1	14.1R4	14.1R4
<i>Link Layer Discovery Protocol (LLDP)</i>	-	14.1R4	14.1R4
Local loopback	12.1	14.1R4	14.1R4
<i>MAC learning, policing, accounting, and filtering</i>	12.1	14.1R4	14.1R4
Mobile IP	-	14.1R4	14.1R4
Multichassis link aggregation	-	14.1R4	14.1R4
Multiple Tag Protocol Identifiers (TPIDs)	12.1	14.1R4	14.1R4

NOTE: LAG features and IGMP snooping with bridging, IRB, and VPLS are not supported in 12.2.

Table 76: Protocols and Applications Supported by the MX240, MX480, MX960, MX2010, and MX2020 MPC3E (continued)

Protocol or Application	First Supported Junos OS Release		
	MPC3E-3D	MPC3E-3D-NG	MPC3E-3D-NG-Q
<i>MPLS:</i>	12.1	14.1R4	14.1R4
<ul style="list-style-type: none"> Switching of pseudowire segments (multisegment pseudowires with BGP-L2VPN) LDP signaling for VPLS (LDP-VPLS) and MAC flush message processing (MAC-FLUSH-TLV) RSVP graceful restart interoperability with Cisco using Nodal Hello Failure action on BFD session down of RSVP LSPs OSPF and IS-IS loop-free alternates (LFA) 4/5 label MPLS operation Virtual circuit connectivity verification (VCCV) BFD Point to multipoint using the enhanced-ip command (support for NG-MVPN and P2MP load balancing over aggregated Ethernet) MPLS-FRR bypass link protection Load sharing across 64 ECMP next hops MPLS-FRR VPLS instance prioritization Five label stack on ingress 			
MPLS node protection, link protection, and statistics for static LSPs	12.1	14.1R4	14.1R4
<i>Multiple VLAN Registration Protocol (MVRP)</i>	-	14.1R4	14.1R4
<i>Multitopology routing</i>	12.1	14.1R4	14.1R4
Nonstop active routing (NSR)	12.1	14.1R4	14.1R4
<i>OSPF</i>	12.1	14.1R4	14.1R4
Packet mirroring	12.2	14.1R4	14.1R4
Precision Time Protocol (IEEE 1588)	15.1R2	15.1R2	15.1R2
IEEE 802.1ah provider backbone bridging (PBB)	-	14.1R4	14.1R4
Push a tag on Ethernet VPLS and Ethernet CCC tag encapsulations	-	14.1R4	14.1R4
<i>RSVP</i>	12.1	14.1R4	14.1R4
<i>RIP</i>	12.1	14.1R4	14.1R4
<i>SNMP</i>	12.1	14.1R4	14.1R4

Table 76: Protocols and Applications Supported by the MX240, MX480, MX960, MX2010, and MX2020 MPC3E (continued)

Protocol or Application	First Supported Junos OS Release		
	MPC3E-3D	MPC3E-3D-NG	MPC3E-3D-NG-Q
Spanning Tree Protocols:	12.2	14.1R4	14.1R4
<ul style="list-style-type: none"> • <i>IEEE 802.1s Multiple Spanning Tree Protocol (MSTP)</i> (part of IEEE 802.1Q VLANs) • <i>IEEE 802.1w Rapid Spanning Tree Protocol (RSTP)</i> • <i>IEEE 802.1D Spanning Tree Protocol (STP)</i> • Per-VLAN Spanning Tree (PVST) • Bridge protocol data units (BPDUs) guard and loop guard • STP inter-protocol action profiles and MAC flush (in VPLS multi-homing, flush all MACs when there is a change in the STP interface state due to root protect) 			
Subscriber management and services:	-	14.1R4	14.1R4
(MX2010, MX2020: 12.3R4, 13.2R2, 13.3)			
<ul style="list-style-type: none"> • Aggregated Ethernet over static VLANs • Aggregated Ethernet over dynamic VLANs • <i>Access Node Control Protocol (ANCP) and the ANCP Agent</i> • DHCP access model • Dynamic adjustment of shapers • Dynamic PPPoE subscriber interface creation based on PPPoE service name table configuration • Dynamic profiles • Dynamic shaping, scheduling, and queuing • Dynamic VLANs • Per unit scheduling • Static and dynamic PPPoE subscriber interfaces 			
Synchronous Ethernet	13.2	14.1R4	14.1R4
<i>Two-Way Active Measurement Protocol (TWAMP)</i>	-	14.1R4	14.1R4
Tunnel services	12.1	14.1R4	14.1R4
Unified in-service software upgrade (ISSU)	13.3	14.1R4	14.1R4
Unnumbered Ethernet Interface	12.1	14.1R4	14.1R4
VLANs <i>IEEE 802.1Q</i> :	12.1	14.1R4	14.1R4
<ul style="list-style-type: none"> • VLAN stacking and rewriting • Channels defined by two stacked VLAN tags • Flexible VLAN tagging • IP service for nonstandard TPID and stacked VLAN tags 			

Table 76: Protocols and Applications Supported by the MX240, MX480, MX960, MX2010, and MX2020 MPC3E (continued)

Protocol or Application	First Supported Junos OS Release		
	MPC3E-3D	MPC3E-3D-NG	MPC3E-3D-NG-Q
Virtual Chassis: MPLS IPv4 and IPv6, unicast, multicast forwarding, VPLS, NSR for Layer 3/MPLS services	-	14.1R4	14.1R4
<i>Virtual private LAN service (VPLS):</i> <ul style="list-style-type: none"> • BGP multihoming for inter-AS VPLS • Gigabit Ethernet as core-facing interface • Configurable label block sizes • Hashing L3/L4 fields under Ethernet pseudowire for VPLS encapsulation, CCC encapsulation, and MPLS encapsulation • VPLS flood forwarding table filter (FTF), input FTF • Broadcast, unicast unknown, and multicast (BUM) traffic hashing over LAG 	12.1	14.1R4	14.1R4
Virtual private network (VPN)	12.1	14.1R4	14.1R4
<i>Virtual Router Redundancy Protocol (VRRP) for IPv4</i>	12.1	14.1R4	14.1R4
VPLS packet flooding to the right set of interfaces across mesh groups	-	14.1R4	14.1R4
WAN-PHY mode	12.2	14.1R4	14.1R4

- Related Documentation**
- [MPC3E on page 163](#)
 - [MICs Supported by MX Series Routers on page 17](#)

Protocols and Applications Supported by the MX240, MX480, MX960, MX2010, and MX2020 MPC4Es

[Table 77 on page 352](#) contains the first Junos OS Release support for protocols and applications on the MX Series MPC4E. The protocols and applications support feature parity with Junos OS Release 12.2. A dash indicates that the protocol or application is not supported.

Table 77: Protocols and Applications Supported by the MX Series MPC4E

Protocol or Application	First Supported Junos OS Release
Accepts traffic destined for generic routing encapsulation (GRE) tunnels or Distance Vector Multicast Routing Protocol (DVMRP) (IP-in-IP) tunnels <ul style="list-style-type: none"> • <i>Dynamic</i> • <i>Manual</i> 	12.3R2
<i>Bidirectional Forwarding Detection protocol (BFD)</i>	12.3R2
<i>Border Gateway Protocol (BGP)</i>	12.3R2
Bridge protocol data units (BPDUs)	12.3R2
BGP/MPLS virtual private networks (VPNs)	12.3R2
Class of service (CoS): <ul style="list-style-type: none"> • CoS maintenance across internal tunnel interfaces • Packet rewrites • Behavior aggregate (BA) classification • BA classification based on 802.1p of "payload" for core-facing VPLS interfaces • BA DSCP classification of MPLS packets for L3VPN/VPLS LSI and MPLS interfaces • Rate limit option for per-port queues • BA DSCP classification for VPLS/CCC family • Configurable .1p inheritance: push and swap from the hidden tag • Configurable shaping overhead for scheduling 	12.3R2
Class of service (CoS) per port: <ul style="list-style-type: none"> • Eight queues per port • Excess-rate and excess-priority configuration at the queue level • Shaping at the port level • Shaping at the queue level • Scheduling of queues based on weighted round-robin (WRR) per excess-priority class • Round-robin scheduling of the queues per priority class • Weighted random early detection (WRED) 	12.3R2 NOTE: Fine-grained queuing and input queuing are not supported.
Class of service (CoS) per virtual LAN (VLAN): <ul style="list-style-type: none"> • Accounting, filtering, and policing • IEEE 802.1p rewrite • Classification • Tricolor marking 	12.3R2

Table 77: Protocols and Applications Supported by the MX Series MPC4E (continued)

Protocol or Application	First Supported Junos OS Release
Class of service (CoS) per Point-to-Point Protocol over Ethernet (PPPoE) or Dynamic Host Configuration Protocol (DHCP) subscriber interfaces: <ul style="list-style-type: none"> Accounting, filtering, and policing IEEE 802.1p rewrite Classification Excess-rate and excess-priority configuration at the queue level Tricolor marking Shaping at the queue level Scheduling of queues based on weighted round-robin (WRR) per priority class Weighted random early detection (WRED) 	–
<i>Distributed Denial-of-Service (DDoS) Protection</i>	12.3R2
<i>DVMRP and GRE support—access side and server side</i>	12.3R2
<i>Ethernet Ring Protection Switching with multiple G.8032 instances</i>	12.3R2
<i>IEEE 802.1ag Ethernet OAM Continuity Check protocol</i>	12.3R2
<i>IEEE 802.1ag Ethernet OAM Linktrace protocol</i>	12.3R2
<i>IEEE 802.1ag Ethernet OAM Loopback protocol</i>	12.3R2
IEEE 802.1ag Mapped IP (MIP) support, continuity check message (CCM), stacked VLAN tagging, trunk ports, support for VPLS/VPWS, VLAN circuit cross-connect (CCC) encapsulation, and transition cross-connect (TCC) encapsulation	12.3R2
IEEE 802.1ag Optional Type, Length, and Value (TLVs) support <i>Port Status TLV and Interface Status TLV</i>	–
IEEE 802.3ah distributed periodic packet management (PPM) process, alarm indication signal (AIS), and remote defect indication (RDI)	12.3R2
<i>Firewall filters and policers:</i> <ul style="list-style-type: none"> Policer support for aggregated Ethernet Aggregate firewall-based policer for all families of a logical interface Set forwarding class, loss priority for Routing Engine-generated packets by using a firewall Physical interface policers, applying policer to the entire port Lower policer limit from 32K to 8K Egress .1p MF and BA classification for VPLS Differentiated Services Code Point (DSCP) rewrite for IPv4 and IPv6 	12.3R2
<i>Flexible Ethernet encapsulation</i>	12.3R2
<i>Graceful routing engine switchover (GRES)</i>	12.3R2

Table 77: Protocols and Applications Supported by the MX Series MPC4E (continued)

Protocol or Application	First Supported Junos OS Release
IGMPv3 support with snooping disabled	12.3R2
Ingress and egress hierarchical class-of-service (CoS) shaping and <i>hierarchical-scheduler</i> : <ul style="list-style-type: none"> Group of virtual LANs (VLANs) level VLAN level Port level 	–
<i>Inline flow monitoring</i>	12.3R2
<i>Intelligent Oversubscription on the Trio MPC/MIC Interfaces</i>	12.3R2
<i>Integrated routing bridging (IRB)</i>	12.3R2
Unified <i>In-service software upgrade (Unified ISSU)</i>	13.3
Interoperability with MPCs and existing DPCs	12.3R2
Interoperability with Multiservices DPCs	12.3R2
Interoperability with MX Series Flexible PIC Concentrators (MX-FPC)	12.3R2
Interoperability with Juniper Networks 100-Gigabit Ethernet PIC	12.3R2
Interoperability with MX Series Application Services Modular Line Card (AS-MLC)	12.3R2
IPv4	12.3R2
<i>IPv4 multicast</i>	12.3R2
<i>IPv6</i>	12.3R2
IPv6 MLD	12.3R2
<i>IPv6 multicast</i>	12.3R2
<i>IPv6 Neighbor Discovery</i>	12.3R2
<i>IS-IS</i>	12.3R2
ITU-T Y.1731 timestamping support on MX Series routers	12.3R2

Table 77: Protocols and Applications Supported by the MX Series MPC4E (*continued*)

Protocol or Application	First Supported Junos OS Release
Flow monitoring and services:	Release
<ul style="list-style-type: none"> Active monitoring (multiple v8 version j-flow templates) Active monitoring (cflowed version 9 templates) Port mirroring family VPLS, bridge CCC encapsulation (VPWS) Packet slice for port mirroring Flow monitoring on Multiservices DPCs Inline flow monitoring on MPC4E 	<ul style="list-style-type: none"> 12.3R2 12.3R2 12.3R2 12.3R2 – 12.3R2
<i>Labeled-switched-paths (LSPs)</i> including accounting, policers, and filtering	12.3R2
<i>LDP</i>	12.3R2
Layer 2 features:	Release
<ul style="list-style-type: none"> Trunk ports Layer 2 support for MX-VC Layer 2 and Layer 2.5, IRB and Spanning Tree Protocols (xSTP) IEEE 802.1ad provider bridges Layer 2 Protocol Tunneling (L2PT) support Layer 2 Tunneling Protocol (L2TP) Multichassis LAG—active/active and active/standby Multichassis LAG—active/active with IGMP snooping Link aggregation group (LAG)—VLAN-ccc encapsulation IGMP snooping with bridging, IRB, and VPLS 	<ul style="list-style-type: none"> 12.3R2 12.3R2 – 12.3R2 13.3R1 12.3R2 13.3R1 13.3R1 – –
Layer 2 VPN interfaces support vlan-id list	12.3R2
<i>Link aggregation (IEEE 802.3ad)</i>	12.3R2
<i>Link Aggregation Control Protocol (LACP)</i>	12.3R2
<i>Link Layer Discovery Protocol (LLDP)</i>	–
Local loopback	12.3R2
<i>MAC learning, policing, accounting, and filtering</i>	12.3R2
Mobile IP	–
Multichassis Link Aggregation (MC-LAG)	13.3R1
Multiple Tag Protocol Identifiers (TPIDs)	12.3R2

Table 77: Protocols and Applications Supported by the MX Series MPC4E (continued)

Protocol or Application	First Supported Junos OS Release
<p><i>MPLS:</i></p> <ul style="list-style-type: none"> Switching of pseudowire segments (multisegment pseudowires with BGP-L2VPN) LDP signaling for VPLS (LDP-VPLS) and MAC flush message processing (MAC-FLUSH-TLV) RSVP graceful restart interoperability with Cisco using Nodal Hello Failure action on BFD session down of RSVP LSPs OSPF and IS-IS loop-free alternates (LFA) 4/5 label MPLS operation Virtual circuit connection verification (VCCV) BFD Point to multipoint using the enhanced-ip command (support for NG-MVPN and P2MP load balancing over aggregated Ethernet) MPLS-FRR bypass link protection Load sharing across 64 ECMP next hops MPLS-FRR VPLS instance prioritization Five label stack on ingress 	12.3R2
MPLS node protection, link protection, and statistics for static LSPs	12.3R2
<i>Multiple VLAN Registration Protocol (MVRP)</i>	–
<i>Multitopology routing</i>	–
Nonstop active routing (NSR)	12.3R2
<i>OSPF</i>	12.3R2
Packet mirroring	12.3R2
Precision Time Protocol (IEEE 1588)	15.1R1
IEEE 802.1ah provider backbone bridges (PBB)	–
Push a tag on Ethernet VPLS and Ethernet CCC tag encapsulations	–
<i>RSVP</i>	12.3R2
<i>RIP</i>	12.3R2
<i>SNMP</i>	12.3R2

Table 77: Protocols and Applications Supported by the MX Series MPC4E (*continued*)

Protocol or Application	First Supported Junos OS Release
Spanning Tree Protocols:	12.3R2
<ul style="list-style-type: none"> • <i>IEEE 802.1s Multiple Spanning Tree Protocol (MSTP)</i> (part of IEEE 802.1Q VLANs) • <i>IEEE 802.1w Rapid Spanning Tree Protocol (RSTP)</i> • <i>IEEE 802.1D Spanning Tree Protocol (STP)</i> • Per-VLAN Spanning Tree (PVST) • Bridge protocol data units (BPDUs) guard and loop guard • STP interprotocol action profiles and MAC flush (in VPLS multihoming, flush all MACs when there is a change in the STP interface state due to root protect) 	
Subscriber management and services::	-
(MX2010, MX2020: 12.3R4, 13.2R2, 13.3)	
<ul style="list-style-type: none"> • Aggregated Ethernet over static VLANs • Aggregated Ethernet over dynamic VLANs • <i>Access Node Control Protocol (ANCP) and the ANCP Agent</i> • DHCP access model • Dynamic adjustment of shapers • Dynamic PPPoE subscriber interface creation based on PPPoE service name table configuration • Dynamic profiles • Dynamic shaping, scheduling, and queuing • Dynamic VLANs • Static and dynamic PPPoE subscriber interfaces 	
Synchronous Ethernet (SyncE)	12.3 with SCBE and later
<i>Two-Way Active Measurement Protocol (TWAMP)</i>	-
Tunnel services	12.3R2
Unnumbered Ethernet Interface	12.3R2
VLANs <i>IEEE 802.1Q</i> :	12.3R2
<ul style="list-style-type: none"> • VLAN stacking and rewriting • Channels defined by two stacked VLAN tags • Flexible VLAN tagging • IP service for nonstandard TPID and stacked VLAN tags 	
Virtual chassis: MPLS IPv4 and IPv6, unicast, multicast forwarding, VPLS, NSR for Layer 3 MPLS services	-

Table 77: Protocols and Applications Supported by the MX Series MPC4E (continued)

Protocol or Application	First Supported Junos OS Release
<i>Virtual private LAN service (VPLS):</i> <ul style="list-style-type: none"> BGP multihoming for inter-AS VPLS Gigabit Ethernet as core-facing interface Configurable label block sizes Hashing L3/L4 fields under Ethernet pseudowire for VPLS encapsulation, CCC encapsulation, and MPLS encapsulation VPLS flood forwarding table filter (FTF), input FTF Broadcast, unicast unknown, and multicast (BUM) traffic hashing over LAG 	12.3R2
Virtual private network (VPN)	12.3R2
<i>Virtual Router Redundancy Protocol (VRRP) for IPv4</i>	12.3R2
VPLS packet flooding to the right set of interfaces across mesh groups	12.3R2
WAN-PHY mode	12.3R2

Related Documentation

- [32x10GE MPC4E on page 169](#)
- [2x100GE + 8x10GE MPC4E on page 171](#)
- [MICs Supported by MX Series Routers on page 17](#)
- [MPCs Supported by MX240, MX480, MX960, MX2010, and MX2020 Routers on page 12](#)

Protocols and Applications Supported by the MX240, MX480, MX960, MX2010, and MX2020 MPC5Es

Table 78 on page 358 contains the first Junos OS Release support for protocols and applications in the MPC5E installed on the MX240, MX480, MX960, MX2010, and MX2020 routers. The protocols and applications support feature parity with Junos OS Release 12.3.

A dash indicates that the protocol or application is not supported.

Table 78: Protocols and Applications Supported by the MX240, MX480, MX960, MX2010, and MX2020 MPC5E

Protocol or Application	First Supported Junos OS Release
<i>Access Node Control Protocol (ANCP)</i>	-

Table 78: Protocols and Applications Supported by the MX240, MX480, MX960, MX2010, and MX2020 MPC5E (continued)

Protocol or Application	First Supported Junos OS Release
Accepts traffic destined for generic routing encapsulation (GRE) tunnels or Distance Vector Multicast Routing Protocol (DVMRP) (IP-in-IP) tunnels <ul style="list-style-type: none"> • <i>Dynamic</i> • <i>Manual</i> 	13.3R3
<i>Bidirectional Forwarding Detection protocol (BFD)</i>	13.3R3
<i>Border Gateway Protocol (BGP)</i>	13.3R3
Bridge protocol data units (BPDUs)	13.3R3
BGP/MPLS virtual private networks (VPNs)	13.3R3
Class of service (CoS): <ul style="list-style-type: none"> • Maintain CoS across internal tunnel interfaces • Packet rewrites • Behavior aggregate (BA) classification • BA classification based on 802.1p of <i>payload</i> for core-facing VPLS interfaces • BA DSCP classification of MPLS packets for Layer 3 VPN/VPLS LSI and MPLS interfaces • Rate limit option for per-port queues • BA DSCP classification for VPLS/CCC family • Configurable .1p inheritance: push and swap from the hidden tag • Configurable shaping overhead for scheduling 	13.3R3
Class of service (CoS) per port: <ul style="list-style-type: none"> • Eight queues per port • Excess-rate and excess-priority configurations at the queue level • Shaping at the port level • Shaping at the queue level • Scheduling of queues based on the weighted round-robin (WRR) per excess-priority class • Round-robin scheduling of the queues per priority class • Weighted random early detection (WRED) 	13.3R3
Class of service (CoS) per virtual LAN (VLAN): <ul style="list-style-type: none"> • Accounting, filtering, and policing • IEEE 802.1p rewrite • Classification • Tricolor marking 	13.3R3

Table 78: Protocols and Applications Supported by the MX240, MX480, MX960, MX2010, and MX2020 MPC5E (continued)

Protocol or Application	First Supported Junos OS Release
Class of service (CoS) per Point-to-Point Protocol over Ethernet (PPPoE) or Dynamic Host Configuration Protocol (DHCP) subscriber interfaces: <ul style="list-style-type: none"> • Accounting, filtering, and policing • IEEE 802.1p rewrite • Classification • Excess-rate and excess-priority configuration at the queue level • Tricolor marking • Shaping at the queue level • Scheduling of queues based on weighted round-robin (WRR) per priority class • Weighted random early detection (WRED) 	13.3R3
<i>Distributed Denial-of-Service (DDoS) Protection</i>	13.3R3
<i>DVMRP and GRE support—access side and server side</i>	13.3R3
<i>Ethernet Ring Protection Switching with multiple G.8032 instances</i>	13.3R3
<i>IEEE 802.1ag Ethernet OAM Continuity Check protocol</i>	13.3R3
<i>IEEE 802.1ag Ethernet OAM Linktrace protocol</i>	13.3R3
<i>IEEE 802.1ag Ethernet OAM Loopback protocol</i>	13.3R3
IEEE 802.1ag Maintenance Association Intermediate Point (MIP) support, continuity check message (CCM), stacked VLAN tagging, trunk ports, support for VPLS/VPWS, VLAN circuit cross-connect (CCC) encapsulation and translational cross-connect (TCC) encapsulation	13.3R3
<i>Port Status TLV and Interface Status TLV</i>	-
IEEE 802.3ah distributed periodic packet management (PPM) process, alarm indication signal (AIS), and remote defect indication (RDI)	13.3R3
<i>Firewall filters and policers:</i> <ul style="list-style-type: none"> • Policer support for aggregated Ethernet • Aggregate firewall-based policer for all families of a logical interface • Set forwarding class and loss priority for Routing Engine-generated packets by using a firewall • Physical interface policers, applying policers to the entire port • Lower policer limit from 32,000 to 8000 • Egress .1p MF and BA classification for VPLS • Differentiated Services Code Point (DSCP) rewrite for IPv4 and IPv6 	13.3R3
<i>Flexible Ethernet encapsulation</i>	13.3R3

Table 78: Protocols and Applications Supported by the MX240, MX480, MX960, MX2010, and MX2020 MPC5E (continued)

Protocol or Application	First Supported Junos OS Release
<i>Flexible Queuing Mode</i>	14.1R1
NOTE: Flexible queuing mode is supported only on non-HQoS variants.	
<i>Graceful Routing Engine Switchover (GRES)</i>	13.3R3
IGMPv3 support with snooping disabled	13.3R3
Ingress and egress hierarchical class-of-service (CoS) shaping and <i>hierarchical-scheduler</i> :	13.3R3
<ul style="list-style-type: none"> • Group of virtual LANs (VLANs) level • VLAN level • Port level 	
Hierarchical CoS on generic routing encapsulation (GRE) tunnels	15.1R2
<i>Inline active flow monitoring</i>	13.3R3
<i>Intelligent Oversubscription</i>	13.3R3
<i>Integrated routing and bridging (IRB)</i>	13.3R3
<i>Unified In-service software upgrade (Unified ISSU)</i>	16.1R1
Interoperability with MPCs and existing DPCs	-
Interoperability with Multiservices DPCs	13.3R3
Interoperability with MX Series Flexible PIC Concentrators (MX-FPC)	13.3R3
Interoperability with Juniper Networks 100-Gigabit Ethernet PIC	13.3R3
Interoperability with MX Series Application Services Modular Line Card (AS-MLC)	13.3R3
IPv4	13.3R3
<i>IPv4 multicast</i>	13.3R3
<i>IPv6</i>	13.3R3
IPv6 MLD	13.3R3
<i>IPv6 multicast</i>	13.3R3
<i>IPv6 Neighbor Discovery</i>	13.3R3

Table 78: Protocols and Applications Supported by the MX240, MX480, MX960, MX2010, and MX2020 MPC5E (*continued*)

Protocol or Application	First Supported Junos OS Release
<i>IS-IS</i>	13.3R3
ITU-T Y.1731 timestamping support on MX Series routers	13.3R3
Flow monitoring and services:	Release
<ul style="list-style-type: none"> Active monitoring (multiple version 8 j-flow templates) Active monitoring (cfloved version 9 templates) Port mirroring family VPLS, bridge CCC encapsulation (VPWS) Packet slice for port mirroring Flow monitoring on Multiservices DPCs Inline active flow monitoring on MPC5E 	<ul style="list-style-type: none"> 13.3R3 13.3R3 13.3R3 13.3R3 - 13.3R3
<i>Labeled-switched-paths (LSPs)</i> including accounting, policers, and filtering	13.3R3
<i>LDP</i>	13.3R3
<i>Layer 2 features:</i>	Release
<ul style="list-style-type: none"> Trunk ports Layer 2 support for MX Series Virtual Chassis Layer 2 and Layer 2.5, IRB, and Spanning Tree Protocols (xSTP) IEEE 802.1ad provider bridges Layer 2 protocol tunneling (L2PT) support Layer 2 Tunneling Protocol (L2TP) Multichassis LAG—active/active and active/standby Multichassis LAG—active/active with IGMP snooping Link aggregation group (LAG)—VLAN-CCC encapsulation IGMP snooping with bridging, IRB, and VPLS 	<ul style="list-style-type: none"> 13.3R3 13.3R3 - 13.3R3 13.3R3 13.3R3 13.3R3 13.3R3 13.3R3 13.3R3 13.3R3
Layer 2 VPN interfaces support VLAN ID list	13.3R3
<i>Link aggregation (IEEE 802.3ad)</i>	13.3R3
<i>Link Aggregation Control Protocol (LACP)</i>	13.3R3
<i>Link Layer Discovery Protocol (LLDP)</i>	13.3R3
Local loopback	13.3R3
<i>MAC learning, policing, accounting, and filtering</i>	13.3R3
Mobile IP	-
Multichassis link aggregation	-

Table 78: Protocols and Applications Supported by the MX240, MX480, MX960, MX2010, and MX2020 MPC5E (continued)

Protocol or Application	First Supported Junos OS Release
Multiple Tag Protocol Identifiers (TPIDs)	13.3R3
<i>MPLS:</i> <ul style="list-style-type: none"> • Switching of pseudowire segments (multisegment pseudowires with BGP-L2VPN) • LDP signaling for VPLS (LDP-VPLS) and MAC flush message processing (MAC-FLUSH-TLV) • RSVP graceful restart interoperability with Cisco using Nodal Hello • Failure action on BFD session down of RSVP LSPs • OSPF and IS-IS loop-free alternates (LFA) • 4/5 label MPLS operation • Virtual circuit connectivity verification (VCCV) BFD • <i>Point to multipoint</i> using the enhanced-ip command (support for NG-MVPN and <i>point-to-multipoint</i> load balancing over aggregated Ethernet) • MPLS-FRR bypass link protection • Load sharing across 64 ECMP next hops • MPLS-FRR VPLS instance prioritization • Five label stack on ingress 	13.3R3
MPLS node protection, link protection, and statistics for static LSPs	13.3R3
<i>Multiple VLAN Registration Protocol (MVRP)</i>	-
<i>Multitopology routing</i>	-
Nonstop active routing (NSR)	13.3R3
<i>OSPF</i>	13.3R3
Packet mirroring	13.3R3
Precision Time Protocol (IEEE 1588)	14.2R2
IEEE 802.1ah provider backbone bridging (PBB)	-
Push a tag on Ethernet VPLS and Ethernet CCC tag encapsulations	13.3R3
<i>RSVP</i>	13.3R3
<i>RIP</i>	13.3R3
<i>SNMP</i>	13.3R3

Table 78: Protocols and Applications Supported by the MX240, MX480, MX960, MX2010, and MX2020 MPC5E (continued)

Protocol or Application	First Supported Junos OS Release
Spanning Tree Protocols: <ul style="list-style-type: none"> • <i>IEEE 802.1s Multiple Spanning Tree Protocol (MSTP)</i> (part of IEEE 802.1Q VLANs) • <i>IEEE 802.1w Rapid Spanning Tree Protocol (RSTP)</i> • <i>IEEE 802.1D Spanning Tree Protocol (STP)</i> • Per-VLAN Spanning Tree (PVST) • Bridge protocol data units (BPDUs) guard and loop guard • STP inter-protocol action profiles and MAC flush 	13.3R3
Subscriber management and services: (MX2010, MX2020: 12.3R4, 13.3R2, 13.3) <ul style="list-style-type: none"> • Aggregated Ethernet over static VLANs • Aggregated Ethernet over dynamic VLANs • <i>Access Node Control Protocol (ANCP) and the ANCP Agent</i> • DHCP access model • Dynamic adjustment of shapers • Dynamic PPPoE subscriber interface creation based on PPPoE service name table configuration • Dynamic profiles • Dynamic shaping, scheduling, and queuing • Dynamic VLANs • Static and dynamic PPPoE subscriber interfaces 	13.3R3
Synchronous Ethernet	13.3R3
<i>Two-Way Active Measurement Protocol (TWAMP)</i>	13.3R3
Tunnel services	13.3R3
Unnumbered Ethernet Interface	13.3R3
VLANs <i>IEEE 802.1Q</i> : <ul style="list-style-type: none"> • VLAN stacking and rewriting • Channels defined by two stacked VLAN tags • Flexible VLAN tagging • IP service for nonstandard TPID and stacked VLAN tags 	13.3R3
Virtual Chassis: MPLS IPv4 and IPv6, unicast, multicast forwarding, VPLS, NSR for Layer 3/MPLS services	13.3R3

Table 78: Protocols and Applications Supported by the MX240, MX480, MX960, MX2010, and MX2020 MPC5E (continued)

Protocol or Application	First Supported Junos OS Release
<i>Virtual private LAN service (VPLS):</i> <ul style="list-style-type: none"> BGP multihoming for inter-AS VPLS Gigabit Ethernet as core-facing interface Configurable label block sizes Hashing L3/L4 fields under Ethernet pseudowire for VPLS encapsulation, CCC encapsulation, and MPLS encapsulation VPLS flood forwarding table filter (FTF), input FTF Broadcast, unicast unknown, and multicast traffic hashing over LAG 	13.3R3
Virtual private network (VPN)	13.3R3
<i>Virtual Router Redundancy Protocol (VRRP) for IPv4</i>	13.3R3
VPLS packet flooding to the right set of interfaces across mesh groups	13.3R3
WAN-PHY mode	13.3R3

- Related Documentation**
- [6x40GE + 24x10GE MPC5E on page 173](#)
 - [6x40GE + 24x10GE MPC5EQ on page 175](#)
 - [MICs Supported by MX Series Routers on page 17](#)

Protocols and Applications Supported by the MX2010 and MX2020 MPC6E

Table 79 on page 365 contains the first Junos OS Release support for protocols and applications on the MX2010 and MX2020 MPC6E. The protocols and applications support feature parity with Junos OS Release 13.3.

A dash indicates that the protocol or application is not supported.

Table 79: Protocols and Applications Supported by the MX2010 and MX2020 MPC6E

Protocol or Application	First Supported Junos OS Release
<i>Access Node Control Protocol (ANCP)</i>	-
Accepts traffic destined for generic routing encapsulation (GRE) tunnels or Distance Vector Multicast Routing Protocol (DVMRP) (IP-in-IP) tunnels <ul style="list-style-type: none"> <i>Dynamic</i> <i>Manual</i> 	13.3R3
<i>Bidirectional Forwarding Detection protocol (BFD)</i>	13.3R3

Table 79: Protocols and Applications Supported by the MX2010 and MX2020 MPC6E (continued)

Protocol or Application	First Supported Junos OS Release
Border Gateway Protocol (BGP)	13.3R3
Bridge protocol data units (BPDUs)	13.3R3
BGP/MPLS virtual private networks (VPNs)	13.3R3
Class of service (CoS): <ul style="list-style-type: none"> Maintain CoS across internal tunnel interfaces Packet rewrites Behavior aggregate (BA) classification BA classification based on 802.1p of <i>payload</i> for core-facing VPLS interfaces BA DSCP classification of MPLS packets for L3VPN/VPLS LSI and MPLS interfaces Rate limit option for per-port queues BA DSCP classification for VPLS/CCC family Configurable .1p inheritance: push and swap from the hidden tag Configurable shaping overhead for scheduling 	13.3R3
Class of service (CoS) per port: <ul style="list-style-type: none"> Eight queues per port Excess-rate and excess-priority configurations at the queue level Shaping at the port level Shaping at the queue level Scheduling of queues based on the weighted round-robin (WRR) per excess-priority class Round-robin scheduling of the queues per priority class Weighted random early detection (WRED) 	13.3R2
Class of service (CoS) per virtual LAN (VLAN): <ul style="list-style-type: none"> Accounting, filtering, and policing IEEE 802.1p rewrite Classification Tricolor marking 	13.3R3
Class of service (CoS) per Point-to-Point Protocol over Ethernet (PPPoE) or Dynamic Host Configuration Protocol (DHCP) subscriber interfaces: <ul style="list-style-type: none"> Accounting, filtering, and policing IEEE 802.1p rewrite Classification Excess-rate and excess-priority configuration at the queue level Tricolor marking Shaping at the queue level Scheduling of queues based on weighted round-robin (WRR) per priority class Weighted random early detection (WRED) 	13.3R3

Table 79: Protocols and Applications Supported by the MX2010 and MX2020 MPC6E (continued)

Protocol or Application	First Supported Junos OS Release
<i>Distributed Denial-of-Service (DDoS) Protection</i>	13.3R3
<i>DVMRP and GRE support—access side and server side</i>	13.3R3
<i>Ethernet Ring Protection Switching with multiple G.8032 instances</i>	13.3R3
<i>IEEE 802.1ag Ethernet OAM Continuity Check protocol</i>	13.3R3
<i>IEEE 802.1ag Ethernet OAM Linktrace protocol</i>	13.3R3
<i>IEEE 802.1ag Ethernet OAM Loopback protocol</i>	13.3R3
IEEE 802.1ag Maintenance Association Intermediate Point (MIP) support, continuity check message (CCM), stacked VLAN tagging, trunk ports, support for VPLS/VPWS, VLAN circuit cross-connect (CCC) encapsulation and translational cross-connect (TCC) encapsulation	13.3R3
IEEE 802.1ag optional type, length, and value (TLV) (<i>Port Status TLV and Interface Status TLV</i>)	-
IEEE 802.3ah distributed periodic packet management (PPM) process, alarm indication signal (AIS), and remote defect indication (RDI)	13.3R3
<i>Firewall filters and policers:</i> <ul style="list-style-type: none"> • Policer support for aggregated Ethernet • Aggregate firewall-based policer for all families of a logical interface • Set forwarding class and loss priority for Routing Engine-generated packets by using a firewall • Physical interface policers, applying policers to the entire port • Lower policer limit from 32,000 to 8000 • Egress .1p MF and BA classification for VPLS • Differentiated Services Code Point (DSCP) rewrite for IPv4 and IPv6 	13.3R3
<i>Flexible Ethernet encapsulation</i>	13.3R3
<i>Graceful Routing Engine Switchover (GRES)</i>	13.3R3
IGMPv3 support with snooping disabled	13.3R3
Ingress and egress hierarchical class-of-service (CoS) shaping and <i>hierarchical-scheduler</i> : <ul style="list-style-type: none"> • Group of virtual LANs (VLANs) level • VLAN level • Port level 	13.3R3
<i>Inline active flow monitoring</i>	13.3R3
<i>Intelligent oversubscription on MIC and MPC interfaces</i>	13.3R3

Table 79: Protocols and Applications Supported by the MX2010 and MX2020 MPC6E (*continued*)

Protocol or Application	First Supported Junos OS Release
<i>Integrated routing and bridging (IRB)</i>	13.3R3
<i>Unified In-service software upgrade (Unified ISSU)</i>	16.1R1
Interoperability with MPCs and existing DPCs	13.3R3
Interoperability with Multiservices DPCs	13.3R3
Interoperability with MX Series Flexible PIC Concentrators (MX-FPC)	13.3R3
IPv4	13.3R3
<i>IPv4 multicast</i>	13.3R3
<i>IPv6</i>	13.3R3
IPv6 MLD	13.3R3
<i>IPv6 multicast</i>	13.3R3
<i>IPv6 neighbor discovery</i>	13.3R3
<i>IS-IS</i>	13.3R3
ITU-T Y.1731 timestamping support on MX Series routers	13.3R3
Flow monitoring and services:	Release
<ul style="list-style-type: none"> • Active monitoring (multiple v8 version j-flow templates) • Active monitoring (cflowed version 9 templates) • Port mirroring family VPLS, bridge CCC encapsulation (VPWS) • Packet slice for port mirroring • Flow monitoring on Multiservices DPCs • Inline active flow monitoring on MPC5E 	<ul style="list-style-type: none"> • 13.3R3 • 13.3R3 • 13.3R3 • 13.3R3 • - • 13.3R3
<i>Labeled-switched-paths (LSPs)</i> including accounting, policers, and filtering	13.3R3
<i>LDP</i>	13.3R3

Table 79: Protocols and Applications Supported by the MX2010 and MX2020 MPC6E (continued)

Protocol or Application	First Supported Junos OS Release
<i>Layer 2 features:</i>	Release
<ul style="list-style-type: none"> • Trunk ports • Layer 2 support for MX Series Virtual Chassis • Layer 2 and Layer 2.5, IRB and Spanning Tree Protocols (xSTP) • IEEE 802.1ad provider bridges • Layer 2 protocol tunneling (L2PT) support • Layer 2 Tunneling Protocol (L2TP) • Multichassis LAG—active/active and active/standby • Multichassis LAG—active/active with IGMP snooping • Link aggregation group (LAG)—VLAN-CCC encapsulation • IGMP snooping with bridging, IRB, and VPLS 	<ul style="list-style-type: none"> • 13.3R3 • 13.3R3 • 15.1R2 • 13.3R3 • 13.3R3 • 13.3R3 • 13.3R3 • 13.3R3 • 15.1R2 • 13.3R2
Layer 2 VPN interfaces	
<i>Link aggregation (IEEE 802.3ad)</i>	13.3R3
<i>Link Aggregation Control Protocol (LACP)</i>	13.3R3
<i>Link Layer Discovery Protocol (LLDP)</i>	-
Local loopback	13.3R3
<i>MAC learning, policing, accounting, and filtering</i>	13.3R3
Mobile IP	-
Multichassis link aggregation	-
Multiple Tag Protocol Identifiers (TPIDs)	13.3R3
<i>MPLS:</i>	13.3R3
<ul style="list-style-type: none"> • Switching of pseudowire segments (multisegment pseudowires with BGP-L2VPN) • LDP signaling for VPLS (LDP-VPLS) and MAC flush message processing (MAC-FLUSH-TLV) • RSVP graceful restart interoperability with Cisco using Nodal Hello • Failure action on BFD session down of RSVP LSPs • OSPF and IS-IS loop-free alternates (LFA) • 4/5 label MPLS operation • Virtual circuit connectivity verification (VCCV) BFD • Point to multipoint using the enhanced-ip command (support for NG-MVPN and P2MP load balancing over aggregated Ethernet) • MPLS-FRR bypass link protection • Load sharing across 64 ECMP next hops • MPLS-FRR VPLS instance prioritization • Five label stack on ingress 	

Table 79: Protocols and Applications Supported by the MX2010 and MX2020 MPC6E (*continued*)

Protocol or Application	First Supported Junos OS Release
MPLS node protection, link protection, and statistics for static LSPs	13.3R3
<i>Multiple VLAN Registration Protocol (MVRP)</i>	-
<i>Multitopology routing</i>	-
Nonstop active routing (NSR)	-
<i>OSPF</i>	13.3R3
Packet mirroring	13.3R3
Precision Time Protocol (IEEE 1588)	-
IEEE 802.1ah provider backbone bridging (PBB)	-
Push a tag on Ethernet VPLS and Ethernet CCC tag encapsulations	13.3R3
<i>RSVP</i>	13.3R3
<i>RIP</i>	13.3R3
<i>SNMP</i>	13.3R3
Spanning Tree Protocols:	13.3R3
<ul style="list-style-type: none"> • <i>IEEE 802.1s Multiple Spanning Tree Protocol (MSTP)</i> (part of IEEE 802.1Q VLANs) • <i>IEEE 802.1w Rapid Spanning Tree Protocol (RSTP)</i> • <i>IEEE 802.1D Spanning Tree Protocol (STP)</i> • Per-VLAN Spanning Tree (PVST) • Bridge protocol data units (BPDUs) guard and loop guard • STP inter-protocol action profiles and MAC flush 	

Table 79: Protocols and Applications Supported by the MX2010 and MX2020 MPC6E (continued)

Protocol or Application	First Supported Junos OS Release
<i>Subscriber management and services:</i> (MX2010, MX2020: 12.3R4, 13.3R2, 13.3) <ul style="list-style-type: none"> • Aggregated Ethernet over static VLANs • Aggregated Ethernet over dynamic VLANs • <i>Access Node Control Protocol (ANCP) and the ANCP Agent</i> • DHCP access model • Dynamic adjustment of shapers • Dynamic PPPoE subscriber interface creation based on PPPoE service name table configuration • Dynamic profiles • Dynamic shaping, scheduling, and queuing • Dynamic VLANs • Static and dynamic PPPoE subscriber interfaces 	13.3R3
Synchronous Ethernet	13.3R3
<i>Two-Way Active Measurement Protocol (TWAMP)</i>	13.3R3
Tunnel services	13.3R3
Unnumbered Ethernet Interface	13.3R3
<i>VLANs IEEE 802.1Q:</i> <ul style="list-style-type: none"> • VLAN stacking and rewriting • Channels defined by two stacked VLAN tags • Flexible VLAN tagging • IP service for nonstandard TPID and stacked VLAN tags 	13.3R3
<i>Virtual private LAN service (VPLS):</i> <ul style="list-style-type: none"> • BGP multihoming for inter-AS VPLS • Gigabit Ethernet as core-facing interface • Configurable label block sizes • Hashing L3/L4 fields under Ethernet pseudowire for VPLS encapsulation, CCC encapsulation, and MPLS encapsulation • VPLS flood forwarding table filter (FTF), input FTF • Broadcast, unknown unicast, and multicast traffic hashing over LAG 	13.3R3
Virtual private network (VPN)	13.3R3
<i>Virtual Router Redundancy Protocol (VRRP) for IPv4</i>	13.3R3
VPLS packet flooding to the right set of interfaces across mesh groups	13.3R3
WAN-PHY mode	13.3R3

- Related Documentation**
- [MPC6E on page 181](#)
 - [MICs Supported by MX Series Routers on page 17](#)

Protocols and Applications Supported by the MX240, MX480, MX960, MX2010, and MX2020 MPC7Es

Table 76 on page 343 contains the first Junos OS Release support for protocols and applications on the MX240, MX480, MX960, MX2010, and MX2020 MPC7Es (“MPC7E 10G” on page 185 and “MPC7E (Multi-Rate)” on page 182). The protocols and applications support feature parity with Junos OS Release 15.1R1.

A dash indicates that the protocol or application is not supported.

Table 80: Protocols and Applications Supported by MPC7Es in the MX240, MX480, MX960, MX2010, and MX2020 Routers

Protocol or Application	First Supported Junos OS Release for MPC7E-MRATE	First Supported Junos OS Release for MPC7E-10G
<i>Access Node Control Protocol (ANCP)</i>	-	-
Accepts traffic destined for generic routing encapsulation (GRE) tunnels or Distance Vector Multicast Routing Protocol (DVMRP) (IP-in-IP) tunnels <ul style="list-style-type: none"> • <i>Dynamic</i> • <i>Manual</i> 	15.1F4	15.1F5
<i>Bidirectional Forwarding Detection protocol (BFD)</i>	15.1F4	15.1F5
<i>Border Gateway Protocol (BGP)</i>	15.1F4	15.1F5
Bridge protocol data units (BPDUs)	15.1F4	15.1F5
BGP/MPLS virtual private networks (VPNs)	15.1F4	15.1F5

Table 80: Protocols and Applications Supported by MPC7Es in the MX240, MX480, MX960, MX2010, and MX2020 Routers (continued)

Protocol or Application	First Supported Junos OS Release for MPC7E-MRATE	First Supported Junos OS Release for MPC7E-10G
Class of service (CoS): <ul style="list-style-type: none"> Maintain CoS across internal tunnel interfaces Packet rewrites Behavior aggregate (BA) classification BA classification based on 802.1p of payload for core-facing VPLS interfaces BA DSCP classification of MPLS packets for L3VPN/VPLS LSI and MPLS interfaces Rate limit option for per-port queues BA DSCP classification for VPLS/CCC family Configurable .1p inheritance: push and swap from the hidden tag Configurable shaping overhead for scheduling 	15.1F4	15.1F5
Class of service (CoS) per port: <ul style="list-style-type: none"> Eight queues per port Excess-rate and excess-priority configurations at the queue level Shaping at the port level Shaping at the queue level Scheduling of queues based on the weighted round-robin (WRR) per excess-priority class Round-robin scheduling of the queues per priority class Weighted random early detection (WRED) 	15.1F4 <i>NOTE:</i> MPC7E-MRATE MPC supports 5 guaranteed and 4 excess priorities.	15.1F5 <i>NOTE:</i> MPC7E-10G MPC supports 5 guaranteed and 4 excess priorities.
Class of service (CoS) per virtual LAN (VLAN): <ul style="list-style-type: none"> Accounting, filtering, and policing IEEE 802.1p rewrite Classification Tricolor marking 	15.1F4	15.1F5

Table 80: Protocols and Applications Supported by MPC7Es in the MX240, MX480, MX960, MX2010, and MX2020 Routers (continued)

Protocol or Application	First Supported Junos OS Release for MPC7E-MRATE	First Supported Junos OS Release for MPC7E-10G
Class of service (CoS) per Point-to-Point Protocol over Ethernet (PPPoE) or Dynamic Host Configuration Protocol (DHCP) subscriber interfaces: <ul style="list-style-type: none"> Accounting, filtering, and policing IEEE 802.1p rewrite Classification Excess-rate and excess-priority configuration at the queue level Tricolor marking Shaping at the queue level Scheduling of queues based on weighted round-robin (WRR) per priority class Weighted random early detection (WRED) 	-	-
<i>Distributed Denial-of-Service (DDoS) Protection</i>	15.1F4	15.1F5
<i>DVMRP and GRE support—access side and server side</i>	-	-
<i>Dynamic Power Management</i>	15.1F4	15.1F5
<i>Ethernet Ring Protection Switching with multiple G.8032 instances</i>	-	-
<i>Flexible Queuing Mode</i>	15.1F4	15.1F5
<i>IEEE 802.1ag Ethernet OAM Continuity Check protocol</i>	15.1F4	15.1F5
<i>IEEE 802.1ag Ethernet OAM Linktrace protocol</i>	15.1F4	15.1F5
<i>IEEE 802.1ag Ethernet OAM Loopback protocol</i>	15.1F4	15.1F5
IEEE 802.1ag maintenance association intermediate point (MIP) support, continuity check message (CCM), stacked VLAN tagging, trunk ports, support for VPLS/VPWS, VLAN circuit cross-connect (CCC) encapsulation and translational cross-connect (TCC) encapsulation	15.1F4	15.1F5

Table 80: Protocols and Applications Supported by MPC7Es in the MX240, MX480, MX960, MX2010, and MX2020 Routers (*continued*)

Protocol or Application	First Supported Junos OS Release for MPC7E-MRATE	First Supported Junos OS Release for MPC7E-10G
IEEE 802.1ag optional type, length, and value (TLVs) support <i>Port Status TLV</i> and <i>Interface Status TLV</i>	-	-
IEEE 802.3ah distributed periodic packet management (PPM) process, alarm indication signal (AIS), and remote defect indication (RDI)	15.1F4	15.1F5
<p><i>Firewall filters and policers:</i></p> <ul style="list-style-type: none"> • Policer support for aggregated Ethernet • Aggregate firewall-based policer for all families of a logical interface • Intelligent hierarchical policers • Set forwarding class and loss priority for Routing Engine-generated packets by using a firewall • Physical interface policers, applying policers to the entire port • Lower policer limit from 32K to 8K • Egress .1p MF and BA classification for VPLS • Differentiated Services Code Point (DSCP) rewrite for IPv4 and IPv6 	<p>15.1F4</p> <p>NOTE: Layer 2 overhead adjustment (packet length used for the policer included in the Layer 2 header) is not supported in 15.1F4.</p>	<p>15.1F5</p> <p>NOTE: Layer 2 overhead adjustment (packet length used for the policer included in the Layer 2 header) is not supported in 15.1F5.</p>
<i>Flexible Ethernet encapsulation</i>	15.1F4	15.1F5
<i>Graceful Routing Engine Switchover (GRES)</i>	15.1F4	15.1F5
IGMPv3 support with snooping disabled	15.1F4	15.1F5
<p>Ingress and egress hierarchical class-of-service (CoS) shaping and <i>hierarchical-scheduler:</i></p> <ul style="list-style-type: none"> • Group of virtual LANs (VLANs) level • VLAN level • Port level 	15.1F4	15.1F5
<i>Inline flow monitoring</i>	15.1F4	15.1F5
<i>Intelligent Oversubscription on MIC and MPC Interfaces Overview</i>	15.1F4	15.1F5
<i>Integrated routing and bridging (IRB)</i>	15.1F4	15.1F5

Table 80: Protocols and Applications Supported by MPC7Es in the MX240, MX480, MX960, MX2010, and MX2020 Routers (continued)

Protocol or Application	First Supported Junos OS Release for MPC7E-MRATE	First Supported Junos OS Release for MPC7E-10G
Unified <i>In-service software upgrade</i> (Unified ISSU)	-	-
Interoperability with MPCs	15.1F4	15.1F5
Interoperability with MS-DPCs	-	-
Interoperability with MX Series Flexible PIC Concentrators (MX-FPC)	-	-
IPv4	15.1F4	15.1F5
<i>IPv4 multicast</i>	15.1F4	15.1F5
<i>IPv6</i>	15.1F4	15.1F5
IPv6 MLD	15.1F4	15.1F5
<i>IPv6 multicast</i>	15.1F4	15.1F5
<i>IPv6 Neighbor Discovery</i>	15.1F4	15.1F5
<i>IS-IS</i>	15.1F4	15.1F5
ITU-T Y.1731 timestamping support on MX Series routers	-	-
Flow monitoring and services	First Supported Junos OS Release for MPC7E-MRATE	First Supported Junos OS Release for MPC7E-10G
Inline IP Flow Information Export (IPFIX)	15.1F4	15.1F5
Active monitoring	15.1F4	15.1F5
Port mirroring family VPLS, bridge CCC encapsulation (VPWS)	15.1F4	15.1F5
Packet slice for port mirroring	15.1F4	15.1F5
Flow monitoring on MS-MPCs	-	-
Inline flow monitoring	15.1F4	15.1F5
<i>Labeled-switched-paths (LSPs) including accounting, policers, and filtering</i>	15.1F4	15.1F5

Table 80: Protocols and Applications Supported by MPC7Es in the MX240, MX480, MX960, MX2010, and MX2020 Routers (*continued*)

Protocol or Application	First Supported Junos OS Release for MPC7E-MRATE	First Supported Junos OS Release for MPC7E-10G
<i>LDP</i>	15.1F4	15.1F5
Layer 2 Features	First Supported Junos OS Release for MPC7E-MRATE	First Supported Junos OS Release for MPC7E-10G
Trunk ports	15.1F4	15.1F5
Layer 2 support for MX Series Virtual Chassis	-	-
Layer 2 and Layer 2.5, IRB and Spanning Tree Protocols (xSTP)	15.1F4	15.1F5
IEEE 802.1ad provider bridges	15.1F4	15.1F5
Layer 2 protocol tunneling (L2PT) support	15.1F4	15.1F5
Layer 2 Tunneling Protocol (L2TP)	15.1F4	15.1F5
Multichassis LAG—active/active and active/standby	-	-
Multichassis LAG—active/active with IGMP snooping	-	-
Link aggregation group (LAG)—VLAN-CCC encapsulation	-	-
IGMP snooping with bridging, IRB, and VPLS	-	-
Layer 2 VPN interfaces support VLAN ID list	15.1F4	15.1F5
<i>Link aggregation (IEEE 802.3ad)</i>	15.1F4	15.1F5
<i>Link Aggregation Control Protocol (LACP)</i>	15.1F4	15.1F5
<i>Link Layer Discovery Protocol (LLDP)</i>	15.1F4	15.1F5
Local loopback	15.1F4	15.1F5
<i>MAC learning, policing, accounting, and filtering</i>	15.1F4	15.1F5
Mobile IP	-	-
Multichassis link aggregation	15.1F4	15.1F5
Multiple Tag Protocol Identifiers (TPIDs)	15.1F4	15.1F5

Table 80: Protocols and Applications Supported by MPC7Es in the MX240, MX480, MX960, MX2010, and MX2020 Routers (continued)

Protocol or Application	First Supported Junos OS Release for MPC7E-MRATE	First Supported Junos OS Release for MPC7E-10G
<i>MPLS:</i>	15.1F4	15.1F5
<ul style="list-style-type: none"> • Switching of pseudowire segments (multisegment pseudowires with BGP-L2VPN) • LDP signaling for VPLS (LDP-VPLS) and MAC flush message processing (MAC-FLUSH-TLV) • RSVP graceful restart interoperability with Cisco using Nodal Hello • Failure action on BFD session down of RSVP LSPs • OSPF and IS-IS loop-free alternates (LFA) • 4/5 label MPLS operation • Virtual circuit connectivity verification (VCCV) BFD • Point to multipoint using the enhanced-ip command (support for NG-MVPN and P2MP load balancing over aggregated Ethernet) • MPLS-FRR bypass link protection • Load sharing across 64 ECMP next hops • MPLS-FRR VPLS instance prioritization • Five label stack on ingress 		
MPLS node protection, link protection, and statistics for static LSPs	15.1F4	15.1F5
<i>Multiple VLAN Registration Protocol (MVRP)</i>	15.1F4	15.1F5
<i>Multitopology routing</i>	15.1F4	15.1F5
Nonstop active routing (NSR)	15.1F4	15.1F5
<i>OSPF</i>	15.1F4	15.1F5
Packet mirroring	15.1F4	15.1F5
Precision Time Protocol (IEEE 1588)	-	-
IEEE 802.1ah provider backbone bridging (PBB)	-	-
Push a tag on Ethernet VPLS and Ethernet CCC tag encapsulations	15.1F4	15.1F5

Table 80: Protocols and Applications Supported by MPC7Es in the MX240, MX480, MX960, MX2010, and MX2020 Routers (*continued*)

Protocol or Application	First Supported Junos OS Release for MPC7E-MRATE	First Supported Junos OS Release for MPC7E-10G
<i>RSVP</i>	15.1F4	15.1F5
<i>RIP</i>	15.1F4	15.1F5
<i>SNMP</i>	15.1F4	15.1F5
Spanning Tree Protocols:	15.1F4	15.1F5
<ul style="list-style-type: none"> • <i>IEEE 802.1s Multiple Spanning Tree Protocol (MSTP)</i> (part of IEEE 802.1Q VLANs) • <i>IEEE 802.1w Rapid Spanning Tree Protocol (RSTP)</i> • <i>IEEE 802.1D Spanning Tree Protocol (STP)</i> • Per-VLAN Spanning Tree (PVST) • Bridge protocol data units (BPDUs) guard and loop guard • STP inter-protocol action profiles and MAC flush (in VPLS multi-homing, flush all MACs when there is a change in the STP interface state due to root protect) 		
<i>Subscriber management and services::</i>	-	-
<ul style="list-style-type: none"> • Aggregated Ethernet over static VLANs • Aggregated Ethernet over dynamic VLANs • <i>Access Node Control Protocol (ANCP) and the ANCP Agent</i> • DHCP access model • Dynamic adjustment of shapers • Dynamic PPPoE subscriber interface creation based on PPPoE service name table configuration • Dynamic profiles • Dynamic shaping, scheduling, and queuing • Dynamic VLANs • Per unit scheduling • Static and dynamic PPPoE subscriber interfaces 		
Synchronous Ethernet	16.1R1	16.1R1
<i>Two-Way Active Measurement Protocol (TWAMP)</i>	-	-

Table 80: Protocols and Applications Supported by MPC7Es in the MX240, MX480, MX960, MX2010, and MX2020 Routers (continued)

Protocol or Application	First Supported Junos OS Release for MPC7E-MRATE	First Supported Junos OS Release for MPC7E-10G
Tunnel services	15.1F4	15.1F5
Unified in-service software upgrade (ISSU)	-	-
Unnumbered Ethernet Interface	15.1F4	15.1F5
<i>VLANs IEEE 802.1Q:</i>	15.1F4	15.1F5
<ul style="list-style-type: none"> VLAN stacking and rewriting Flexible VLAN tagging IP service for nonstandard TPID and stacked VLAN tags 		
Virtual Chassis: MPLS IPv4 and IPv6, unicast, multicast forwarding, VPLS, NSR for Layer 3/MPLS services	-	-
<i>Virtual private LAN service (VPLS):</i>	15.1F4	15.1F5
<ul style="list-style-type: none"> BGP multihoming for inter-AS VPLS Gigabit Ethernet as core-facing interface Configurable label block sizes Hashing L3/L4 fields under Ethernet pseudowire for VPLS encapsulation, CCC encapsulation, and MPLS encapsulation VPLS flood forwarding table filter (FTF), input FTF Broadcast, unicast unknown, and multicast (BUM) traffic hashing over LAG 		
Virtual private network (VPN)	15.1F4	15.1F5
<i>Virtual Router Redundancy Protocol (VRRP) for IPv4</i>	15.1F4	15.1F5
VPLS packet flooding to the right set of interfaces across mesh groups	15.1F4	15.1F5
WAN-PHY mode	-	-

Related Documentation

- [MPC7E \(Multi-Rate\) on page 182](#)
- [MPC7E 10G on page 185](#)

Protocols and Applications Supported by MPC8E and MPC9E on the MX2010 and MX2020 Routers

Table 76 on page 343 lists the protocols and applications supported by MPC8E and MPC9E on the MX2010 and MX2020 routers.

An en dash indicates that the protocol or application is not supported.

Table 81: Protocols and Applications Supported by MPC8E and MPC9E on the MX2010 and MX2020 Routers

Protocol or Application	First Supported Junos OS Release	
	MPC8E	MPC9E
<i>Access Node Control Protocol (ANCP)</i>	-	-
Accepts traffic destined for generic routing encapsulation (GRE) tunnels or Distance Vector Multicast Routing Protocol (DVMRP) (IP-in-IP) tunnels <ul style="list-style-type: none"> • <i>Dynamic</i> • <i>Manual</i> 	15.1F5	15.1F5
<i>Bidirectional Forwarding Detection protocol (BFD)</i>	15.1F5	15.1F5
<i>Border Gateway Protocol (BGP)</i>	15.1F5	15.1F5
Bridge protocol data units (BPDUs)	15.1F5	15.1F5
BGP/MPLS virtual private networks (VPNs)	15.1F5	15.1F5
Class of service (CoS): <ul style="list-style-type: none"> • Maintain CoS across internal tunnel interfaces • Packet rewrites • Behavior aggregate (BA) classification • BA classification based on 802.1p of payload for core-facing VPLS interfaces • BA DSCP classification of MPLS packets for L3VPN/VPLS LSI and MPLS interfaces • Rate-limit option for per-port queues • BA DSCP classification for VPLS/CCC family • Configurable .1p inheritance: push and swap from the hidden tag • Configurable shaping overhead for scheduling 	15.1F5	15.1F5

Table 81: Protocols and Applications Supported by MPC8E and MPC9E on the MX2010 and MX2020 Routers (*continued*)

Protocol or Application	First Supported Junos OS Release	
	MPC8E	MPC9E
Class of service (CoS) per port: <ul style="list-style-type: none"> • Eight queues per port • Excess-rate and excess-priority configurations at the queue level • Shaping at the port level • Shaping at the queue level • Scheduling of queues based on the weighted round-robin (WRR) per excess-priority class • Round-robin scheduling of the queues per priority class • Weighted random early detection (WRED) 	15.1F5	15.1F5
Class of service (CoS) per virtual LAN (VLAN): <ul style="list-style-type: none"> • Accounting, filtering, and policing • IEEE 802.1p rewrite • Classification • Tricolor marking 	15.1F5	15.1F5
Class of service (CoS) per Point-to-Point Protocol over Ethernet (PPPoE) or Dynamic Host Configuration Protocol (DHCP) subscriber interfaces: <ul style="list-style-type: none"> • Accounting, filtering, and policing • IEEE 802.1p rewrite • Classification • Excess-rate and excess-priority configuration at the queue level • Tricolor marking • Shaping at the queue level • Scheduling of queues based on weighted round-robin (WRR) per priority class • Weighted random early detection (WRED) 	-	-
<i>Distributed Denial-of-Service (DDoS) Protection</i>	15.1F5	15.1F5
<i>DVMRP and GRE support—access side and server side</i>	-	-
<i>Dynamic Power Management</i>	15.1F5	15.1F5
<i>Ethernet Ring Protection Switching with multiple G.8032 instances</i>	15.1F5	15.1F5
<i>Flexible Queuing Mode</i>	15.1F5	15.1F5
<i>IEEE 802.1ag Ethernet OAM Continuity Check protocol</i>	15.1F5	15.1F5
<i>IEEE 802.1ag Ethernet OAM Linktrace protocol</i>	15.1F5	15.1F5
<i>IEEE 802.1ag Ethernet OAM Loopback protocol</i>	15.1F5	15.1F5

Table 81: Protocols and Applications Supported by MPC8E and MPC9E on the MX2010 and MX2020 Routers (*continued*)

Protocol or Application	First Supported Junos OS Release	
	MPC8E	MPC9E
IEEE 802.1ag maintenance association intermediate point (MIP) support, continuity check message (CCM), stacked VLAN tagging, trunk ports, support for VPLS/VPWS, VLAN circuit cross-connect (CCC) encapsulation and translational cross-connect (TCC) encapsulation	15.1F5	15.1F5
IEEE 802.1ag optional type, length, and value (TLVs) support <i>Port Status TLV and Interface Status TLV</i>	-	-
IEEE 802.3ah distributed periodic packet management (PPM) process, alarm indication signal (AIS), and remote defect indication (RDI)	15.1F5	15.1F5
<i>Firewall filters and policers:</i>	15.1F5	15.1F5
<ul style="list-style-type: none"> • Policer support for aggregated Ethernet • Aggregate firewall-based policer for all families of a logical interface • Intelligent hierarchical policers • Set forwarding class and loss priority for Routing Engine-generated packets by using a firewall • Physical interface policers, applying policers to the entire port • Lower policer limit from 32,000 to 8000 • Egress .1p MF and BA classification for VPLS • Differentiated Services Code Point (DSCP) rewrite for IPv4 and IPv6 		
<i>Flexible Ethernet encapsulation</i>	15.1F5	15.1F5
<i>Graceful Routing Engine Switchover (GRES)</i>	15.1F5	15.1F5
IGMPv3 support with snooping disabled	15.1F5	15.1F5
Ingress and egress hierarchical class-of-service (CoS) shaping and <i>hierarchical-scheduler:</i>	15.1F5	15.1F5
<ul style="list-style-type: none"> • Set of Interfaces • VLAN level • Port level 		
<i>Inline flow monitoring</i>	15.1F5	15.1F5
<i>Intelligent Oversubscription</i>	15.1F5	15.1F5
<i>Integrated routing and bridging (IRB)</i>	15.1F5	15.1F5
Unified <i>In-service software upgrade (Unified ISSU)</i>	-	-
Interoperability with existing MPCs	15.1F5	15.1F5

Table 81: Protocols and Applications Supported by MPC8E and MPC9E on the MX2010 and MX2020 Routers (*continued*)

Protocol or Application	First Supported Junos OS Release	
	MPC8E	MPC9E
IPv4	15.1F5	15.1F5
<i>IPv4 multicast</i>	15.1F5	15.1F5
<i>IPv6</i>	15.1F5	15.1F5
IPv6 MLD	15.1F5	15.1F5
<i>IPv6 multicast</i>	15.1F5	15.1F5
<i>IPv6 Neighbor Discovery</i>	15.1F5	15.1F5
<i>IS-IS</i>	15.1F5	15.1F5
ITU-T Y.1731 timestamping support on MX Series routers	-	-
Flow monitoring and services:	Release	Release
<ul style="list-style-type: none"> Active monitoring (cflowed version 9 templates) Port mirroring family VPLS, bridge CCC encapsulation (VPWS) Packet slice for port mirroring Flow monitoring on MS-DPCs Inline flow monitoring on MPC8E and MPC9E 	<ul style="list-style-type: none"> 15.1F5 15.1F5 15.1F5 - 15.1F5 	<ul style="list-style-type: none"> 15.1F5 15.1F5 15.1F5 - 15.1F5
<i>Labeled-switched-paths (LSPs)</i> including accounting, policers, and filtering	15.1F5	15.1F5
<i>LDP</i>	15.1F5	15.1F5
Layer 2 features:	Release	Release
<ul style="list-style-type: none"> Trunk ports Layer 2 support for MX Series Virtual Chassis Layer 2 and Layer 2.5, IRB and spanning tree protocols (xSTP) IEEE 802.1ad provider bridges Layer 2 protocol tunneling (L2PT) support Layer 2 Tunneling Protocol (L2TP) Multichassis LAG—active/active and active/standby Multichassis LAG—active/active with IGMP snooping IGMP snooping with bridging, IRB, and VPLS 	<ul style="list-style-type: none"> 15.1F5 - 15.1F5 15.1F5 15.1F5 15.1F5 15.1F5 15.1F5 15.1F5 	<ul style="list-style-type: none"> 15.1F5 - 15.1F5 15.1F5 15.1F5 15.1F5 - - 15.1F5
Layer 2 VPN interfaces support VLAN ID list	15.1F5	15.1F5
<i>Link aggregation (IEEE 802.3ad)</i>	15.1F5	15.1F5

Table 81: Protocols and Applications Supported by MPC8E and MPC9E on the MX2010 and MX2020 Routers (*continued*)

Protocol or Application	First Supported Junos OS Release	
	MPC8E	MPC9E
<i>Link Aggregation Control Protocol (LACP)</i>	15.1F5	15.1F5
<i>Link Layer Discovery Protocol (LLDP)</i>	15.1F5	15.1F5
Local loopback	15.1F5	15.1F5
<i>MAC learning, policing, accounting, and filtering</i>	15.1F5	15.1F5
Mobile IP	-	-
Multichassis Link Aggregation	15.1F5	15.1F5
Multiple Tag Protocol Identifiers (TPIDs)	15.1F5	15.1F5
<i>MPLS:</i>	15.1F5	15.1F5
<ul style="list-style-type: none"> • Switching of pseudowire segments (multisegment pseudowires with BGP-L2VPN) • LDP signaling for VPLS (LDP-VPLS) and MAC flush message processing (MAC-FLUSH-TLV) • RSVP graceful restart interoperability with Cisco using Nodal Hello • Failure action on BFD session down of RSVP LSPs • OSPF and IS-IS loop-free alternates (LFA) • 4/5 label MPLS operation • Virtual circuit connectivity verification (VCCV) BFD • MPLS-FRR bypass link protection • Load sharing across 64 ECMP next hops • MPLS-FRR VPLS instance prioritization • Five label stack on ingress 		
MPLS node protection, link protection, and statistics for static LSPs	15.1F5	15.1F5
<i>Multiple VLAN Registration Protocol (MVRP)</i>	-	-
<i>Multitopology routing</i>	15.1F5	15.1F5
Nonstop active routing (NSR)	15.1F5	15.1F5
<i>OSPF</i>	15.1F5	15.1F5
Packet mirroring	15.1F5	15.1F5
Precision Time Protocol (IEEE 1588)	-	-
IEEE 802.1ah provider backbone bridging (PBB)	-	-

Table 81: Protocols and Applications Supported by MPC8E and MPC9E on the MX2010 and MX2020 Routers (*continued*)

Protocol or Application	First Supported Junos OS Release	
	MPC8E	MPC9E
<i>RSVP</i>	15.1F5	15.1F5
<i>RIP</i>	15.1F5	15.1F5
<i>SNMP</i>	15.1F5	15.1F5
Spanning tree protocols:	15.1F5	15.1F5
<ul style="list-style-type: none"> • <i>IEEE 802.1s Multiple Spanning Tree Protocol (MSTP)</i> (part of IEEE 802.1Q VLANs) • <i>IEEE 802.1w Rapid Spanning Tree Protocol (RSTP)</i> • <i>IEEE 802.1D Spanning Tree Protocol (STP)</i> • Per-VLAN Spanning Tree (PVST) • Bridge protocol data units (BPDUs) guard and loop guard • STP inter-protocol action profiles and MAC flush (in VPLS multi-homing, flush all MACs when there is a change in the STP interface state due to root protect) 		
<i>Subscriber management and services:</i>	-	-
(MX2010, MX2020: 12.3R4, 13.2R2, 13.3)		
<ul style="list-style-type: none"> • Aggregated Ethernet over static VLANs • Aggregated Ethernet over dynamic VLANs • <i>Access Node Control Protocol (ANCP) and the ANCP Agent</i> • DHCP access model • Dynamic adjustment of shapers • Dynamic PPPoE subscriber interface creation based on PPPoE service name table configuration • Dynamic profiles • Dynamic shaping, scheduling, and queuing • Dynamic VLANs • Per unit scheduling • Static and dynamic PPPoE subscriber interfaces 		
Synchronous Ethernet	16.1R1	16.1R1
<i>Two-Way Active Measurement Protocol (TWAMP)</i>	-	-
Tunnel services	15.1F5	15.1F5
Unified in-service software upgrade (ISSU)	-	-
Unnumbered Ethernet Interface	15.1F5	15.1F5

Table 81: Protocols and Applications Supported by MPC8E and MPC9E on the MX2010 and MX2020 Routers (*continued*)

Protocol or Application	First Supported Junos OS Release	
	MPC8E	MPC9E
VLANs <i>IEEE 802.1Q</i> : <ul style="list-style-type: none"> • VLAN stacking and rewriting • Channels defined by two stacked VLAN tags • Flexible VLAN tagging • IP service for nonstandard TPID and stacked VLAN tags 	15.1F5	15.1F5
Virtual Chassis: MPLS IPv4 and IPv6, unicast, multicast forwarding, VPLS, NSR for Layer 3/MPLS services	-	-
Virtual private LAN service (<i>VPLS</i>): <ul style="list-style-type: none"> • BGP multihoming for inter-AS VPLS • Gigabit Ethernet as core-facing interface • Configurable label block sizes • Hashing L3/L4 fields under Ethernet pseudowire for VPLS encapsulation, CCC encapsulation, and MPLS encapsulation • VPLS flood forwarding table filter (FTF), input FTF • Broadcast, unicast unknown, and multicast (BUM) traffic hashing over LAG 	15.1F5	15.1F5
Virtual private network (VPN)	15.1F5	15.1F5
Virtual Router Redundancy Protocol (<i>VRRP</i>) for IPv4	15.1F5	15.1F5
VPLS packet flooding to the right set of interfaces across mesh groups	-	-

- Related Documentation**
- [MPC8E on MX Series Routers Overview](#)
 - [MPC9E on MX Series Routers Overview](#)

Protocols and Applications Supported by the MS-MIC and MS-MPC

Table 82 on page 388 contains the first Junos OS Release support for protocols and applications on the MX104, MX240, MX480, and MX960 Multiservices MIC (MS-MIC) and Multiservices MPC (MS-MPC). A dash indicates that the protocol or application is not supported.



NOTE: Multiservices MPC is not supported on MX104 routers.

Table 82: Protocols and Applications Supported by the MS-MIC and MS-MPC

Software Feature	First Supported Junos OS Release
GRE Key	–
GRE dont-fragment	–
Stateful firewall	13.2R4
Network Address Translation (NAT) for IP addresses	13.2R4
Port Address Translation (PAT) for port numbers	13.2R4
IP Security (IPSec) encryption	13.2R4
Flow aggregation	–
Active flow monitoring exports cflowd version 5 and version 8 records	–
Active flow monitoring exports flow monitoring version 9 records, based on RFC 3954	13.2R4
<i>Graceful Routing Engine Switchover (GRES)</i>	13.3 <i>NOTE: GRES is not supported for MS-MIC on MX104 router.</i>
Passive flow monitoring	–
Passive flow collection	–
Flow-tap	–
Dynamic flow capture	–
Real-time performance monitoring	13.3
Link Services	–
MX Series Virtual Chassis with stateful firewall	14.2
Traffic sampling	13.2R4
Tunnel services: <ul style="list-style-type: none"> • IP-IP unicast tunneling • GRE unicast tunneling—Supports GRE fragmentation • Protocol Independent Multicast (PIM) sparse mode unicast tunneling 	–
Virtual tunnel interface for Layer 3 VPNs	–

Table 82: Protocols and Applications Supported by the MS-MIC and MS-MPC (*continued*)

Software Feature	First Supported Junos OS Release
Layer 2 Tunneling Protocol (L2TP)	–
Voice services:	–
<ul style="list-style-type: none"> Compressed Real-Time Transport Protocol (CRTP) 	
Encapsulations:	–
<ul style="list-style-type: none"> Multilink Frame Relay (MLFR) Multilink Point-to-Point Protocol (MLPP) 	

- Related Documentation**
- [MX Series MPC Overview on page 11](#)
 - [MPCs Supported by MX240, MX480, MX960, MX2010, and MX2020 Routers on page 12](#)
 - [Multiservices MIC on page 253](#)
 - [Multiservices MPC on page 136](#)

